

THEORY OF COMPLEMENTATION IN ENGLISH SYNTAX

by

JOAN WANDA BRESNAN

B.A., Reed College
(1966)

SUBMITTED IN PARTIAL FULFILLMENT
OF THE REQUIREMENTS FOR THE
DEGREE OF DOCTOR OF
PHILOSOPHY

at the

MASSACHUSETTS INSTITUTE OF
TECHNOLOGY

September 1972

Signature of Author
Department of Foreign Literatures and
Linguistics, August 14, 1972

Certified by
Thesis Supervisor

Accepted by
Chairman, Departmental Committee on
Graduate Students

Hum.



THEORY OF COMPLEMENTATION IN ENGLISH SYNTAX

by

Joan W. Bresnan

Submitted to the Department of Foreign Literatures and Linguistics on August 14, 1972, in partial fulfillment of the requirements for the degree of Doctor of Philosophy.

ABSTRACT

The subject of this study is the role of the complementizer in English syntax and its implications for syntactic theory. It is argued that the familiar transformational treatment of complementizers is inadequate, and that they must be specified in deep structure by means of a Phrase Structure rule. The WH, or Q, morpheme is related systematically to that and for. Semantic functions of these three clause-initial morphemes are isolated, and applications are made to relative clause complementizers. A syntactic analysis of infinitival S complements is given: first it is shown how complementizers restrict the movement of subjects in English (the Fixed Subject Constraint), and then the "nominative and infinitive" and "accusative and infinitive" constructions are analyzed in relation to subject-moving rules. The conclusion, that not all infinitival S complements derive from for complements, buttresses the semantic analysis of for, which required this assumption. The question of how complementizers are to be represented syntactically is then returned to, and a justification is made for a syntactic level of deep structure distinct from "logical structure". Finally, the inventory of complementizers is extended to the comparative complementizers than and as, which are parallel to the relative clause complementizers. A fairly detailed analysis of the comparative clause construction is given, and in the light of new facts, the Fixed Subject Constraint is revised.

Thesis Supervisor: Noam Chomsky

Title: Ferrari P. Ward Professor of Modern Languages and Linguistics

ACKNOWLEDGMENTS

It is hard to express adequate thanks to Noam Chomsky and Morris Halle, teachers who have created a field and encouraged their students' independence in it. Both of them have helped me in many particulars with this thesis, but my larger debt to them as a student outweighs this. I would also like to give special thanks to Haj Ross, who has made generous and detailed criticisms of most of the manuscript. Certain people were enormously helpful to me in developing my ideas on various topics: Joe Emonds (Ch.1), Howard Lasnik (Ch.3), Will Leben (Ch.4), David Vetter and Lisa Selkirk (Ch.5). I am also grateful to David Perlmutter, Ken Hale, Paul Kiparsky, Kinsuke Hasegawa, Rudolph de Rijk, and Mike Brame for help on particular problems.

Thanks to Morris Halle, I had the opportunity of teaching much of the material of this thesis in a seminar in advanced syntax at MIT. Many improvements came out of the discussion and criticism by those who attended, especially Roger Higgins, Jorge Hankamer, Emily Pope, Wayles Browne, Bob Faraci, Edwin Williams, and Tom Wasow.

Susan Wolf has been an invaluable source of linguistic and other intuitions.

TABLE OF CONTENTS

| | |
|---|-----|
| INTRODUCTORY NOTE | 6 |
| CHAPTER 1: ON COMPLEMENTIZERS | 9 |
| A) The Transformational Hypothesis of Complementizer Insertion | 9 |
| B) The Syntactic Inadequacy of the Transformational Hypothesis | 16 |
| C) The System of Complementizers WH, <u>that</u> , and <u>for</u> | 28 |
| FOOTNOTES TO CHAPTER 1 | 48 |
| CHAPTER 2: THE SEMANTIC FUNCTIONS OF THE PREDICATE COMPLEMENTIZERS | 60 |
| FOOTNOTES TO CHAPTER 2 | 92 |
| CHAPTER 3: THE ROLE OF THE COMPLEMENTIZER IN INFINITIVAL COMPLEMENTATION | 95 |
| A) The Fixed Subject Constraint | 95 |
| B) The Source of the Shifting Subject | 117 |
| (i) The Problem | 117 |
| (ii) A Solution | 124 |
| (iii) Relation to the Passive | 137 |
| C) The Accusative and Infinitive | 149 |
| (i) The Problem: Two Paradigms | 153 |
| (ii) Previous Analyses | 165 |
| (iii) A Possible Solution | 170 |

| | |
|---|-----|
| (iv) Problems with the Solution: Is There a Subject Raising Transformation? | 177 |
| FOOTNOTES TO CHAPTER 3 | 185 |
| CHAPTER 4: ON THE NATURE OF SYNTACTIC REPRESENTATION | 191 |
| A) Transformation vs. Phrase Structure Rules | 191 |
| B) The Elimination of Deep Structure and the Growth of Syntactic Irregularity | 195 |
| C) Complementizers and Deep Structure . | 200 |
| D) On the Syntactic Representation of Comparatives | 207 |
| FOOTNOTES TO CHAPTER 4 | 218 |
| CHAPTER 5: EXTENDING THE INVENTORY OF COMPLEMENTIZERS | 219 |
| A) Introduction | 219 |
| B) On Comparatives | 229 |
| (1) Syntax of the Head | 229 |
| (11) Comparative Formation | 282 |
| (111) The Fixed Subject Constraint Revisited | 305 |
| FOOTNOTES TO CHAPTER 5 | 309 |
| LIST OF REFERENCES | 315 |
| BIOGRAPHICAL NOTE | 321 |

INTRODUCTORY NOTE

"Complementizer", like so many terms in linguistics, is a rebarbative word. A natural suspicion attaches to objects going by such a name. Unlike such weighty and venerable things as predicates, quantifiers, sentences, and even conjunctions, the so-called "complementizers" lack ready associations with logic. But therein, perhaps, lies their special interest to the syntactician. What are complementizers? What are they for? These clause-particles are to be found in each of the major subsystems of English syntax -- in predicate complementation, comparative clause constructions, and relative clause constructions. What are they doing there?

I must confess at once that I cannot answer these questions: without detailed and careful research into many languages, one cannot begin to define "complementizer" in an adequate way. But while I do not attempt to define "complementizer", I try to show that those conjunctive particles of English which I call complementizers are a subject of interest, and perhaps even a syntactic category.

I take the English complementizers to be those S-initial morphemes which distinguish clause types: they include that, for, than, as, and WH, or "Q". The main results I

try to establish for the English complementizers are these:

- 1) They must be specified at the level of deep structure in a position determined by a Phrase Structure Rule (chapters 1, 4).
- 2) They have distinct semantic functions (chapter 2).
- 3) In English, but not in all languages, complementizers affect the application of movement rules to subjects (chapters 3, 5).
- 4) English has an infinitival S complement unmediated by a complementizer (chapter 3).
- 5) The conjunctive particles introducing comparative and relative clauses belong in the inventory of English complementizers (chapter 5).

To establish these results, I look into several subsystems of English syntax -- the "predicate complement" system (chapters 1-3) and the "determiner complement" system of comparative and relative clause constructions (chapters 4 and 5). My analyses are by no means exhaustive or complete accounts of these syntactic subsystems, but are instead selective explorations of some of the grammatical regions where complementizers occur or have been thought to occur. Two particularly obvious defects are my complete disregard of the so-called Poss-ing complementizer and my invidious neglect of the relative clause in favor of a fairly detailed analysis of the comparative. This im-

balance could only be rectified by an extended treatment of the internal structure of the noun phrase, including articles and quantifiers -- matter for separate monographs.

CHAPTER 1
ON COMPLEMENTIZERS

A) The Transformational Hypothesis of Complementizer Insertion

In virtually all analyses of complementation within the framework of generative grammar the following sentences would differ only by optional transformations in derivations from a common deep structure:

- 1) It may distress John for Mary to see his relatives.
- 2) It may distress John that Mary sees his relatives.
- 3) Mary's seeing his relatives may distress John.

The particles that, for - to, 's-ing -- the so-called "complementizers" -- have been viewed as markers of syntactic subordination having neither semantic content nor significant syntactic function. Accordingly, examples (1) - (3) have usually been assigned a common underlying structure roughly similar to that represented in (4):¹

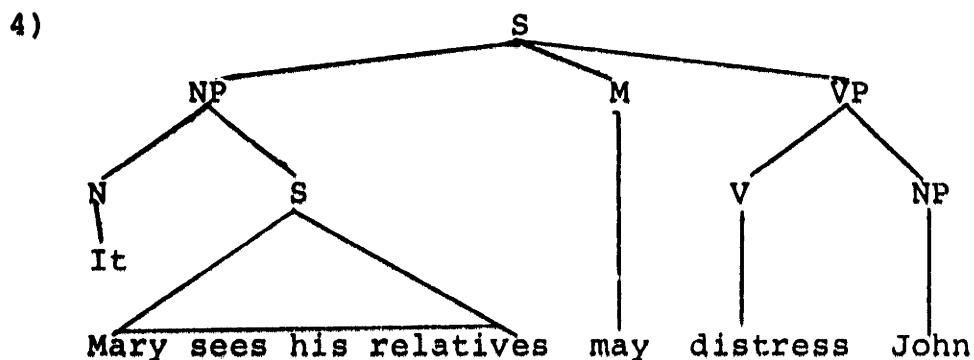

In the derivation of (1) - (3) from (4), one or more transformations have been held to insert a complementizer into the embedded sentence. This theory of complement types I will call the "transformational hypothesis". The transformational hypothesis entails that sentential complement types (that-, for-to-, and 's-ing- clauses) are not distinguishable in deep structure.

Since it is clear that not all verbs taking complements can occur with every complementizer --

- 5) They implied that their children were happy.
 *They managed that their children were happy.
- *They implied for their children to be happy.
 They managed for their children to be happy.
- *They implied their children's being happy.
 ?They managed their children's being happy.

-- it is evident that some characteristic of the higher verb or predicate affects the choice of complementizers. Given the transformational hypothesis, one possible assumption is that a "rule feature" (Lakoff 1971) is associated with verbs and predicates; thus if the transformation introducing for-to is called R, then (judging from (2) and (5)) the verbs distress, imply, manage would be marked in the lexicon (either directly or by a redundancy rule) as [+R], [-R], respectively.

Because the complementizer-insertion transformations have to be sensitive to the rule feature on the higher verb,

there is a peculiarity in their operation: they cannot insert complementizers into a sentence S during the transformational cycle on S, but only during the cycle on the next sentence dominating S.

To illustrate this feature of the transformational hypothesis, diagram (6) shows in a simplified way several steps in the derivation of (2); the S being cycled (see Chomsky (1965) on the notion of transformational cycle) is indicated by a circle:

6) a.

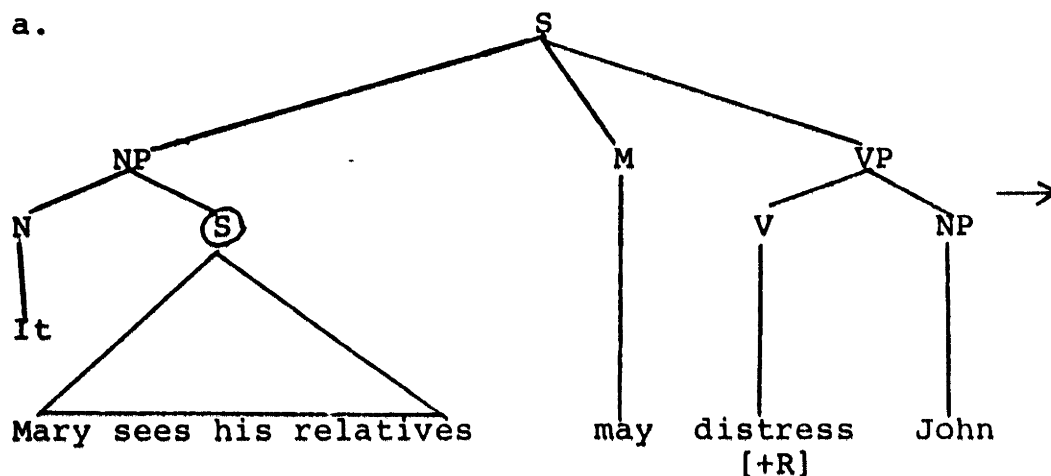

b.

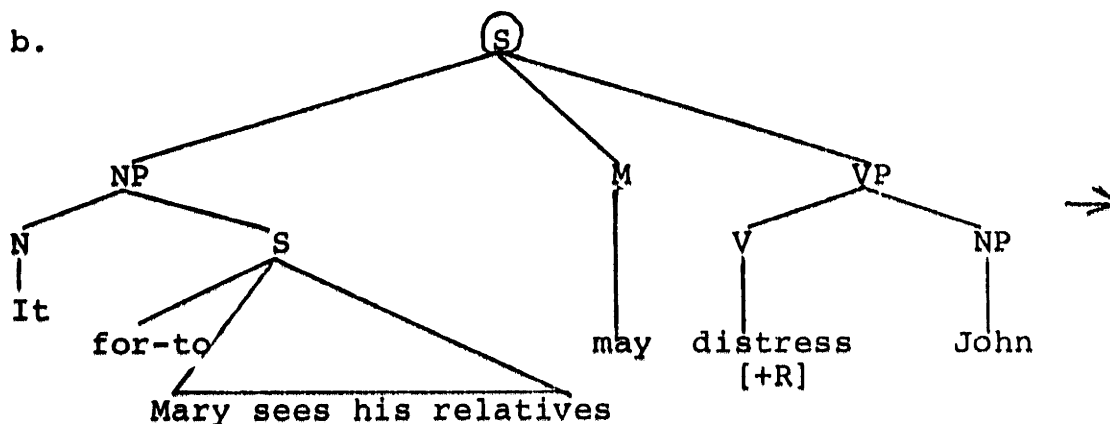

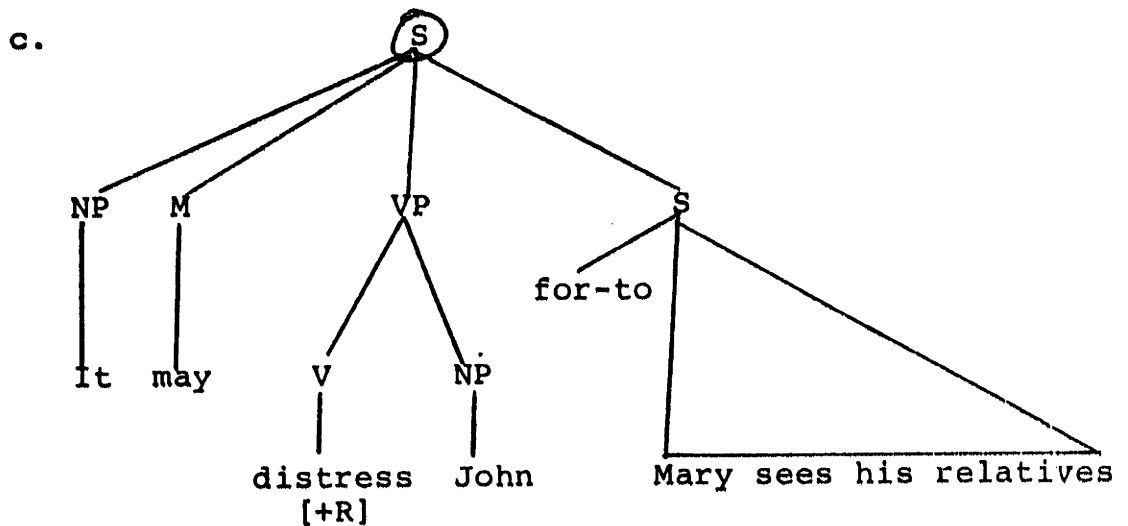

On the first cycle (6a) no transformations apply. If a transformation, say the passive, were to apply on this cycle, then ultimately the sentence It may distress John for his relatives to be seen by Mary would result. On the second cycle (6b-c) the transformation inserting for-to (rule R) applies, because distress is marked [+R]. Finally, another transformation shifts the for-to complement to the end. The key point is that complementizer insertion could not occur on the first cycle because the transformation would not "know" which complementizers are permitted by the verb distress until the next cycle. In other words, the structural description of any complementizer-insertion transformation cannot be limited to a complement clause, but must include the verb or adjective which that clause complements.

This peculiarity guarantees that nonembedded sentences will never appear with complementizers --

7) *That they imagined it.

-- but at the same time it violates a general condition on transformations stated by Chomsky (1965:146), namely that while transformations may remove material from embedded sentences, no transformation can insert morphological material into "lower" sentences.²

Let us now consider an alternative theory -- the "phrase-structure hypotheses" -- which I shall justify in this study. According to the phrase-structure hypothesis, complementizers are specified in deep structure by means of a phrase-structure rule. The rule for English would look like

8) $\bar{S} \rightarrow \text{COMP } S$

Where the symbol COMP represents a deep structure node (or feature bundle (Chomsky 1971b)) which dominates (or is featurally specified for) complementizers. As I will show, the underlying predicate complementizers of English are that, WH ("Q"), and for.³ There is evidence from syntax, semantics, and universal grammar that complementizers are far from the semantically empty, syntactically trivial particles they have been assumed to be in most previous generative work.

As an illustration of the phrase structure hypotheses, note that (1) - (3) would have different underlying

structures: (2), for example, would be represented as⁴

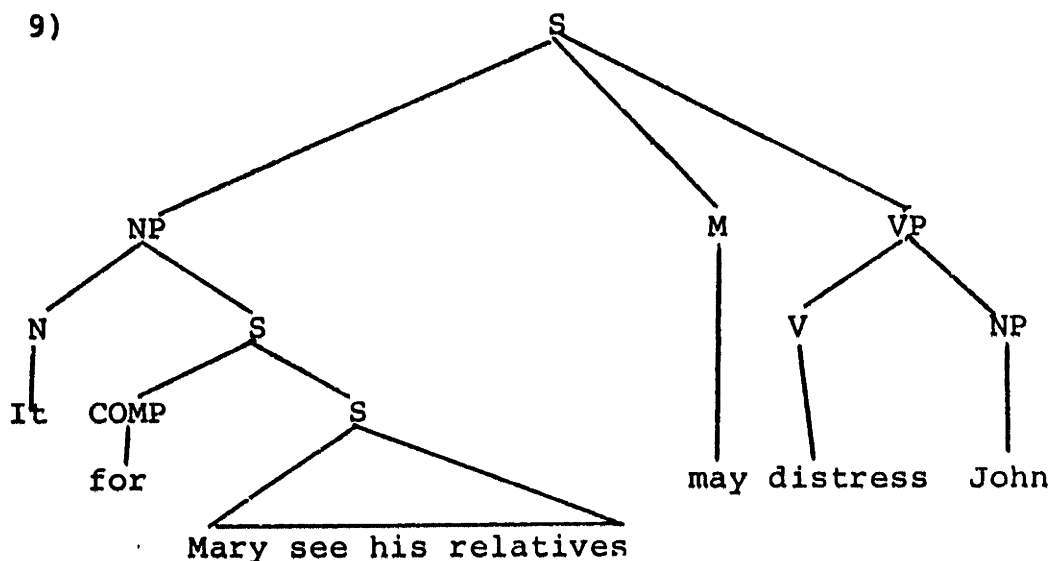

Notice that the rule-feature [+R] is unnecessary: since complementizers are specified in deep structure, verbs could be subcategorized for the type of complement they take. Thus because distress permits object NP's together with subject for-complements, it may be inserted from the lexicon into the deep structure (9) as shown.⁵ This means of associating complement-types with lexical items is in accord with recent work which has suggested that the device of rule features may be less appropriate than subcategorization as a means of describing many kinds of grammatical phenomena (Kayne 1969a; Emonds 1970; see also Chapters 3 and 4 of this work).

The presence of complementizers in deep structure opens up a further possibility: these "conjunctive particles" may themselves be meaning-bearing. Indeed, there is already evidence that for some classes of verbs, meaning differences

are associated with complementizer choice (Kiparsky and Kiparsky 1971; Bolinger 1968; Anscombe 1967). If the predicate complementizers have distinct semantic functions, then the compatibility of predicate with complement type might depend on meaning. In Chapter 2 I show that WH, that, and for actually have distinct semantic functions which partially determine the kinds of predicates typically associated with these complementizers.

Besides the erroneous view that complementizers are semantically empty, the only other argument I know of in favor of the transformational hypothesis is an ingenious one by George Lakoff (related in Kajita (1967:113)).

Consider the following examples:

10) John wanted to be a concert pianist, but his father talked him out of it.

11) John wanted it [_SFuture for John to be a concert pianist] but his father talked him out of it
 [_SFuture John's being a concert pianist]

If (10) is derived from (11) by a rule deleting the rightmost S under identity with the leftmost, the presence of different complementizers in deep structure would make the two S's nonidentical. Given the general condition on recoverability of deletions (Katz and Postal 1964:79-81; Chomsky 1965:144-47), the fact that deletion does appear to take place suggests that the two S's are identical in deep structure, and hence that complementizers are not present

there.

Recent work has shown that there is evidence against such a S-deletion rule (Akmajian 1968; Chomsky 1971; Bresnan 1971). However, even if such a rule could be motivated, it would not provide evidence against the phrase structure hypothesis sketched above, for a deep structure like

12) John wanted it [_S COMP S], but his father talked
him out of it [_S COMP S]

would permit S-deletion to operate as usual (on the "inner" S) and a later rule would delete dangling complementizers.

B) The Syntactic Inadequacy of the Transformational Hypothesis

In this section I give two basic arguments showing that the distribution of the complementizers that and for cannot be correctly described under the transformational hypothesis, but can be under the phrase structure hypothesis. The first argument is that the choice of complementizer does not merely depend upon the main verb, as the transformational hypothesis leads us to expect, but is a function of the presence of modals, other complementizers, and the type of subject or object subcategorized by the verb. The syntactic factors conditioning complementizer choice are more characteristic of subcategorization rules than

syntactic transformations. The second argument is based on the interaction of a putative complementizer-insertion transformation with other transformations.

To see that complementizers appear to subcategorize verbs, consider such verbs as mean, show, imply, reveal, entail, suggest, prove, which take multiple sentential complements:

- 13) That he eats cabbage means nothing.
- 14) This means that he is of low birth.
- 15) That he eats cabbage means that he is of low birth.

The that-complement can occur as both subject and object, but the for-complement cannot:

- 16) For him to eat cabbage means nothing.
= It means nothing for him to eat cabbage.
- 17) *This means for him to eat cabbage.⁶

If COMP were not in deep structure, these facts could not be described by known transformational means, including rule features; for if there were a complementizer-insertion transformation operant in (13) - (17), it would have to be sensitive not only to the rule feature in the verb, but to the subcategorization of the verb -- that goes on subject or object, for on subject only. The device of annotating the lexical entry for mean with a feature [+R] is simply inadequate.

There is another problem: sentences like the following are

ungrammatical:

- 18) *For him to eat cabbage means that he will be sick.

Apparently, then, there are interdependencies between complements which affect the choice of complementizer: when that occurs in the object, for cannot occur in the subject.

However, if a suitable modal is added to a sentence like (18), it becomes perfectly acceptable:

- 19) In those days, for him to eat cabbage would have meant that he was of low birth.

In this case, a that complement in subject position has a quite different meaning:

- 20) In those days, that he ate cabbage would have meant that he was of low birth (but for the fact that...).

Thus, a complementizer-insertion transformation would have to refer not only to the verb and its strict subcategorization features, but also to the modal auxiliary. (Examples like (18) - (20) are discussed further in Chapter 2.)

In fact there are even cases where the choice of complementizer in subject position depends upon the choice of complementizer in object position: on the transformational hypothesis the facts are unstatable, since both complementizers must be inserted in the same cycle. Take, for example, the verb indicate, which can have sentential

objects prefixed by that or WH:

21) That would have indicated whether or not she was a witch.

22) That would have indicated that she was a witch.

The choice of that or WH in the subject depends on the complement type of the object:

23) Whether she can drink this poison or not will indicate { that whether or not } she is a witch.

24) That she can drink this poison indicates { that *whether or not } she is a witch.

Now observe that the presence of for in the subject requires a that-object:

25) For her to have known chemistry would have indicated { that *whether or not } she was a witch.

A that-complement is possible in the same context as for, but has a different meaning:

26) That she knew chemistry would have indicated { that *whether or not } she was a witch (if she hadn't died during the poison test).

This web of interdependencies cannot even be described within the standard rule-government framework.

On the other hand, it is characteristic of subcategorization to display such interdependencies; for example, certain verbs prohibit noun phrase objects when they have

sentential subjects:

- 27) That John eats cabbage implies that he likes cabbage.
- 28) The first statement implies the second statement.
- 29) The first statement implies that the second statement is true.
- 30) *That the first statement is true implies the second statement.

Further evidence that verbs are more naturally subcategorized for complementizers than marked with rule features for a complementizer-insertion transformation appears in the case of tell. For tell the choice of complementizer depends upon the presence of another object of the verb. Consider, for example,

- 31) Susie didn't tell $\left\{ \begin{array}{l} *that \text{ they had eaten} \\ \text{whether they had eaten} \end{array} \right\}$.
- 32) Susie didn't tell us $\left\{ \begin{array}{l} that \text{ they had eaten} \\ \text{whether they had eaten} \end{array} \right\}$.

These examples suggest that that is permitted with tell only if the indirect object is specified in deep structure. To be more explicit: there is evidence that tell always has objects in deep structure, for totally intransitive verbs may occur where tell cannot, as in the sleeping man vs. *the telling man.⁷ This evidence presents at least two possibilities for explaining (31) and (32). The first possibility (Chomsky 1964) is that the relevant

object of tell can be deleted when it is a "designated element," such as someone. In this case, the deletion rule might be made sensitive to the type of complement in a way that could describe (31) and (32) without recourse to subcategorization. But the presence of the additional morphological material in tell someone vs. tell has semantic consequences which argue against this alternative: note the difference between

33) I always like to tell stories -- but not necessarily to anyone. (Often I just spin a yarn for my own benefit.)

and

34) *I always like to tell stories to someone -- but not necessarily to anyone.

-- which is overtly contradictory.

The second possibility (Chomsky 1964) is that the indirect object of verbs like tell may occasionally be a dummy element -- that is, may occasionally fail to be filled by lexical insertion rules. This alternative, which seems to be semantically preferable, is the one which I am assuming in my discussion of (31) and (32), and it may well be preferable in general. Since the option of having such dummy objects is restricted to certain lexical items only (for example, she ate, but not *it frightened), it is a matter of subcategorization; it follows that the choice of that with tell depends upon subcategorization.

The cases of tell and those verbs having multiple sentential complements provide intractable problems for the transformational hypothesis, but can be correctly described by means of subcategorization. The second basic argument establishing that complement types must be specified in deep structure appears upon examining the interactions of transformations with complementizers.

One transformation which bears on complementizer-insertion is Conjunction Reduction. Roughly speaking, this rule relates (35) to (36):

35) Both Jack and Jill were pushovers.

36) Jack was a pushover and Jill was a pushover.

Note that Conjunction Reduction is cyclic: it must precede on each cycle the cyclic transformation of There-Insertion and number agreement to obtain sentences like There were both a man and a woman in the car and There were believed to have been both a man and a woman in the car.⁸

The argument to follow has this form: were complementizers not distinguished in deep structure, but rather inserted by transformational rule, certain grammatical conjoined sentences would be underivable; but if complementizers are in deep structure these sentences are easily derivable from familiar rules. So temporarily I will assume that the transformational hypothesis is correct and that there

is a transformational rule of Complementizer Insertion; Given that Conjunction Reduction is cyclic, the only additional assumption needed is that Complementizer Insertion is not precyclic, that is, does not precede the entire transformational cycle. This is not implausible, because there are no fully persuasive examples of precyclic transformations.⁹

The interaction of Complementizer Insertion and Conjunction Reduction depends primarily upon the tree configuration to which they apply.

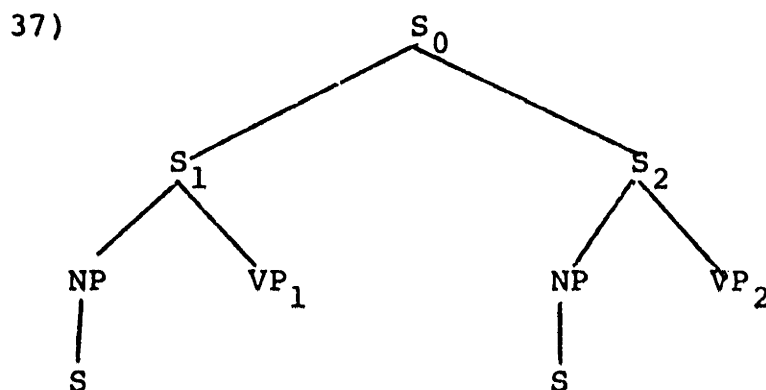

In a structure like (37) the earliest point at which Complementizer Insertion could apply (under any ordering hypothesis) is at S_1 (or S_2), since it must be governed by the V in VP_1 (or VP_2); Conjunction Reduction -- by virtue of its structural description -- cannot apply before the S_0 cycle.

On the other hand, there are cases where Conjunction Reduction would have to precede Complementizer Insertion in the derivation, as in (38) (or any other configuration

containing conjoined S nodes at a greater level of embedding than the governing VP):

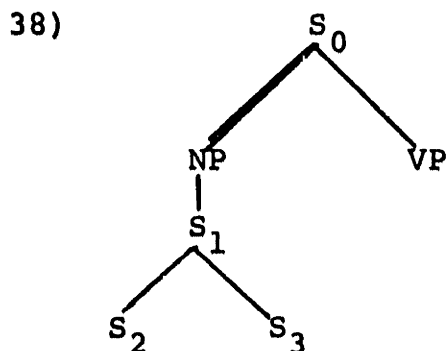

Here the structural description of Conjunction Reduction is met at S_1 , but the structural description of Complementizer Insertion cannot be met until S_0 . Hence, in a case like (38), Conjunction Reduction will necessarily precede Complementizer Insertion in the derivation.¹⁰

I shall now show that there are sentences which must be derived from structures which are like (38) in the relevant respects, and that complementizers must be present on S_2 and S_3 before Conjunction Reduction applies on S_1 and hence before Complementizer Insertion could have applied. This evidence crucially distinguishes between the transformational hypothesis and the phrase structure hypothesis.

To see that structures like (38) must be generated directly, consider the sentence

39) It is strange that Kip flew to New York and
that Mary flew to Chicago.

(39) is actually ambiguous: on one reading it asserts

the strangeness of a conjunction of events; but on another reading it conjoins assertions of strangeness. The latter reading of (39) is illustrated in the following discourse, where speaker B is contradicting speaker A:

A: It is strange that Kip flew to New York, but
I'm not surprised that Mary flew to Chicago.

B: It is strange that Kip flew to New York and that
Mary flew to Chicago.

B's statement is paraphrasable by (40):

40) It is strange both that Kip flew to New York and
that Mary flew to Chicago.

(40) and, under this reading, (39), may be derived from structure (37) by Conjunction Reduction; that is, they may be derived from the structure underlying (41)

41) It is strange that Kip flew to New York and
it is strange that Mary flew to Chicago.

-- which is understood as conjoining assertions of strangeness. But the other reading of (39) -- the assertion that a conjunction of events is strange -- is not so derivable; under this reading (39) lacks the high pitch on and which is characteristic of sentences having undergone Conjunction Reduction. Here, then, is an example of a sentence which must be directly generable as (38).

Now I will show that complementizers must be present before Conjunction Reduction applies to structures like (38),

and hence before Complementizer Insertion could have applied. Consider two sentences derived from structures like (38) (asserting that a conjunction of events is strange):

- 42) That Kip and that Mary both flew to New York
is strange.
- 43) For Kip and for Mary both to fly to New York
would be unusual.

After Conjunction Reduction has applied to (38) on the S_1 cycle, a derived structure roughly like (44) is produced; both (38) and (44) occur in the derivation of (42) and (43):

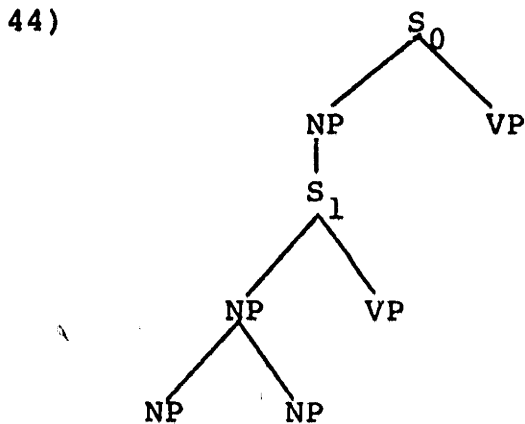

But there is no way for Complementizer Insertion to produce (42) and (43) from this structure. For let Complementizer Insertion apply to (44) and suppose there to be a later rule that optionally distributes a complementizer preceding a coordinate structure over the conjoined NP's. Any such solution would fail: from

- 45 a. I prefer that a man and his wife $\left\{ \begin{array}{l} \text{be similar.} \\ \text{resemble each} \\ \text{other.} \end{array} \right.$

- b. I prefer for a man and his wife to {be similar.
resemble each other.}

would come

- 46) a. *I prefer that a man and that his wife
{be similar.
resemble each other.}
- b. *I prefer for a man and for his wife to
{be similar.
resemble each other.}

These examples contain reciprocal or symmetric predicates, which cannot be derived from Conjunction Reduction: so, for example, (45a,b) could not come from

- 47) a. *I prefer that a man be similar and that his wife be similar.
- b. *I prefer for a man to be similar and for his wife to be similar.

Thus the ad hoc complementizer distribution rule would have to apply in just those cases where Conjunction Reduction has applied, though after the application of that rule such cases are presumably structurally indistinguishable from nonreduced cases of NP conjunction. (The existence of such is shown in Lakoff and Peters (1966) and Dougherty (1968).)

The above "solution" and others like it are merely means of approximating by transformation the natural behavior of deep structure complementizers under Conjunction Reduction: if the complementizers in (42) and (43) are present before Conjunction Reduction, their derivation is an automatic (though optional) consequence of that rule, exactly as in

- 48) He participates both in intra- and in extra-mural sports.
- 49) We need some left-handed and some right-handed pitchers on this team.

For some speakers, repetition is avoided in reduced structures and so (42) and (43) may sound somewhat less acceptable than (39); this is irrelevant to the question of complementizers, since for such speakers, (48) and (49) are presumably also marginal. The main point of this argument is that on the phrase structure hypothesis, sentences like (42) and (43) are derivable exactly as (48) and (49) are; while on the transformational hypothesis there is no way at all to derive (42 and (43)).¹¹

In summary, the syntactic distribution of that and for cannot be correctly described under the transformational hypothesis of complementizer insertion; and the phrase structure hypothesis must be preferred on grounds of descriptive adequacy.

C) The System of Complementizers WH, that, and for

The transformational hypothesis of complementizer insertion, sketched in section (A), has turned out to be syntactically inadequate on purely descriptive grounds: it does not

correctly describe the distributions of that and for, which appear to depend on subcategorization, modality, and even the choice of other complementizers; nor can it correctly describe their distribution in reduced coordinate structures. On the phrase structure hypothesis, by contrast, complementizers are available in deep structure for subcategorization and semantic interpretation, and their behavior under conjunction reduction is predictable. In this section I will argue that interrogative Q, which I call WH, belongs in the system of English complementizers: WH, that, and for behave like members of a single category introduced by a phrase structure rule $\bar{S} \rightarrow \text{COMP } S$.¹²

For a long time English lacked for as a complementizer. At one stage the predicate complementizers appeared to form a binary system of "marked" (WH) and "unmarked" (that): that occurred both with and without WH, and appeared to function primarily as a syntactic marker of subordination.¹³ As the preposition for evolved into a complementizer and was finally admitted into the system (Jespersen MEG V: pp. 308ff), there came into existence a three-way distinction between WH, for, and that. It may be conjectured that it was as a result of the entrance of for that that came to be a complementizer in its own right and ceased to cooccur with WH. At any rate, it is evident that English now has a trinary system of predicate complementizers which are mutually exclusive. This indeed is a salient fact expressed

by the phrase structure hypothesis, but not by the transformational hypothesis, as we shall now see.

(i)

It is striking that only one member of the set {that, for, WH} can occur in a clause (or S). Just as that and for are mutually exclusive --

50) *Marie asked that for us to leave her alone.

51) *For that he refuses would not be surprising.

-- so that, for, and WH are all mutually exclusive:

52) *I know that whether he came.

53) *For whom to own a rifle doesn't affect me.

54) *It doesn't matter to them whether that you march.

55) *I asked what for John to do.

On the transformational hypothesis, (52-55) might be avoided by adding prohibitions against placing complementizers in or on "Q" clauses, and (50, 51) might be avoided in some other way. But only if WH is recognized as a member of the system of complementizers can these facts (50-55) be related and explained. There is an analogy between the complementizers and the system of modal auxiliaries in English: the fact that the modals are mutually exclusive (*She may should can leave now) follows from their membership in a single category, distinct from verbs.

It would not affect this synchronic analysis if historically the English modals were true verbs and could cooccur; just as little does it affect our hypothesis if ME had a different, complex complementizing system. The present complementarity of that, for and WH follows from the analysis on which they are members of a single category introduced by the phrase structure rule $\bar{S} \rightarrow \text{COMP S}$ -- just as the complementarity of the modals follows from Chomsky's well-known analysis of the auxiliary (1957).

Since some syntacticians (e.g. Rosenbaum 1967) have supposed the for complementizer to underlie many infinitives, an apparent problem with the claim that WH is a complementizer is the existence of constructions like

56) John didn't know how to amuse himself in the forest.

57) The Boy Scouts wondered who to obey.

58) They couldn't decide whether to strike or not.

-- for in these examples there is both a WH and an infinitive. But in fact these sentences are not counterexamples to the phrase structure hypothesis, for there is evidence that such infinitives may be predictable from the deletion or case-marking of their subjects (Kiparsky and Kiparsky 1971; cf. n. 16). (56) probably derives from an intermediate form similar to

59) John₁ didn't know (how he₁ amuse himself in the forest)

by the deletion of the subject he₁ under identity to John₁ and the automatic formation of the infinitive. Evidence that infinitive-formation in these structures is the result of subject deletion and not of complementizer choice is provided by this fact: where the subject has no antecedent -- and hence deletion under identity is impossible -- the WH-plus-infinitive construction is impossible.¹⁴

60) *It is not known where to go.

(Cf. It is not known where he should go.)

61) *It doesn't matter what to do.

(Cf. It doesn't matter what one does.)

62) *Whether to strike or not depends on what to do.

(Cf. Whether we strike or not depends on what they do.)

(ii)

A second fact explained by the phrase structure hypothesis $\bar{S} \rightarrow \text{COMP } S$, where COMP includes WH, that, for, is this: in English that, for and WH occupy clause-initial position. On the phrase structure hypothesis this convergence is no accident. To illustrate, consider the fact that English has only one of the following possibilities for positioning that and WH, assuming that when occupies the hypothetical position of the complementizer WH:¹⁵

63) a. { She decided [that he should come] { [that S]
 { She decided [he should come when] { [S WH]

- b. { She decided [he should come that] { [S that]
 { She decided [when he should come] { [WH S]
- c. { She decided [he should come that] { [S that]
 { She decided [he should come when] { [S WH]
- d. { She decided [that he should come] { [that S]
 { She decided [when he should come] { [WH S]

On the transformational hypothesis (63a-d) are equally possible in any language; on the phrase structure hypothesis only (63c,d) are to be expected. (It is conceivable that a language could have two phrase structure rules introducing the same categories in different orders, but this would be highly unusual. Turkish may be an example of this unusual situation: although the clause particles are generally in clause-final position, there is a construction borrowed from Persian which has a clause-particle in clause-initial position (Andrews 1972). Chomsky's Base-Schema Hypothesis, which may be viewed formally as a device for "collapsing" phrase structure rules to express deep structure isomorphisms, would provide a way of reflecting the "markedness" of such cases as Turkish.)

(iii)

Further, that, WH, and for have the same overall distribution within English grammar. To make this assertion we must distinguish the WH-complement from the free relative. (See Baker 1969.)

In general, the semantic content of NP's in sentential complements to a predicate does not affect the semantic well-formedness of the predicate + complement reading; that is, verbal "selection" is not affected by NP's "below" the complementizer of the embedded clause. This proposition (call it P) can be illustrated as follows (the symbol # means "semantically ill-formed"):

- 64) #A marshmallow is a valid inference.
- 65) That his death was caused by a marshmallow is a valid inference.
- 66) #He proved the hot dog.
- 67) He proved the hot dog to have gained in popularity.
- 68) #The truth of her claim was asked more than once.
- 69) Whether the truth of her claim was in doubt was asked more than once.

If WH is a complementizer, then the above proposition (P) explains the examples (68) and (69) in a way parallel to the others.

This observation may seem to be rather pointless until it is applied to two sets of structures often confused -- the "free" relative clauses and the WH-complements. (See Baker (1969) for a discussion of their differences.) A free relative is a relative clause which begins with what, when, how, where, which, whatever, whenever, however, wherever, whichever, whoever -- for example, The dog will

eat what you feed it. The verb eat certainly prohibits sentential objects and, a fortiori, WH-complement objects.

Whatever the correct analysis of free relatives may be, it is clear that the semantic content of the head must satisfy semantic interpretation at two points: within the relative clause itself and within the matrix sentence. Thus, in the sentence

70) What he said is true.

what must "satisfy" both the verb said and the predicate phrase is true, just as in the case of a bound ("ordinary") relative clause:

71) Something that he said is true.

If the relative-clause and matrix verbs select different types of objects, the whole sentence is anomalous:

72) #Something that he ate is true.

73) #Something that he said was eaten.

The same is true in free relatives:

74) #What he ate is true.

75) #What he said was eaten.

Since neither the verb eat nor the predicate phrase be true is subcategorized for WH-complements (e.g. *Whether she did it or not is true), P does not apply to any of the above examples. But there are cases where P does apply, explaining otherwise extraordinary facts:

- 76) #The Administration wouldn't say something that
the general had eaten.
- 77) The Administration wouldn't say something that
the general had said.
- 78) The Administration wouldn't say what the general
had said.
- 79) The Administration wouldn't say what the general
had eaten.

Of these examples only (78) is (structurally) ambiguous between the free relative and the WH-complement constructions. Since say (unlike the verbs above) is subcategorized for WH-complements, (79) is well-formed, but unambiguous (because the free-relative version of (79) would be analogous to (76)). The possibility of (79) in the face of (76) is explained by P together with the hypothesis that WH is a complementizer.

Thus the WH complement belongs with the other complement types and not with relative clauses. This result still leaves open the possibility of two phrase structure rules $S \rightarrow WH\dots$ and $S \rightarrow COMP\dots$, rather than $\bar{S} \rightarrow COMP S$, where $WH \in COMP$. But as we shall see, the latter rule expresses significant generalizations.

As I have remarked, the overall distribution of WH, that, and for is the same. They occur in the following paradigms:

80) Object Complementation

I know that he is wise.

I prefer for you to speak English.

I am asking whether you will accompany me.

81) Subject Complementation

That he was alone was obvious from the report.

For you to leave right now would be inconvenient.

Whether he eats cabbage or not simply doesn't matter.

82) Nominal Complementation

The idea that nobody will survive is appalling.

The command for all troops to move out was given Friday.

The question whether they'll strike remains unanswered.

83) Copular Complementation

Your problem is that you are arrogant.

The command was for all troops to move out.

The main question is whether they will support us.

84) Adjoint Complementation

For his son to enjoy the army, he would have to try very hard.

Whether or not his son enjoys the army, he will try very hard.

That his son would not have to join the army, he joined himself.

Further, like recognized complementizers, WH can appear in multiple sentential complements to verbs:

- 85) How he acts early in the morning will show what he's really like.

Both how and what in (85) reflect the presence of underlying WH complementizers. And like recognized complementizers, WH shows subcategorizational dependencies:

- 86) Whether or not his mouth turns black will show whether or not he's been nipping at the silver nitrate.

- 87) *Whether or not his mouth turns black will show that he's been nipping at the silver nitrate.

- 88) *That his mouth is turning black will show whether or not he's been nipping at the silver nitrate.

Moreover, they are subject to many of the same transformations, such as Extraposition:

- 89) Whether they agree with us (or not) should not be as important as you make it sound.

- 90) That they agree with us should not be as important as you make it sound.

- 91) For them to agree with us should not be as important as you make it sound.

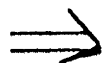

- 92) It should not be as important as you make it sound whether they agree with us (or not).

93) It ... that they agree with us.

94) It ... for them to agree with us.

And they are "extraposed over" in the same way:

95) It should not be as important whether they agree with us (or not) as you make it sound.

96) It should not be as important that they agree with us as you make it sound.

97) It should not be as important for them to agree with us as you make it sound.

Again, in "highest" or nonembedded sentences, both WH and that are obligatorily deleted.¹⁶

98) *That John is here.

99) *Whether John is here?

In embedded sentences, that and for are subject to optional deletion under various conditions:

100) I don't think (that) you should have said it.

I want very much for you to help me.

I want you to help me.

In some dialects, WH is deletable in embedded S's (Baker 1969); there are sentences like

101) He wants to know what's the trouble.¹⁷

But in subject position, all of the complement types are subject to the same restriction prohibiting the deletion of that, for, or WH:

- 102) *He was alone was obvious from the report.
 *You to leave right now would be inconvenient.
 *Does he eat cabbage or not doesn't matter.
 *What's the trouble is unknown.

A further generalization relating WH and COMP appears in considering facts like the following:

103) With whom did you speak?

104) *Behind what he is standing does not matter.

From (102) it is clear that WH cannot be deleted from a subject complement, while (99) shows that WH is (in fact, must be) deleted from a question. Examples (103) and (104) suggest, then, that in a WH-complement a preposition may accompany a fronted [+WH] word only in those types of positions where WH may be deletable.¹⁸ Now if WH is indeed a complementizer, this peculiar fact falls together with others under a stronger statement: in a clause, prepositions may precede moved constituents only where COMP is deletable. In the case of relative clauses, where that is deletable --¹⁹

105) She's a person that you can respect.

She's a person you can respect

She isn't half the statesman that her mother was.

She isn't half the statesman her mother was.

-- it is possible to prepose a prepositional phrase:

106) I know the boy who(m) you spoke with.

I know the boy with whom you spoke.

Similarly, in questions, where WH must be deleted, it is possible to prepose a preposition:

107) Who(m) did you speak with?

With whom did you speak?

In summary, WH, for, and that complements have the same overall distribution, and are subject to many of the same restrictions and transformations.²⁰

(iv)

A final argument that WH is a complementizer (or rather, pleasant consequence of assuming that it is) is provided not by particular syntactic or semantic facts, but by the form of a linguistic universal: I will show that if WH is recognized as a complementizer, Baker's "Q-universal" (Baker 1969) can be strengthened in a way which immediately explains an unsolved problem noted by Baker -- that of relating the universal behavior of relative clauses to that of questions. This result in turn leads to another possible universal and a means of relating underlying word order to the class of transformations possible in a language.

Baker's Q-universal is stated as follows (Baker 1969):

The first part of the hypothesis is that morphemes such as if and whether, and other words and particles in other languages in which such elements occur, are introduced into trees as lexical realizations of the Q morpheme... The second part of the hypothesis is that there is only one possible movement rule for questions, which differs in different languages only in the particular formatives mentioned in place of English wh [footnote 12 omitted]:

Q X NP Y
 1 2 3 4 → 1, 3+2, ∅, 4

Condition: 3 [dominates] wh.

Note that this statement is restricted to questions (embedded or not) and that it requires the existence of a special Q morpheme which is also a node dominating lexical element::.

If my hypothesis that WH is a complementizer is correct, then there is no such special node Q and the statement above must be reformulated in terms of the node COMP:

The Complementizer Attraction Universal

Only languages with clause-initial COMP permit a COMP-attraction transformation.

(Until a more thorough study is completed, the term COMP-attraction transformation may be understood informally to apply to any transformation moving a constituent (perhaps over an essential variable) into COMP position -- for example, Relative-Clause Formation and Question Formation, or WH-movement. There may be more than one such transformation in a given language.) This statement is not restricted to questions, but applies to any clause containing a complementizer which "attracts" elements of its clause over a variable into COMP position.

One such complementizer is the that appearing in relatives: Klima (1964) and Emonds (1970) give evidence that this

that is a complementizer, the same that appears elsewhere; evidence that it is not a pronoun is provided by the observation that relative pronouns may be the objects of prepositions (to whom, to which), but that never may: *the man to that I spoke. Moreover, it is well known that in many languages, relative clauses are introduced by a morpheme having the same shape as the declarative complementizer. Further, Emonds (1970) argues that some relative clauses are introduced by a for complementizer; thus the following sentences may be related by relativization rules:

108) The weapons for us to practice with are on the table.

109) The weapons with which to practice are on the table.

A more detailed discussion of Complementizer-attraction transformations and relative clauses may be found in Chapter 5.

If relative clauses are derived from complementized clauses, then the Complementizer-Attraction Universal immediately provides a solution to this problem noted by Baker:

...there is one interesting respect in which future research may show that this hypothesis [quoted above], rather than being too general, is not general enough. This is that such phenomena as the moving of relativized constituents in relative-clause formation may eventually be shown to be governed by essentially the same restrictions. In particular, in the languages for which I have relevant information, the movement of a relativized constituent occurs only when the modified noun is to the left of the relative clause, and then

only in a leftward direction. If this can be shown to hold true as a general rule, then it will clearly be insufficient to state two remarkably similar "universal" transformations without providing some explanation for their similarity.

The point to be emphasized here is that by recognizing Q to be a complementizer, two problems of universal grammar are solvable at once. It is totally obscure why relative clauses with heads to the left should be universally similar to clauses with question particles to the left (there is no evidence that relatives have the question morpheme: *the boy whether I saw is here; see Chapter 2); yet it is clear how clauses having leftward positioned complementizers are structurally alike. The necessary assumption is that relative clauses with leftward heads are derived from clauses with leftward complementizers:

RELATIVE CLAUSE

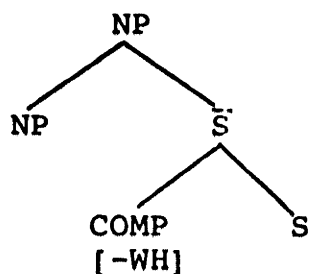

EMBEDDED QUESTION

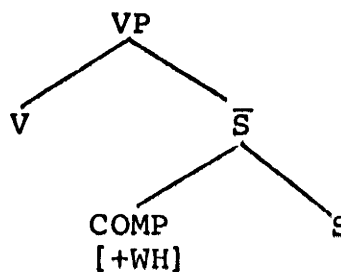

(This is not necessarily the deep structure of relative clauses: see Chapter 5.)

(I ignore the question of the exact labelling of nodes, in particular, whether \bar{S} should be dominated by NP.) In the nonembedded case there is also a structural similarity:

DECLARATIVE

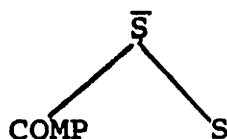

INTERROGATIVE

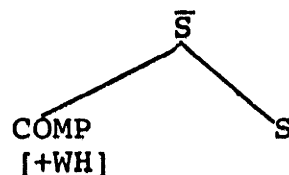

These structural similarities strongly suggest that it is the Phrase Structure rules which determine position of complementizers in a given language. Thus, it is no accident that English fails to have clause-initial that together with clause-final whether: *They knew he came whether, or clause-final how: *They knew he did it how.

To illustrate the Complementizer-Attraction Universal, consider an example from Japanese. (These facts about Japanese were related to me by Kinsuke Hasegawa.) This language has relative clause heads to the right and has no special rule for moving questioned constituents to initial position; thus in Japanese it is possible to ask questions unformulable in English:

(anata wa) dare ni nani o ageta hito ni atta no
 (you) who to what gave man met

desu ka = "You met a man who gave what to whom?"

(In English this sentence is possible only with "echo" intonation, but in Japanese it is a typical and normal interrogative form.) The Complementizer-Attraction Universal predicts that Japanese, a language having rightward complementizing, should have no Question Formation or Relative Clause Formation movement rules analogous to

those in English, and this is correct.

Above, I assumed that in languages having relative clause heads to the left, these clauses are derived from clauses with leftward complementizers. It is natural to ask what justification there is for this assumption. If it is the Phrase Structure rules which determine complementizer position, then this assumption amounts to the claim that languages with leftward heads of relatives have all complementizers positioned to the left; that is, if a language contains

$$R_1 \quad NP \rightarrow NP S,^{21}$$

then it contains

$$R_2 \quad \bar{S} \rightarrow COMP S.$$

In particular, this claim implies that question particles will be to the left. On the bases of the data in Greenberg (1962: universals 3, 4, 9, 12, 24 and Appendix I), apparently it is generally true that languages which have R_1 are just those which have clause-initial question particles, or R_2 . Here, then, is another possible universal:

The Expansion Universal

If R_1 belongs to the PS of the grammar of a language, then so does R_2 .

There may well be a deeper explanation for this fact in terms of universal constraints on Phrase Structure expansion, and the above formulation is highly tentative.

Given the Expansion Universal, notice that the Complementizer Attraction Universal may be restated as follows:

The Complementizer Attraction Universal

If R_2 belongs to the PS of the grammar of a language, then any member of T_i may belong to that grammar,

where T_i refers to the formally specifiable class of Complementizer-Attraction Transformations. Thus we have an obvious connection between underlying word order and the class of transformational rules possible in a language.²²

FOOTNOTES

CHAPTER 1

1. The term "complementizer" designating the particles that, for-to, Poss-ing, where Poss is the possessive ('s) morpheme, is due to Rosenbaum (1967:24-32). The essentials of the deep structure configuration (roughly) represented in (4) are also due to Rosenbaum (1967). To avoid considerations irrelevant to this study I have adopted this type of analysis throughout this chapter, although I believe that aspects of it may be incorrect.
2. See also Chomsky (1971a), Dougherty (1968), Kayne (1969), Helke (1969); it was Michael Helke who pointed out to me the fact that any transformation inserting complementizers would violate this proposed universal.
3. In Emonds (1970) it is argued that 's-ing is not a sentential complementizer, but a predictable reflex of the configuration [_{NP}S]. The relation between gerundive nominals [= 's ing complements] and sentential complements is open to question, and I will generally ignore the former.

4. For simplicity I have assumed here that \bar{S} expands only subordinate clauses (that is, that there are phrase structure rules such as $S \rightarrow NP VP$, $VP \rightarrow V \bar{S}$ in addition to (8)). Thus ill-formed strings like *That they imagined it may be avoided. In fact, I believe that all S's, embedded or not, have "complementizers"; these are deleted from nonembedded S's, obligatorily in English but not in some other languages (Ross 1968). In Section C of this chapter I associate declaratives with the deleted that and interrogatives with the deleted WH. (See n.16 on for.)
5. Chomsky (1965:99) provides a definition of strict subcategorization which entails that it is only "frames dominated by VP that determine strict subcategorization of Verbs", for example, the object NP or Adverbs of Manner. Independent evidence in favor of extending the domain of strict subcategorization rules is presented in Kajita (1967:94-108). For example, such verbs as serve, help, suffice must be subcategorized for the sequence V NP (that is, transitive verbs) within their complex complements:
- The ice melted
- *The ice served to melt
- The ice chilled the beer
- The ice served to chill the beer
- [example from Kajita (1967:103)]
- Therefore, it requires no special extension of grammatical

theory to account for the selection of complement types, given the phrase structure theory of complementizers, if it is a matter of strict subcategorization. Chomsky has suggested (personal communication) that selectional restrictions may be a more appropriate means of describing these phenomena.

6. But compare I mean for you to do well, where mean is closer to intend. In Chapter 2, I discuss the semantic function of for in "intentional" contexts.
7. This was pointed out to me by Chomsky. (Cf. Chomsky (1957:72ff).)
8. This argument is due to Morris Halle and J. R. Ross. An argument for the cyclicity of There-Insertion is given in Bresnan (1971b:264, n.5).
9. The possibility that COMP-insertion might be a precyclic transformation will lose any plausibility it may have when it is seen in section C of this chapter that many generalizations are gained by treating WH as a complementizer: it will be clear that a complementizer-insertion transformation would have either to change fundamental semantic interpretation by inserting WH or else lose these generalizations by inserting the other complementizers only. Chapter 2 will strengthen this argument by showing that each of

these complementizers has a semantic function.

10. The location of both is a key to determining whether (37) or (38) is the source for a given instance of conjunction reduction:

i) For Kip to fly to N.Y. and for Mary to fly to

N.Y. would both be { strange occurrences
*a strange occurrence }

ii) For Kip and for Mary to fly to N.Y. would both be

{ strange occurrences
*a strange occurrence }

iii) For Kip and for Mary both to fly to N.Y. would be

{ *strange occurrences
a strange occurrence }

(i) and (ii) would come from a structure like (37), but

(iii) would come from one like (38). Thus, although (ii)

and (iii) may have virtually identical surface structures,

the position of both signals their distinct sources, which

in this case is confirmed by the meaning and the number in

the predicate.

I assume that (i) and (ii) are derived in roughly the following fashion:

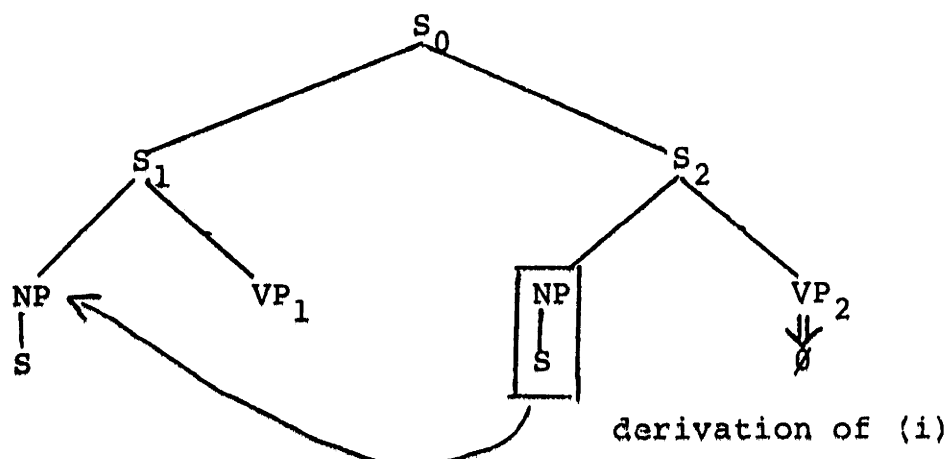

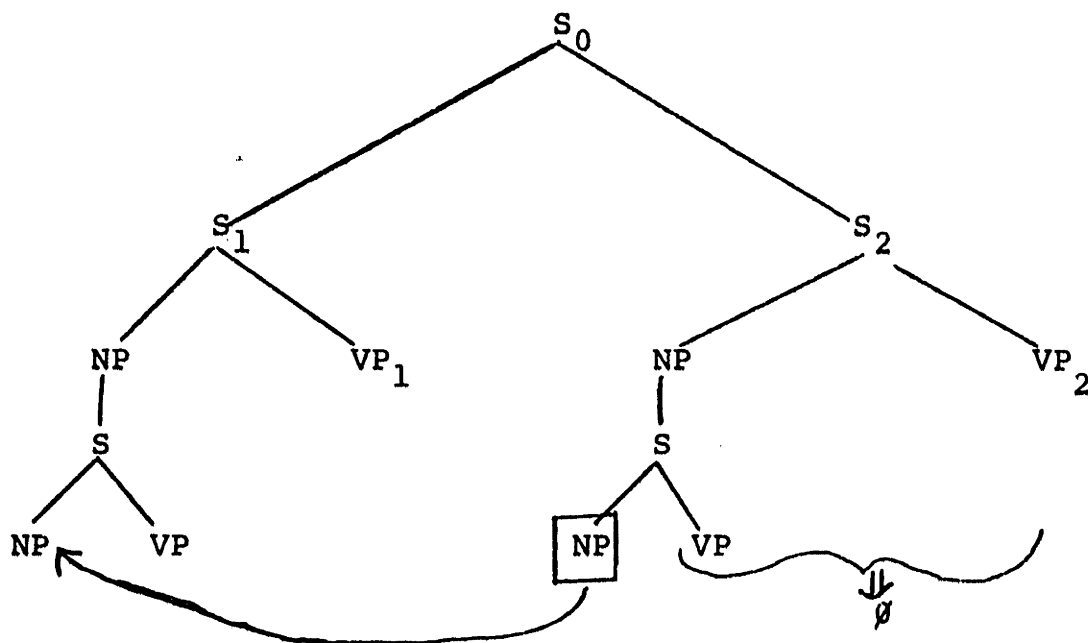

derivation of (ii)

The amount of redundant material deleted is optional: it could be either would be a strange occurrence or to fly to N.Y. would be a strange occurrence.

This type of derivation would require that the insertion prohibition not apply to coordinate or parallel nodes, a modification which is required anyway to permit interpolation in such cases as If I have not been deceived, this idea will stun them. \implies This idea, if I have not been deceived, will stun them. Instead, insertion of material from a domain A into a domain B would be prohibited if and only if B is "below" A syntactically (i.e., if B is commanded by A but A is not commanded by B).

11. George Lakoff (personal communication) has suggested to me that (42) and (43) could be derived from a structure like

(38) by withholding Conjunction Reduction until the S_0 node after Complementizer Insertion had applied. He gives the sentences (a)-(c) as evidence for this possibility:

- a) For Nixon to praise the USSR would be a strange occurrence and for Chomsky to praise the USSR would be a strange occurrence.
- b) For Nixon to praise the USSR and for Chomsky to praise the USSR would both be strange occurrences.
- c) For Nixon and for Chomsky to praise the USSR would both be strange occurrences.

He assumes that (a) reduces to (b) and then (b) to (c), concluding that if (b) can reduce to (c) by an application of Conjunction Reduction on the topmost S, then Conjunction Reduction could apply to (38) on S_0 to yield (42) and (43).

However, Lakoff's conclusion does not follow. First, (a) may reduce directly to (c), just as in the derivation of (ii) in n. 10. Second, even if (b) could reduce to (c) by having Conjunction Reduction "reach down" into a conjoined subject from the matrix S, we still could not derive the crucial sentences (42) and (43) by this means. For in the derivation of (c), both cannot be positioned as in (42) or (43): otherwise an ungrammatical sentence analogous to (iii)* in n. 10 will result. Likewise, in the derivation of (42) and (43), both cannot be placed as in (c): *For Kip and for Mary to fly to New York would both be unusual. (cf. (ii)* in n. 10).

Further, "withholding" Conjunction Reduction to apply to an S which does not immediately dominate conjoined nodes violates the principle of strict cyclicity (Chomsky 1971a, Bresnan 1971a, Kean 1972) and complicates the statement of the rule with otiose variables.

12. In this section I am presupposing the distinction between "embedded questions" and "free relatives" that is the source of the ambiguity in I don't know what John knows. (Jespersen MEG III:72-77; Baker 1969). The WH complementizer is not present in relative clauses. Moreover, I distinguish the interrogative (WH) complementizer from a feature [+WH] which is associated with lexical items or pro-forms (yielding the "interrogative pronouns" who, why, how, etc.) and whose distribution is a function of the WH complementizer. Because the question formation transformation inserts [+WH] items "into" the WH complementizer, it happens that WH, unlike for and that, is seldom "observable". I believe that it appears fused with either in whether. (See Hasegawa 1969; Katz and Postal 1964). Though if is related to whether, I do not identify WH with if, for they differ in distribution: Whether he'll come is not known vs. *If he'll come is not known. (Jespersen MEG#III: 41ff; Gane 1969.) Rosenbaum (1967:32, n.1) writes: "A second major class of complementizers with which this study does not deal includes the wh complementizer..." The examples he gives, however, include "free relatives"

as well as WH complements. Furthermore, if WH has a semantic function, it is presumably not to be introduced by transformation, but Rosenbaum does not pursue this consequence for his analysis of other complementizers.

13. See Klima (1964).

14. A possible exception to this generalization is the how to construction: There was no indication of how to..., It is not known how to... How to... is also exceptional in permitting extraction under Question Formation: cf.
What do you know how to do? to *What do you know $\left. \begin{array}{l} \text{whether} \\ \text{when} \\ \text{where} \end{array} \right\}$
to buy?

15. Why could these not be shifted by transformations from their phrase structure position in the course of a derivation? An answer to this question is provided by the Structure Preserving Hypothesis. The class of structure preserving transformations (which may be identical with the class of cyclic transformations) is constrained so that each string transformed by a structure-preserving transformation preserves certain properties of base strings; thus the string S COMP could not be mapped by such a transformation into the string S COMP in English. Only non-structure-preserving transformations -- root transformations

(possibly identical with post-cyclic transformations) and "minor movement rules" (which perform highly restricted operations: see Emonds 1970) -- could shift COMP. Neither class could yield the type of examples shown.

16. It is natural to ask what happens when for is chosen as the complementizer for a nonembedded sentence. There is evidence (Emonds 1970) that the for complementizer has the syntactic properties of a preposition and that there is a transformation which moves the subject of the embedded S into the object position of for, as diagrammed:

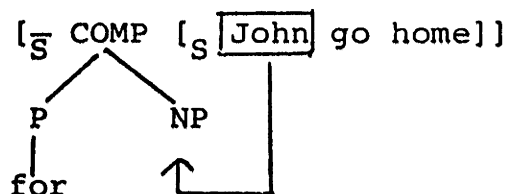

This would allow one to predict the occurrence of to as in other cases (Kiparsky and Kiparsky 1971). If \bar{S} is not embedded, then the COMP must be deleted. But the deleted object of for would not be recoverable, and hence the obligatory COMP-deletion rule would fail to apply and the sentence would be ruled ungrammatical. If for occurs on topmost S's, subjectless sentences would result only where the underlying subject is recoverable. It is interesting that many generative grammarians have assumed you to be recoverable in deriving imperatives (e.g., Katz and Postal 1964). Sentences like Wash yourself! give evidence that you is the underlying subject of imperatives. Therefore it may be possible to associate for with the English

imperative, just as WH and that are associated with the interrogative and declarative, respectively. (See Chapter 3 for more about for complements.)

Note that on this analysis the difficulties in relating the semantic interpretation of imperatives to the interpretation of other for-complements (for a discussion of which see Ch. Two) are quite similar to the problems in relating the interpretations of questions and so-called "embedded questions":

She knows how you must be feeling

?How must you be feeling?

They have yet to decide whether you may take Bonzo
along

?May you take Bonzo along?

17. When the WH complementizer is deleted, as in nonembedded sentences, subject-verb inversion is possible. I am assuming that in the sentence What did he do? the WH complementizer has been deleted, even though a [+WH] word, what, remains. (Cf. n. 13.)
18. An exception is the case of "absorbed prepositions": these are prepositions which always adhere to their objects (e.g., At what point did they fail? but not *What point did they fail at?); they cannot be stranded, but must accompany their objects, even in a sentence-initial WH-clause.

Compare At what point they failed remains unclear to (104).

19. For evidence that that in relative clauses is a complementizer, see Jespersen (MEG#III), Emonds (1970), and Chapter 5 below.

20. One respect in which WH-complements differ from that- and for-complements is that the former may appear with prepositions, as in

the question of whether S

the idea (*of) that S

the decision (*on) for S.

This difference may be explained as follows. If we suppose that to be the "unmarked" complementizer, we may assume that only the WH and for complementizers actually need be marked in deep structure. A later transformation will insert that into unmarked COMP nodes. Independently, it appears that prepositions are deleted before empty nodes and before other prepositions. As already noted (n. 16), for has prepositional properties. This fact, together with the late insertion of that, would explain the absence of prepositions before non-WH complements.

21. If R_1 is not the deep structure source for relative clauses (as would be the case if they originated in the Determiner, for example), the Expansion Universal must be reformulated. See Chapter 5 for some discussion of this.

22. Kenneth Hale (personal communication) has brought to my attention some evidence showing that Baker's Q-Universal or my generalization of it may be wrong. The evidence is from Navajo, which, according to Ellen Kaufman (1972), has a clause-final interrogative complementizer and a movement rule which attaches material to it. Several peculiarities of this case suggest, however, that Navajo may not be inconsistent with Baker's or my hypothesis. According to Kaufman, the question word (distinct from the complementizer) is deleted, not moved, in subordinate clauses (as we would expect from Baker's hypothesis); but if the question word is modified by a spatial enclitic, that enclitic is attracted to the complementizer subsequent to the deletion. It turns out that the complementizer is also a tense marker and itself enclitizes upon the verb, so that both enclitics are found in the verb, and not in underlying COMP-position. It is possible that the characterization of T_i can be refined so as to exclude the spatial encliticizing rule in a well-motivated way; it is also possible that spatial encliticizing follows the encliticizing of the complementizer, thus avoiding violation of the universal. Further study is needed of this and other cases before accurate conclusions can be drawn.

CHAPTER 2

THE SEMANTIC FUNCTIONS OF THE PREDICATE COMPLEMENTIZERS

Complementizers have distinct semantic functions which affect their compatibility with various predicates. In this chapter I will give a preliminary characterization of the semantic differences among WH, that, and for. From (1) it is obvious that such meaning differences exist:

- 1) a. She never said that we should leave.
- b. She never said whether we should leave.
- c. She never said for us to leave.

To "say that" is to make a definite statement; to "say whether" is to state a decision; to "say for" is to enounce an order. It is well worth stressing that (1c) is not to be derived from (1a), for the two differ subtly, but distinctly, in meaning. (1c) is both less specific and more "performative" than (1a). Note the difference between (2a) and (2b):

- 2) a. She didn't say for us to leave, but she said that we should leave.
- b. She didn't say that we should leave, but she said that we should leave.

(2a) has the meaning, "She didn't tell us to leave, but she said that we should"; (2b) is self-contradictory. The difference is also brought out in (3):

- 3) a. I (never) said that unicorns should exist, if
chimeras do.
- b. ?I (never) said for unicorns to exist, if
chimeras do.

If we abstract away from the modals, auxiliaries, and complementizers in (1), we are left with the plain content of the complement: we leave. The choice of complementizer affects how this plain content is viewed -- as something particularized or definite, as something undetermined or open in some respect, or as something "intentional" (seen as a goal or subjective reason).

WH

It is easiest to see that WH has a distinct inherent meaning, although it is a somewhat subtle matter to characterize it accurately. A clause prefixed by WH may have a number of interpretations, depending upon both the semantic content of the higher predicate and the auxiliary within the complement. But there is, in addition, an invariant residual meaning which we may assume is contributed by the WH morpheme itself. In isolating the meaning of the WH complement type, therefore, one must abstract away from the contributions of these various predicates and auxiliaries.

For example, it is inadequate to characterize the semantic

value of WH as "request for information", for while that description may be compatible with the meaning of the complements in (4), it does not apply to (5):

4) I'll ask whether Linda is coming.

She inquired who was coming.

They wonder when they'll be allowed to leave.

5) (We have refused your request because) we doubt whether you're capable.

They debated whether conclusive evidence had been presented.

It's uncertain what they'll decide to do.

I know who said that, but I won't tell you.

Tomorrow Dr. Smith will announce whether she'll run.

It is clear from (4) and (5) that the interpretation of the WH complement may range from interrogative to dubitative, depending on the higher verb.

A closer approximation to the effect of WH comes from viewing it as a semantic function on determiners (cf. Baker 1969). These determiners include, e.g., some, so, that in some woman, so old, that one; and (assuming with Postal that pronouns are syntactically related to determiners) then, there, etc. For X such a determiner, WH(X) means "reference of X is undetermined". Thus we might have

- 6) WH(some) = what
 WH(so) = how
 WH(that) = which
 WH(then) = when
 WH(there) = where

Ordinary questions might have interpretations as indicated in (7a):

- 7) a. Which one did you like? = You liked WH(that) one: undetermined reference of that
How old are you? = You are WH(so) old: undetermined reference (i.e. degree) of so
What woman first received an M.D.? = WH(some) woman first received an M.D.: undetermined reference of some

"Embedded questions" would be interpreted as in (7b):

- 7) b. She asked which one you liked = She asked [you liked WH(that) one; undetermined reference of that] i.e., "She asked the reference of x in you liked x one"
I know how old you are = I know [you are WH(so) old: undetermined reference of so] i.e., "I know the reference of x in you are x old."
What woman first received an M.D. isn't widely known = [WH(some) woman first received an M.D.: undetermined reference of some] isn't widely known, i.e., "The reference of x in x woman first received an M.D. isn't widely known."

Finally, if we add the exclusive either to our list of "determiners", we can uniformly derive yes/no questions as follows (cf. Katz and Postal 1964):

- 8) Did John come (or not)? < Whether did John come or not = WH(either) John came or not: undetermined reference of either (i.e. choice undetermined).

Whether would be deleted from matrix sentences.

This analysis of yes/no questions accounts for the absence of exclusive either in such questions:

- 9) Either John came or not.

*Did either John come or not?

Further, it extends to questions which lack a "+wh" word on the surface, but cannot be answered by yes or no:¹

- 10) Did John [´]come or Mary [`]leave? = WH(either) John came or Mary left: undetermined reference of either (i.e., choice undetermined).

Cf. *Did either John [´]come or Mary [`]leave?

- 11) Did you talk to [´]John or [`]Mary? = You talked to WH(either) [´]John or [`]Mary: undetermined reference of either (i.e., choice undetermined).

Cf. *Did you talk to either [´]John or [`]Mary? (Not to be confused with "Did you talk to either John or [´]Mary (or [`]not)?")

In summary, WH is a function on determiners, mapping either, so, some, etc., onto whether, how, what, etc. In a sense, WH "undetermines" a particular part of the complement it

governs. What is "undetermined" is well defined: WH picks out a specific semantic gap (or several such) in a domain which is otherwise semantically complete. The WH complement may thus be compared to the "open sentence" of logic. An open sentence is essentially a sentence containing free variables (e.g., "x saw John at time y"), it can be neither true nor false. This comparison may in fact yield some insights into the anomaly of certain types of questions. In order for a choice between alternatives to make sense, the alternatives must be semantically complete. It is anomalous to use a whether complement which contains a semantic gap within the disjuncts: *Did who see Mary or not? *He doesn't know whether or not Mary saw who. *Did John talk to you or did you talk to who? In general, one may have "parallel gaps" but not "gaps under gaps". Who did what? is of the semantic form "x did y: x and y undetermined"; there are no gaps under gaps.

From this characterization of the meaning of WH, we can more naturally describe what semantic class of predicates will permit WH complements. Interrogative and dubitative predicates leave aspects of their complements open to question; they are compatible with "undetermined", semantically open complements. On the other hand, predicates which assert or presuppose truth value, or which imply knowledge or certainty, should resist WH complements.

- 16) #It's (not) true whether he came.
 #It's false when he left.
 #They haven't claimed whether we owe them money
 or not.
 #Mary denied whether she was a doctor.

- 17) #I am surprised whether Christine won.
 #Whether or not she won is tragic.
 #They were dismayed about whether you were angry.

(Note that the WH complement must be distinguished from the free relative, e.g., "It's false, what you said.") The semantic function of WH may also explain its incompatibility with desideratives and imperatives, which imply that the described state of affairs must be brought about or realized, and thus may require semantic completeness of the description:

- 18) #He commanded whether we should go.
 #It is imperative who sees you.
 #Whether you win is most desirable.

Nominals behave in entirely the same way: his doubt about whether...; his uncertainty (as to) whether...; #the fact (of) whether...; #his command (of) whether to go....

The characterization of WH as an "undeterminer" suggests why WH complements occur with intrinsically interrogative and dubitative predicates, such as ask, inquire, wonder, doubt, be uncertain, debate, consider, decide, judge, be open (as in It's still open whether we're going.). It also

suggests why certain predicates, which sometimes seem incompatible with WH complements, nevertheless occur with WH in contexts implying uncertainty or "openness":

- 19) a. #It's clear whether he's going.
 b. It's not clear whether he's going.
 c. Is it clear yet whether he's going?
 d. It will be clear whether he's going (or not) as soon as we see his face.

Other examples are not know, not say, not tell, not reveal, not be certain. The WH complement is often exploited in holding back, concealing, or deliberately leaving open certain information: I know who's to blame (but I won't tell you); It's clear what must be added to the solution; To an experienced engineer like Mary, it's immediately obvious whether a device like this will work, (but to me it's not at all clear at first).

The analogy provided by the open sentence suggests other possible contexts for WH complements, in addition to the interrogative, dubitative, and concealing contexts -- for example, "relational" predicates (depends on, is related to, is connected to, is concerned with) and other predicates which may be neutral with respect to the truth value of the complement (matters, is irrelevant).

There is one other facet of the meaning of WH complements which will be useful for comparative purposes. One can

ask for permission or instructions as well as for information; similarly, one can be uncertain about what is permissible as well as about what is true. Desiderative and imperative predicates characteristically disallow past-time references within the complement, regardless of choice of complementizer: #He is asking that we have done it yesterday; #He is asking for us to have done it yesterday; #He is asking what to have done yesterday. This future-subjective character is clearly imposed by the higher predicate and cannot be considered an inherent feature of the complement type: some predicates can be used to elicit permission or instructions, or to express uncertainty about such things --

20) They are wondering what to do.

Ask him when to stop.

She wouldn't tell me how to finish it.

He's trying to decide whether to disqualify himself.

I am uncertain who to speak to about this.

-- and some cannot:

21) #He'll announce whether to run.

#It doesn't matter to me what to do.

The semantic description of WH must apply to such future-subjunctive complements as well as to indicatives. Thus, I avoided using the notion of truth value in defining the semantic function of WH: the WH complement in He is trying

to decide whether to disqualify himself does not include the meaning "truth value undetermined", for the notion of truth value does not clearly apply to commands, permission, or instructions. Instead, what is undetermined is the choice of alternatives. Thus, the characterization of WH extends across subjunctives and indicatives.²

that

A semantic function of that is also isolable, despite wide variations imposed by various predicates, moods, and auxiliaries. The function of that is to "definitize" a complement, and may be felt most easily in minimal pairs with the other complementizers. Consider the following contrasts between that and WH:

- 22) a. It has already been decided whether you can go -- but I can't tell you the outcome.
 b. It has already been decided that you can go -- #but I can't tell you the outcome.
23. a. We could not agree whether Mary was justified -- #in fact, we could only conclude that she wasn't.
 b. We could not agree that Mary was justified -- in fact, we could only conclude that she wasn't.
24. a. We had no idea whether we were on the right track -- and, as it turned out, we weren't.
 b. We had no idea that we were on the right track -- #and, as it turned out, we weren't.

The difference between the (a) and (b) members of these examples is quite palpable.

A more subtle case is provided by a special type of locution (brought to my attention by Alan Prince): the sentence I don't know that I agree with you can be used to express polite disagreement, and it differs only slightly from I don't know whether I agree with you. (Cf. I'm not sure that I go along with that vs. I'm not sure whether I go along with that.) The greater politeness associated with the first cases might be attributed to the presence of that: as a definitizer it allows greater recognition of the status of the complement; the complement is a definite given from which the speaker politely dissents. By contrast, WH leaves the status of the complement open; nothing is given.

There are predicates whose semantic structure precludes a that complement: inquire, question, be undetermined, be undecided, be undecidable. Some of these examples provide an interesting contrast, e.g., be undetermined vs. not be determined:

- 25) a. It is still undetermined whether she has escaped.
- b. #It is still undetermined that she has escaped.
- 26) a. It has not yet been determined whether she has escaped.

- 26) b. It has not yet been determined that she
has escaped.

(26b) suggests that one can deny determinateness of a that-proposition, but (25b) shows that when the denial of determinateness is built into the predicate, the that-complement is inappropriate.

The predicates which select that-complements are those which are compatible with a definite, specific proposition. Here I will give several instances showing the greater definiteness or specificity of that-complements compared to for-complements. (For will be discussed in more detail in the next section.) Consider first (27a, b):

- 27) a. It's rather odd that a man is chairing a
women's meeting.
b. ?It's rather odd for a man to be chairing
a women's meeting.

Speakers vary quite a bit in their acceptance of for-complements in contexts like (27b). Some find it somewhat unacceptable, others use it readily. However, if we modify the example slightly, we can produce a strong reversal of acceptability:

- 28) a. #It's always rather odd that a man is
chairing a women's meeting.
b. It's always rather odd for a man to be
chairing a women's meeting.

Whereas in (27a) that is completely normal, in (28a) it is

anomalous. Meanwhile, for has gained sharply and sounds quite normal in (28b), to my ear. What is the reason for this difference?

A related effect can be produced with a modal:

- 29) a. It would be odd that a man is chairing
a women's meeting (but for the fact that...)
- b. It would be odd for a man to be chairing
a women's meeting.

(29a) presupposes that a man is chairing a women's meeting, and asserts that this fact would be odd (under what conditions is not specified). (29a) is like (28a) in that the contents of the that-clause are not taken under the scope of the predicate operator (always, would). Just the opposite is true of the for complement, which is open to, and may even require, a "modal" context.

It's clear that in some way the that-clause implies greater definiteness than the for-clause. That seems to seal off its domain from external time quantification and modality. One way of grasping this phenomenon is to conceive of that as itself a kind of "definiteness" operator. As a provisional representation, the following very rough analogy may clarify the phenomenon; compare (27) - (29) with (30) - (32):

- 30) a. $\left\{ \begin{array}{l} \text{The} \\ \text{That} \end{array} \right\}$ elephant in the living room is odd.
 b. An elephant in the living room is odd.
- 31) a. ? $\left\{ \begin{array}{l} \text{The} \\ \text{That} \end{array} \right\}$ elephant in the living room is
 always odd.
 b. An elephant in the living room is always
 odd.
- 32) a. $\left\{ \begin{array}{l} \text{The} \\ \text{That} \end{array} \right\}$ elephant in the living room would be
 odd.
 b. An elephant in the living room would be
 odd.

The meaning of (31a) might be restated as "There is a particular elephant x in the living room such that for all times t , x is odd at time t ". (31b), by contrast, really means something like "Any time you have an elephant in the living room, it's odd (an odd time, an odd situation)". (It also has the odd meaning "a particular elephant... is always odd".) Now compare (28): instead of "elephant in the living room" we have "event in which a man is chairing a women's meeting". (28a) means "There is a particular definite event x , in which a man is chairing a women's meeting, such that at all times t , x is odd at time t ." (28b) means "Every time you have an event in which a man is chairing a women's meeting, it's odd (an odd time, situation)." The anomaly of (31a) is thus entirely similar to that of (28a): a single, definite thing or event is asserted to be odd for all time. It might be an interesting exercise to analyze (29) and (32) along these

lines; however, the above sketch is intended only to illustrate a means of viewing the semantic function of that. The analogy with articles is very imperfect.³

It could be objected that we cannot attribute the above differences to the complementizers alone, since the auxiliaries within the complements differ, that occurring with a finite auxiliary and for with an infinitive. However, even when we choose a nonfinite verb within the that complement, a difference in definiteness can be found between that and for, as we shall see. Thus there is apparently no need to postulate for English both "that + subjunctive" and "that + indicative" complementizers. As with WH, the semantic value of that is independent of "mood". One problem with proving this point is that the kinds of predicates which permit subjunctive complements have a number of special semantic properties which complicate things. Such predicates, including be imperative, be urgent, be desirable, be necessary, be essential, are themselves like modal operators. I cannot find compelling evidence for a definiteness reversal parallel to that with odd above:

- 33) a. It is always desirable that housework be done by a woman.
- b. It is always desirable for housework to be done by a woman.

- 34) a. It would be desirable that housework be done by a woman.
- b. It would be desirable for housework to be done by a woman.

However, there are other facts which suggest the greater definiteness or specificity of that + subjunctive compared to for.

Consider nominal forms of predicates which take the subjunctive: just as we have John proposed that funds be raised, we have (35a):

- 35) a. John made a proposal that funds be raised.
- b. John made a proposal for funds to be raised.

Is there a difference in specificity or definiteness between (35a) and (35b)? Apparently so, for consider (36):

- 36) a. ?John made one proposal after another that funds be raised.
- b. John made one proposal after another for funds to be raised.

Intuitively, (36a) sounds bad because the that complement is quite specific, "pinning down" the proposal being made, while the for-complement provides a description non-specific enough to subsume several distinct proposals.

Similar to (35)-(36) are (37) and (38):

- 37) a. We ignored his plea that we help him.
 b. We ignored his plea for us to help him.
- 38) a. ?We ignored his repeated pleas that we
 help him.
 b. We ignored his repeated pleas for us to
 help him.

The greater specificity of that-complements suggests a certain literalness with verbs of speaking, implying a fairly close paraphrase of some given utterance. This can be felt in the following examples, where the that complement is odd because no utterance is implied:

- 39) a. ?The dog demanded that she be fed.
 b. The dog demanded to be fed (by pressing herself against the refrigerator door and refusing to move).

The facts considered in this section show that the that complementizer has a semantic function distinct from WH and for.

for

One of the most interesting particles in English is for, whose function as a complementizer is apparently virtually unique to this language.⁴ Jespersen traces the syntactic evolution of the preposition for into what we would call

a true complementizer (MEG V, pp. 308ff.). One clear sign of its present status as a complementizer is that practically any noun phrase can occur as its "object", even the expletive there:

- 40) It would be catastrophic for the economy for there to be a sudden massive influx of women into the job market.

The preposition for does not have this leeway: *It would be catastrophic for there; #It would be catastrophic for a sudden influx. A second sign is that the for complement, like the that complement, can occur as a subject:

- 41) a. That John chuckles a lot indicates that he is jovial.
 b. For Mary to giggle a lot would indicate that she is silly.

Several characteristics of the for complement are summarized by Jespersen (MEG V:314):

Through the development of the last few centuries English has acquired a much used construction for + S[subject] + infinitive, which forms a convenient supplement to the ordinary S[subject] + infinitive as object of a verb ('accusative with infinitive') as it can be used in a number of cases in which the other construction is not possible, thus

- (a) in the beginning of a sentence: for a man to tell... is hard.
- (b) separated from the governing verb: what I like best is for a nobleman to marry..., cf. I like a nobleman to marry...
- (c) after than and as: nothing can be more absurd than for a prince to employ...
- (d) after substantives: it is my wish for you to be happy; cf, I wish you to be happy -- and adjectives: I was so impatient for you to come.

I will assume that for is present in the deep structure of cases like I like a nobleman to marry... and I wish you to be happy, but is deleted under certain conditions when contiguous to a verb. (See Chapter 3.)

The for complementizer is discussed by Rosenbaum in his influential work on predicate complementation (1967).

However, in Rosenbaum, as in much later work, for has been assumed to underlie all infinitival S-complements:

linguists almost seem to have been working under the motto,

"Where to appears, for was there." Thus they would have

for underlie (i) I believe him to be helpful as well as

(ii) I like him to be helpful. Since for can actually only

be justified for a restricted subclass of these comple-

ments, it is not surprising that no intrinsic meaning was

felt to reside in for-complements. (The syntactic basis

for the distinction between (i) and (ii) is given in

Chapter 3.) Jespersen, however, had astutely observed

that the presence of for has a semantic effect on the

complement (MEG V:304):

It should be noted that in nearly all sentences the combination of for and an infinitive denotes some vague possibility or something imagined.

Take, e.g. ...He was ashamed for the Japanese to see it = ashamed at the thought that the J. might possibly see it; here "ashamed of the J. seeing it" would imply that they did see it.

We have already seen that for complements are in some ways less specific or definite than that complements, but

it is inadequate to characterize the meaning of for merely in terms of specificity. For one thing, such a characterization would not explain why verbs like believe, consider, doubt do not occur with for: *He believes somehow for Frank to be here; *What I believe is for Mary to be shy; *They doubted very much for me to be capable. Nor would it explain Kiparsky and Kiparsky's observation (1970:169) that for complements are limited to the class of "predicates which express the subjective value of a proposition rather than knowledge about it or its truth value."

The key to the meaning of the for complementizer lies in the meaning of the preposition for. There is a relationship between the semantic functions of the complementizer and those of the preposition. Consider, for example, the following correspondences.

- 42) a. He considers her a fool {for her generosity.
for being so gener-
ous to him.
to let herself be
used by him.
- b. He considers it foolish for her to help him.
- c. You're a bastard {for doing that.
to do that.
- d. It's a sin for you to do that.
- 43) a. This book is {for your amusement.
for you to amuse yourself with
while I'm away.

43) b. A guy like John would be good

{for long talks.
 {for talking to.
 {for you to talk to about your problems.

c. I'm aiming {for victory.
 {to win.
 {for my team to win.

d. She hopes {for many things.
 {for her sisters' liberation.
 {for her sisters to be liberated.

It can be argued that the preposition for is present in the underlying structures of many of these examples (in addition to the complementizer), but is deleted before the for complement. Even so, we can infer that for as a complementizer has a meaning compatible with this range of uses of for as a preposition. That complements cannot be substituted in the same range of constructions: #You're a bastard that you do/did that; #I'm aiming that my team will win; ?This book is that you might amuse yourself with it.

The examples in (42) illustrate the use of for to express subjective reason or cause (i.e., the reason for attribution or judgment). In (42a), her generosity or willingness to be used is the reason he considers her a fool; in (42b), "for her to help him" not only describes something considered foolish, but suggests the subjective cause for his emotive reaction or moral judgment. In (42c, d) the for phrases describe the source of the speaker's reaction or judgment. The examples in (43)

Upon examining the uses of the for complement where it is independent of the preposition for, we again find two broad types corresponding to (44) and (45). The first type of use is with the emotive factives such as surprise, astound, etc. (Kiparsky and Kiparsky 1970); here we find that references to past time (with respect to the matrix) are possible:

- 46) Is it really so crazy for Valerie to have
shot him (yesterday)?

The second type of use is with desideratives or "imperative" predicates:

- 47) It's absolutely imperative for Nell to feign
stupidity.

Note that past-time expressions (with respect to the matrix) are not possible in (47):

- 48) #It's absolutely imperative for her to have acted
stupid yesterday.

Many, but not all, of the latter type of predicates can also occur with that + subjunctive, although none of the former type does.

Predicates which describe moral judgments or emotive reactions are thus compatible with the motivational or intentional for complement, and (perhaps in an extended sense) fit schema (44). Those which describe desires, commands, urgency and the like, are also compatible with the for complement, but fit schema (45). By contrast, predicates

which presuppose or imply objective knowledge of truth value are semantically incompatible with the intentional complementizer for:

49) #It is true for God to exist.

#It is false for there to be only finitely many primes.

#It is clear for these houses to be occupied.

#I $\left\{ \begin{array}{l} \text{believe (with good reason)} \\ \text{know (for a fact)} \\ \text{assume (on these grounds)} \\ \text{infer (from the above)} \end{array} \right\}$ for them to

win unfairly.

Compare (49) to (50):

50) It is right for God to punish sinners.

It is wrong for there to be such inequalities.

It is illegal for these houses to be occupied.

I consider it unfair for them to win all the time.

The examples in (50) illustrate the "moral judgment" predicates. Those in (51) exemplify the "emotive reaction" predicates.

51) It is $\left\{ \begin{array}{l} \text{offensive} \\ \text{crazy} \end{array} \right\}$ for a man to act that way.

It would $\left\{ \begin{array}{l} \text{surprise} \\ \text{astound} \\ \text{worry} \\ \text{impress} \end{array} \right\}$ me for a man to act that way.

Those in (52) typify the desiderative-imperative predicates:

52) It is $\left\{ \begin{array}{l} \text{necessary} \\ \text{imperative} \\ \text{desirable} \\ \text{required} \end{array} \right\}$ for disguises to be worn.

I want very much for you to come.

The subjective aspect of the for complement allows it to be interpreted as describing unrealized states of affairs, both future and hypothetical, and even simply non-specific. While the that complement preserves factivity even under modality, the for complement does not. Thus (53) presupposes the fact that "she said that":

- 53) I would be surprised that she said that (if I hadn't heard it already).

But (54) has no such presupposition:

- 54) I would be surprised for her to have said that.
 (54) has the paraphrase "I would be surprised if she had said that."

Sentences like (54) might suggest that these for complements derive from if clauses, but their distributions and meaning are really quite dissimilar. For example, while there is a meaning overlap in (55), there is a divergence in (56):

- 55) a. It would be $\left. \begin{array}{l} \text{unnatural} \\ \text{dreadful} \end{array} \right\}$ for a woman to do that.
 b. I would be $\left. \begin{array}{l} \text{unnatural} \\ \text{dreadful} \end{array} \right\}$ if a woman did that.
- 56) a. I don't believe that Mary did that: it is $\left. \begin{array}{l} \text{unnatural} \\ \text{dreadful} \end{array} \right\}$ for a woman to do such a thing.
 b. #I don't believe that Mary did that: it is $\left. \begin{array}{l} \text{unnatural} \\ \text{dreadful} \end{array} \right\}$ if a woman $\left. \begin{array}{l} \text{does} \\ \text{should do} \\ \text{did} \end{array} \right\}$ such a thing.

It is better to accept that for is basic, and that the for complement's inherent meaning combines with various predicates to yield desiderative or hypothetical readings just as the WH complement combines with various predicates and auxiliaries to yield interrogative or dubitative readings.

This semantic description of for may account for the example mentioned in Chapter 1:

- 57) a. That John eats cabbage means that he is
of low birth.
- b. #For John to eat cabbage means that he is
of low birth.

Recall that predicates which imply objective knowledge of truth value are semantically incompatible with the intentional complement. Thus the oddness of (57b) can be explained by observing that the subject complement of verbs like mean, prove, imply, entail is factive: note that under negation (57a) preserves truth value of subject:

- 58) That John eats cabbage doesn't mean that he is
of low birth.

However, under a suitable modal operator, the subject may be regarded as only hypothetically true, the for complement becomes acceptable, and factivity is lost:

- 59) For John to eat cabbage would mean that he is
of low birth.

Finally, it should be pointed out that while the for

complement may describe something hypothetical or unrealized, it may also describe something realized (as in (46)):

60) He's crazy to have done that.

It was crazy for him to say that.

I'm surprised to see you here.

It was totally unjustified for you to fire her.

I was so relieved to see your face when you came in.

When we recall that the for complement, unlike the that complement, is pervious to external time quantification (cf. the discussion of examples (27)ff. above), it does not seem surprising that a for complement may be subject to a kind of temporal instantiation: the cause or reason for an emotive reaction cannot follow that reaction temporally; hence, when the predicate is "dated" or fixed in present or past time, the for complement may also be dated (i.e., describe a realized situation). Compare

61) a. It would offend him for men to act weak.

[= it would offend him if men acted weak]

b. It offends him for men to act weak.

[= it offends him whenever men act weak]

c. It offended him for those men to act weak.

[= it offended him when those men acted weak]

d. It offends him [for him] to see you here.

[= seeing you here offends him]

In summary, rather than derive these various uses of the

for-complement from different paraphrase-sources, such as if, when, -ing, that, that + subjunctive, I propose that all the readings come from the inherent intentional meaning of the for complement interacting with contextual semantic factors such as the governing predicate, modality, and time. The advantages of explaining the essential unity of meaning of for as well as its systematic syntactic distribution are not to be lightly dismissed.⁵

Having established the distinct meanings of the main complementizers, we can conclude again that complementizers exist in deep structure: they are no more to be transformationally introduced than the modals. The phrase structure rules for complementation must be enriched accordingly.

I have thus far considered only the main complementizers WH, that, and for, which occur in predicate complementation and nominal complementation. In Chapter 5 I will argue that the inventory of English complementizers should be extended to those particles introducing comparative and relative clauses -- than, as, that, for. At this point, however, our results can be applied to two problems about relative clauses, once we assume that they are introduced by the complementizers.

Relative clauses can be prefixed by that or for:

- 62) a. She's looking for a pen that we can calligraph with.
- b. She's looking for a pen for us to calligraph with (just to keep herself busy).

(I have added a purpose-infinitive to (62b) to keep it obviously distinct from the infinitival relative.) Both that and for relatives permit the preposing of a relative pronoun under varying conditions:

- 63) a. She's looking for a pen with which we can calligraph.
- b. She's looking for a pen with which to calligraph (just to keep herself busy).

(Notice that the purpose-infinitive does not allow relative preposing: compare She's looking for it just to keep herself busy and *She's looking for it with which to calligraph.)

There is, however, an unexplained phenomenon noticed by Robert Fiengo: only certain main verbs are compatible with an object bearing a for relative clause; compare (62) - (63) with (64) - (66):

- 64) a. She's playing with a pen that we can calligraph with.
- b. #She's playing with a pen for us to calligraph with.
- 65) a. She's filling a pen with which we can calligraph.
- b. #She's filling a pen with which to calligraph.

66) a. She's standing on a pen with which we can calligraph.

b. #She's standing on a pen with which to calligraph.

Verbs which allow an object characterized by a for relative include need, want, search for; those which disallow it include burn, break, trip over, and in general any verbs which imply a concrete or physical relationship between subject and object.

Much more research must be done on this phenomenon, but even at this point we can remark that the class of verbs taking a for-relativized object prominently includes many so-called "intentional" verbs -- verbs which do not imply the existence of their objects or whose objects are in some sense unspecified or indeterminate. (See Anscombe 1965.) To say "I needed a pen" is not to imply that there was some particular pen needed; but to say "I broke a pen" does imply that there was some particular pen broken. Any relative clause describes or characterizes its head, but the relative clauses prefixed by for, the "intentional" complementizer, are peculiarly suited for characterizing intentional objects. There are also intentional subjects:
Tools for you to work with are {available.}
 {#rusty}

One might ask whether it is not an underlying purposive preposition for which accounts for the phenomena in (62) -

(66) rather than the for complementizer itself. The answer is no. While the for preposition may very well underlie (62b) (i.e., a pen [for [for us to calligraph with]]), its presence by itself would not explain the phenomena: consider

- 67) a. I $\left\{ \begin{array}{l} \text{need} \\ \text{broke} \end{array} \right\}$ an instrument for measuring blood pressure.
- b. I $\left\{ \begin{array}{l} \text{need} \\ \text{broke} \end{array} \right\}$ an instrument to measure blood pressure with.

(67a) shows that the preposition for without the for complement does not make the same discrimination between intentional and non-intentional objects as the for complement.

I conclude that the for complementizer has a distinct semantic function which may account for many of the peculiarities of its distribution, even in relative clauses. The second problem to which we may apply our semantic analysis of the complementizers is this: granted that for and that both introduce relative clauses, why is WH precluded from this use? If WH, that, and for are syntactically parallel, as I have argued in Chapter 1, it seems puzzling that English should not have such constructions as those in (68):

- 68) She's looking for a pen whether we can calligraph with.
You saw a boy who else could have have done it.

A woman who I met where shouted at me.

People if are smart don't come here.

The games whether people play are dubious.

It might be possible to devise a syntactic explanation for this gap. Yet the answer is obvious when we consider the semantic function of the relative clause. Relative clauses provide a description or characterization which serves to delimit the reference of a term (noun or pronoun). That and for clauses are available for definitized or intentional descriptions. However, the WH clause is semantically similar to an open sentence. Thus a relative clause construction consisting of a head bound to a WH clause is as semantically incomplete as an expression like "A number n such that n is divisible by ____".

FOOTNOTES

CHAPTER 2

1. Subject-auxiliary inversion can occur in both disjuncts of such questions: Did John come or did Mary leave?
This suggests that WH affects both parts of a coordinate structure in a parallel way, i.e., we have WH(either...or...) = WH(either)... WH(or).... A similar distributivity may occur with and: When and where will I see you?; When will I see you, and where? vs. *When and there will I see you?; *When will I see you, and there?

2. Haj Ross has brought to my attention the problem of "conjunctive questions", which he has investigated in some detail. He has established a number of criteria which distinguish "conjunctive questions" from "disjunctive questions" (or what I call WH complements). Examples of the former are

I can't believe how foolish he is.

Who did what will amaze you.

Observe that believe and amaze disallow whether and if complements (as Ross has noted). A further difference not remarked by Ross is the possibility of

I can't believe what a fool he is.

There is no WH complement (disjunctive question) having this form: e.g.,

*She asked what a fool he was.

I feel that the term "conjunctive question" is a misnomer: it appears to me that the underscored parts of the above examples are exclamatory complements, and ought to be related to such unembedded exclamations as

How foolish he is!

What a fool he is!

(Of course, the oddness of Who did what! must be explained.)

I have not analyzed this construction, but I conjecture that Question Formation is not involved: note the absence of Subject-auxiliary inversion. Possible steps in a derivation might be

He is such a fool! →

?Such a fool he is! →

What a fool he is!

3. It has been suggested that (31b) and (32b) (under the interpretation in question) could be derived from sources like "For an elephant to be in the living room is always odd/would be odd," on the grounds that number agreement doesn't hold: Two elephants in the living room is always odd. However, this solution to the number agreement anomaly cannot be maintained in general; for example, we have 5 days is a long time but no sentential subject source (*For there to be 5 days is a long time). Rather than

hypothesize a sentential source for these subjects, I would guess that numbers and other quantity elements (the "QP's of Chapter 5) are systematically ambiguous, referring either to cardinality (5 days is a long time) or plurality (5 days were spent arguing). That the "indefinite article" an shares this ambiguity with 2, 5, and many would follow at once from Perlmutter's analysis (1970) of an as a reduced form of the number one.

4. Jespersen notes that a similar development has taken place in Norwegian (MEG V:314).
5. In my development of the semantic function of for, I have benefitted from Karin Aijmer's astute observations in her doctoral dissertation (Aijmer 1972), the first draft of which she kindly made available to me. I encourage the reader to examine her account, which differs in many respects from mine, and offers more.

CHAPTER 3

THE ROLE OF THE COMPLEMENTIZER
IN INFINITIVAL PREDICATE COMPLEMENTATION

Near the end of the preceding chapter I asserted that the for complementizer has been over-extended as an analytic device for deriving infinitives. My discussion of the semantic function of for presupposed that true for complements could be syntactically distinguished from other infinitival complements. Here I will justify that assumption. In Section A I investigate the effect of complementizers on the subjects of their complements. A general constraint is proposed which is applied in later sections to the analysis of various kinds of infinitival complement constructions, in (B) to the so-called "nominative and infinitive" and in (C) to the "accusative and infinitive".

A) The Fixed Subject Constraint

In this section I will discuss the following constraint on English movement rules:

- 1) The Fixed Subject Constraint (F.S.C.) (preliminary version)

No NP can be crossed over an adjacent complementizer:

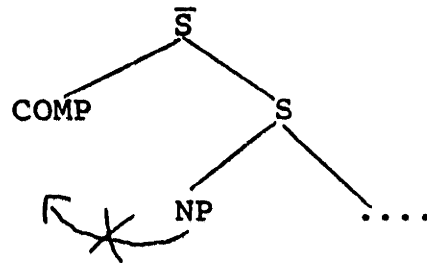

This constraint accounts for a number of restrictions on movement rules in English. First we have (2) vs. (3):

- 2) a. You believe that someone fired on you.
 b. *Who do you believe that ____ fired on you?
- 3) a. You believe someone fired on you.
 b. Who do you believe fired on you?

The subject of the that complement can be questioned (i.e., moved by the Question Formation transformation) only when that is absent. A noun phrase other than the subject is not so constrained: What does he believe (that) you did?

Next, for those verbs which have obligatorily present complementizers, it is not possible at all to question the subject of the complement:

- 4) a. He has asked that we go with him.
 b. *Which of us has he asked that ____ go with him?
- 5) a. *He has asked we go with him.
 b. *Which of us has he asked go with him?

Again, a non-subject can be extracted: What did he ask that we do?¹

Facts parallel to (2) and (3) exist with the for complementizer, although the distribution of for differs somewhat

from that. For is usually either obligatorily present or necessarily absent: few predicates permit an option parallel to (2a-3a). A possible exception is the verb like; some speakers accept both I'd like for you to accompany me and I'd like you to accompany me, giving us the following paradigm (cf. (2)-(3)):

- 6) a. You'd like for someone to accompany you.
 b. *Who(m) would you like for ____ to accompany you?
- 7) a. You'd like someone to accompany you.
 b. Who(m) would you like to accompany you?

(Note also that *For whom would you like to accompany you is bad; for is here a complementizer and not an ordinary preposition.) By contrast, an object can be extracted: What would you like (for) me to do?

Furthermore, there are predicates requiring the presence of for (mostly adjectives and verbs followed by objects, e.g., illegal, surprises me), and these never permit extraction of the embedded subject:

- 8) a. It's illegal for some buildings to be occupied.
 b. *Which buildings is it illegal for ____ to be occupied?
- 9) a. *It's illegal some buildings to be occupied.
 b. *Which buildings is it illegal to be occupied?

(Again note the ungrammaticality of *For which buildings is it illegal to be occupied?) Of course, extraction of

other items is quite acceptable:

10) Which buildings is it illegal for people to occupy?

11) In which buildings is it illegal for meetings to be held?

Additional evidence may be found in a class of predicates which allow a for complement embedded within a prepositional phrase, e.g., hope for, long for, be ashamed of, be afraid of (as noted by Rosenbaum 1967). The preposition, which deletes in front of the complementizer, nevertheless seems to protect the complementizer itself from deletion:

12) a. John would be ashamed $\left. \begin{array}{l} *of \\ for \end{array} \right\}$ us to see him.

b. What John would be ashamed of would be for us to see him.

c. *What John would be ashamed would be for us to see him.

13) a. He longs $\left\{ \begin{array}{l} for \\ * \emptyset \end{array} \right\}$ us to see his real nature.

b. What he longs for is for us to see his real nature.

c. *What he longs is for us to see his real nature.

In (12a, 13a) we see that the complementizer for is required after the predicate. In (12b, 13b) we observe the presence of the underlying preposition when it is separated from the complementizer, in which case the preposition is not deletable (12c, 13c). For these predicates, as predicted by the F.S.C., it is impossible to question the embedded subject:

- 14) a. *Which one of us would John be ashamed for _____
to see him?
- b. *Which one of us would John be ashamed to
see him?

(Cf. *For which one of us is John ashamed to see him?)

Again, this restriction applies to the subject only:

- 15) What would John be ashamed for us to see?

A contrast to (8), (9), and (14) is provided by those cases where for regularly deletes when contiguous to the verb: these do allow extraction of the subject, in accordance with the F.S.C.:

- 16) a. She wants one of her sisters to win.
- b. Which one of her sisters does she want to win?

The intervention of an adverb requires the presence of for:²

- 17) a. She wants more than anything else for one of
her sisters to win.
- b. *She wants more than anything else one of her
sisters to win.

In sum, the F.S.C. applies to both that and for. In the case of WH, extraction is already severely restricted: it is in general impossible to extract anything from a WH complement, except perhaps for the exceptional infinitival ones (What do you know how to do?), and in these, the subject has been deleted. (See Chapter 1, Section C.)

Therefore, we cannot test the proposed constraint against this complementizer.

However, examples of relativization into a WH clause are given by R. A. Hudson (1972). Though such examples seem to me to be marginal, at best, he assesses them as follows:

- 18) a. The book that the editor asked whether I'd review for him was very long.
 b. *The book that the editor asked whether could be reviewed by next month was far too long.

His judgments support the F.S.C.: where the subject has been crossed over an adjacent COMP (18b), the sentence is ungrammatical; where an object has been moved (18a), the sentence is less bad.

Hudson also gives the examples

- 19) a. Many friends though he had, no one came to see him in the hospital.
 b. *Many people though came to see him, he hasn't really many friends.

If though were a COMP, this too would follow immediately from the F.S.C. (Hudson refers to though and the COMP that as "conjunctions"). However, there is reason to suppose that (19) is not a F.S.C. phenomenon. Note that if the movement rule resulting in (19a) mentioned that only part of a VP could be inverted, (19b) could not arise. But such seems to be the case: the VP, short of the auxiliary,

is inverted in Try to hide it though you might..., Foolish as he was, he still.... Because possessive have is treated sometimes as an auxiliary (e.g., Have you many friends?), the VP-shifting rule could derive (19a).

Of much interest are the two possible explanations Hudson considers for these phenomena. First, he argues convincingly against a suggestion by Langendoen (1970) that if that occurred next to the site of a removed subject, it might be construed as the "relative pronoun" that and mistaken for the subject, as in The people that I know that are coming...; here, the phrase might be read as a head (people) modified by two relative clauses (that I know; that are coming). Langendoen's proposal is that a restriction against that followed by a deleted subject is necessary to avoid such ambiguities. Hudson points out that such ambiguities are not common and that the restriction applies even where there is no possibility of ambiguity (as in He's telling a story which I don't think (*that) will ever end). He further objects that analogous ambiguities are permitted when an object rather than subject is relativized (as in The story he told the interviewer (that) he preferred was X: here that he preferred could be a that-complement to tell, a relative clause modifying interviewer, or a second relative clause modifying story; deletion of that still leaves the first two readings). But Hudson's main objection to Langendoen's account is that

it is insufficiently general to account for (18)-(19).

The examples to be given in this section together with those already given buttress this objection and show conclusively that "avoidance of ambiguity" cannot explain the phenomenon accounted for by the F.S.C.

Second, Hudson advances an explanation of his own (p. 117):

"if a clause contains among its immediate constituents both a conjunction (which must be overt) and a grammatical subject, then they must come in that order, even if the subject has been 'raised' into the structure of the matrix clause."

He shows how this proposal explains (18)-(19) as well as Langendoen's examples, and then concludes (p. 118):

If my suggestion is correct, then it looks as though this restriction will have to be treated as yet another "surface" constraint on the output of a set of generative rules (Perlmutter 1970). Moreover, it seems to be a "global" rule (Lakoff 1970), since at the (presumably very late) stage in derivation at which it is determined whether that is present or absent it is necessary to know whether or not some NP on the left of it used to be nondeep subject of its clause. This kind of rule seems to raise considerable theoretical problems for transformational generative grammars (though not, incidentally, for systematic ones -- see Hudson 1971).

Note that the apparent effect of Hudson's surface structure constraint is to prohibit a movement rule from displacing a subject across its adjacent complementizer; thus, in many cases it will duplicate the F.S.C. However, it crucially differs from the F.S.C. in that it requires simultaneous reference to surface structure and some earlier stage in a

derivation: while the F.S.C. prohibits certain rule applications, Hudson's constraint prohibits certain surface results of rule applications. The difference between the two constraints would show up crucially in the following type of case: a rule moves a subject across the adjacent complementizer, but the subject is deleted from its resultant position by later transformations. Hudson's constraint could not rule such a case out, but the F.S.C. could. The following examples provide just such a case. First observe that a duplicated questioned phrase may be deleted:

20) Answer one of these questions: Which candidate do you think you'll vote for, or which candidate does your husband think that he'll vote for?

21) Answer one of these questions: Which candidate do you think you'll vote for, or does your husband think that he'll vote for?

In (21), the second occurrence of which candidate has been deleted. In (23), a similar deletion does not affect the ungrammaticality, contrary to Hudson's constraint:

22) *Answer one of these questions: Which candidate do you think will help you most, or which candidate does your husband think that will help him most?

23) *Answer one of these questions: Which candidate do you think will help you most, or does your husband think that will help him most?

It is the F.S.C. which correctly predicts the ungrammaticality of (23).

There is another indication that it is the movement of a subject across an adjacent COMP which is prohibited and not merely the surface ordering of subject and COMP. Observe that Equi-NP deletion -- which is not a movement rule -- can delete a subject adjacent to a for COMP, but the for must be subsequently deleted:

- 24) a. I hope for you to help me.
 b. *I hope for me to help myself \Rightarrow EQUI
 c. *I hope for to help myself \Rightarrow for deletion
 d. I hope to help myself.
- 25) a. I'd be ashamed for you to find me in such a position.
 b. *I'd be ashamed for me to find myself in such a position \Rightarrow EQUI
 c. *I'd be ashamed for to find myself in such a position \Rightarrow for deletion
 d. I'd be ashamed to find myself in such a position.

(The reflexive in the complement matches the person and number of the deleted pronoun.) Since the for complementizer is normally obligatory in these cases, (*I hope you to help me, *I'd be ashamed you to see me now), we can assume that a special rule deletes for when the subject is absent. But the effect of the for-deletion rule is to obliterate information essential to Hudson's surface structure constraint: thus that constraint could not correctly distinguish between the following cases, for in

none of them is the "conjunction" for "overt":

- 26) a. Who do you want to visit you?
 b. *Who do you hope to visit you?
- 27) a. Who would you invite to visit you?
 b. *Who would you be ashamed to visit you?

By contrast, the F.S.C. makes the correct predictions, for only in the (b) cases of (26) and (27) has a movement across an adjacent COMP occurred --

- 28) a. ↑ You want who to visit you. (source of (26a))
 b. ↑ You hope for who to visit you. (Source of (26b))
- 29) a. ↑ You would invite who to visit you. (source of (27a))
 b. ↑ You would be ashamed for who to see you. (source of (27b))

No matter if the COMP is subsequently deleted, a violation of the F.S.C. has still occurred.

In addition to Langendoen's and Hudson's proposals, yet another attempt has been made to account for the F.S.C. phenomena. This is a surface structure constraint proposed by Perlmutter (1971:100):

30) Surface Structure Constraint (Perlmutter)

Any sentence other than an Imperative in which there is an S that does not contain a subject in surface structure is ungrammatical.

Perlmutter's constraint depends upon a number of special assumptions about "pruning" -- that is, deleting S nodes

from derived structures. (See Perlmutter 1971:Ch.4, n.12). He himself notes (n.16, Ch. 4) some inconsistencies in the criteria for pruning and some difficulties in "ordering" it with respect to transformations. It must be observed that to account for (2) and (3), Perlmutter's constraint requires that in sentences like (2a, 3a), only the former (You believe that someone fired on you) contains an embedded S, the S node being "pruned" from the latter (You believe someone fired on you) because the complementizer is missing. (See Perlmutter 1971:114.) Constraint (30) assumes that the presence of a complementizer implies the existence of an unpruned S even if the subject of the S is absent. I will not discuss whether the particular assumptions about pruning are correct, for in any case, there are other serious problems with constraint (30).

One immediate problem is that Perlmutter's constraint (30), like Hudson's constraint, fails to explain the differences between the (a) and (b) cases of (26) and (27): yet these differences are clearly related to the phenomena in (28) and (29) and hence to other examples Perlmutter seeks to explain (such as (2) and (3)). Thus, surface structure constraint (30) is insufficiently general.

Another defect in generality is that Perlmutter's constraint requires the complementizer that to be distinguished from a "relative pronoun" that which must function as the

"subject" of the underscored clause in cases like (31):

- 31) Machines that can add have been used for thousands of years.

(Hudson, incidentally, accepts that the relative that is a "conjunction".) If that in (31) turned out to be a complementizer, as I argue in Chapter 5, (31) would be ruled ungrammatical by constraint (30). Yet if that plays the role of subject in (31), what of as in (32) or than in (33)?

- 32) He goes on doing such things as are expected of a young man in his position.

- 33) He offers more than could be expected.

Jespersen, having noted the syntactic similarity of that, as, and than in these uses, (MEG III.8, p. 169) observed,

Nothing is gained in such cases by putting up fictitious subjects and objects [i.e., as, than that as "relative pronouns" -- J.W.B.]: it is much better to face the simple truth that there are clauses without a subject and others without an object, just as there are sentences without either.

While (30) lacks generality in failing to discriminate between (26) and (27) and in requiring two kinds of that particles to preserve (31), there are ways in which it is "too general". For example, it would rule out (32) and (33) as ungrammatical, unless as and than were considered to be "pronouns". In fact, it would rule ungrammatical all of the following sentences: their underscored clauses lack surface structure subjects but contain

particles which imply the presence of an unpruned S:

- 34) Mary wondered whether to disqualify herself if a conflict arose.
- 35) As many students were flunked as were passed.
- 36) He says that more people will acquiesce to tyranny than will fight it.
- 37) All that can be said for him is that he seldom beats his wife.
- 38) Susan was bitter, but was bitter with good reason.
- 39) The patient was weak, and if we are to believe his doctor, could hardly sip tea.
- 40) As usually happens, the criminal got away.
(Jesp. AS 23.5)
- 41) He died, as was predicted by the fortune-teller.

I will not argue in great detail that each of these examples contains an unpruned S. It is sufficient to observe the following. (34) contains an ordinary WH complement which lacks a subject but contains a conditional clause and a complementizer. The conditional clause may be dominated by the (unpruned) embedded S, as in Mary wondered whether, if a conflict arose, to disqualify herself. (35) and (36) show extraposition of as and than clauses; the rule removing the subjects doubtless applies before the extraposition, exactly as in A speech was given that excited everyone. But, and this is important to note, it is presumably an S [\bar{S} , on my analysis] which is extraposed.

The other cases are also clearly clauses; in particular, the but clause in (38) should be analyzed as an S by its intonation and the fact that it easily allows the interpolation of parentheticals. Contrast (38) to Susan was bitter but proud: it would be perverse to argue that the phrase but proud was an S. (E.g., ?Susan was bitter but, as it turned out, proud.) But the very reasons for refusing it sentential status would tend to distinguish it from the conjunct in (38). (E.g., Susan was bitter but, as it turned out, was bitter with good reason.) As for (37), if that is a pronoun, it is unlike any other, for all by itself cannot be the antecedent of an anaphoric pronoun: *all₁ which₁ I could do; *Pete told all₁, and Mary told it₁, too.

While the above examples would be ruled ungrammatical by Perlmutter's constraint (30), they are permitted by the Fixed Subject Constraint (1), because in none of them has the missing subject been crossed over an adjacent complementizer. In (34) the subject of disqualify is deleted by Equi-NP Deletion (see Chapter 1). In (35)-(36), comparative formation applies and in (37) relative clause formation applies: but neither process crosses an element over the comparative or relative complements (the ones adjacent to the head). In (38)-(41) there is no evidence of cross-complementizer movement, or any movement at all.³

Sentences (34)-(41) are therefore crucial evidence in favor of the Fixed Subject Constraint (1) over the surface structure constraint (30).

The essential reason that Perlmutter's constraint (30) is too "general", or too strong, is that it does not distinguish between deletion and movement rules. But this is a necessary feature of Perlmutter's account, for he is attempting to relate three phenomena, (i) the impossibility of moving the subject out of a complement clause (over a COMP) (e.g., (2) and (3)); (ii) the impossibility of subject pronoun deletion in S's; and (iii) the existence of expletive subjects in S's, (e.g., the it in It's getting late). Perlmutter's insight is that if a language exhibits (i), then it will exhibit (ii) and (iii), although he claims that the converse does not hold. A language is a "Type A" language, in Perlmutter's terminology, if and only if it exhibits (i). All and only Type A languages are subject to surface structure constraint (30).

But we have seen that, by Perlmutter's criterion, English is a Type A language; hence it should be subject to constraint (30). Nevertheless, not every English clause has a subject in surface structure. Exactly the correct discriminations, however, are made by the F.S.C., so we must conclude that phenomena (i)-(iii) are not related by a surface structure constraint. Some other explanation must

be found for the relation of (i)-(iii) in Type A languages, if indeed it is a valid typological generalization.

It may well be true that no language which has the F.S.C. can allow free deletion of nonemphatic subject pronouns. "Free deletion" may be distinguished from "bound deletion": the latter is deletion under identity, as in Equi-NP Deletion in English, while the former is deletion unconstrained by such particular conditions, as in Spanish subject pronoun deletion.⁴ This distinction may allow us to express Perlmutter's observation that (i) \Rightarrow (ii):

42) The Free Deletion Constraint

No language which is subject to the Fixed Subject Constraint can allow free deletion of subject pronouns.

(42), which is a reformulation of Perlmutter's observation in terms of the F.S.C. rather than the (invalid) surface structure constraint, might be motivated as follows. The F.S.C. does not hold in all languages, particularly in those languages which have free deletion. From the point of view of language acquisition, this restriction makes sense intuitively: if a language subject to the F.S.C. also allowed free deletion of subject pronouns, sentences would appear which seemed to violate the F.S.C. and, indeed, it would be hard to find evidence for the presence of the constraint. In such a hypothetical case, it would be wrong to say "Which ones do you think that were here?" but

right to say "Which ones did you tell that were here?", as well as "Which ones think that were here?" Apparent violations would constantly appear, as in:

43) It means something that it happened yesterday. \Rightarrow

What does it mean that it happened yesterday? \Rightarrow

What does mean that happened yesterday?

44) Mary asked someone whether he was coming. \Rightarrow

Who did Mary ask whether he was coming? \Rightarrow

Who did Mary ask whether was coming?

On the other hand, bound deletion would not so radically undercut the evidential basis for the F.S.C., since bound deletion is highly restricted by the "binding" between the item deleted and the element to which it is "identical" -- the conditions of "control".

If (42) captures the relation (i) \Rightarrow (ii), what about (iii), the existence of expletive subjects in S's? I do not know enough about this phenomenon to venture any speculations. Perlmutter leaves it open whether such dummy subjects are present in deep structure or transformationally inserted. In the former case, constraint (42) does all the work of the surface structure constraint (30) in relating the phenomena. In the latter case, some other explanation must be given. For English, there is evidence that some expletive subjects are transformationally introduced;

these are discussed in the next section. Note, however, that the presence of expletive subjects is not a surface structure matter: English sentences may occur without expletive it in surface structure (It was clear that Linda was onto something big, but wasn't obvious just how big that something was.). Thus, once again, while there may be a valid generalization which will eventually explain the relation between (i)-(iii), the surface structure constraint fails to capture it correctly.

I have argued that the F.S.C. correctly expresses a generalization about English which cannot be explained by means of Langendoen's "ambiguity" proposal, Hudson's global ordering condition, or Perlmutter's surface structure constraint. Some of the counterexamples to Perlmutter's surface structure constraint, namely (32)-(41), are directly attributable to his attempt to relate the F.S.C. phenomena to the non-deletability of subject pronouns. The Free Deletion Constraint (42) expresses this relation without the undesirable side effects of a surface structure constraint.

I should mention here that Perlmutter gives one argument (pp. 111-112) against explaining the F.S.C. phenomena by means of a condition on transformations, and in favor of doing it by means of a surface structure constraint.

Consider (45):

- 45) a. *John is anxious for someone to visit him, but
I don't know who John is anxious (for) to
visit him. \Rightarrow
- b. John is anxious for someone to visit him, but
I don't know who.

Assuming that (b) derives from (a) by means of Sluicing (Ross 1969), Perlmutter argues, essentially, that if (45a) is ruled out by a constraint on transformations rather than a surface structure constraint, (45b) should also be ungrammatical: in other words, a violation of the F.S.C. occurs in the derivation of (45b), but in its surface structure there is nothing to violate constraint (38). However, it is well known that other violations of constraints on transformations are mitigated by the Sluicing transformation -- indeed, this was one of Ross's points. Consider (46):

- 46) a. *Press aides revealed that the President would
make a surprise proposal to disband a certain
corporation -- which corporation the President
would make a surprise proposal to disband they
didn't say.
- b. Press aides revealed that the President would
make a surprise proposal to disband a certain
corporation -- which corporation they didn't
say.

In (46a) a violation of the complex NP constraint occurs, but it is not reflected in (46b). As a result, the argument

from Sluicing cannot be applied against the F.S.C.

Though I have given examples only with Question Formation, many other transformational processes are subject to the constraint. (Of course, rules which involve no COMP-crossing, such as Equi-NP Deletion, are not constrained by (1).) Rules which are subject to the constraint, in addition to Question Formation, appear in the following examples:

Relative Clause Formation

- 35) a. The things they believe will happen are disturbing to contemplate.
 b. *The things they believe that ___ will happen are disturbing to contemplate.
- 36) a. The things I want to happen are impossible.
 b. *The things I hope (for) ___ to happen are impossible.

Comparative Formation

- 37) a. You'll suffer worse things than you'd believe were possible.
 b. *You'll suffer worse things than you'd believe that ___ were possible.
- 38) a. Worse things than you'd want to happen to a dog will happen to you.
 b. *Worse things than a masochist would ever hope (for) ___ to happen to him will happen to you.

Topicalization

- 39) a. ¹Jóhn I don't believe will visit me.
 b. *John I don't believe that ___ will visit me.
- 40) a. ¹Jóhn I don't want to visit me.
 b. *John I don't hope (for) ___ to visit me.

Clefting

- 41) a. It's Mary who he doesn't believe will be
 successful.
 b. *It's Mary who he doesn't believe that ___ will
 be successful.
- 42) a. It's Mary who he doesn't want to be successful.
 b. *It's Mary who he doesn't hope (for) to be
 successful.

Pseudo-clefting

- 43) a. What I believe will happen is this.
 b. *What I believe that ___ will happen is this.
- 44) a. What I want to happen is this.
 b. *What I hope (for) ___ to happen is this.

At this point, the question naturally arises whether Comparative Formation and Relative Clause Formation can be regarded as movement rules. In Chapter 5 I argue that these rules are essentially the same process, involving both a movement and a deletion. After discussing those rules, I will reformulate the F.S.C. more precisely.

B) The Source of the Shifting Subject

(i) The Problem

We have seen that the Fixed Subject Constraint limits the application of movement rules affecting subjects in English. Let us now extract some consequences from this constraint.

Syntacticians have agreed that there is some sort of transformational relationship between the following two types of sentence.

- 1) It happens that Mary once killed a man.
- 2) Mary happens to have once killed a man.

There is evidence that (2) is derived from a structure similar to that underlying (1). For example, There insertion does not apply with happen by itself as a main verb, but requires a form of be:

- 3) a. Such things happen.
b. *There happen such things.
- 4) a. Such things are happening all over.
b. There are such things happening all over.

Nevertheless, we find there in examples like (5):

- 5) There happens to be a meeting going on.

Furthermore, the conditions under which there can appear as the subject of happen exactly reflect the conditions under which it can appear in sentences like (6):

- 6) It happens that there is a meeting going on.

Thus, the examples in (7) are ungrammatical because they violate the conditions for there insertion shown in (8):

- 7) a. *There happens to be it going on.
 b. *There happens to have died a man.
- 8) a. *It happens that there is it going on.
 b. *It happens that there has died a man.

As linguists have observed, the relations between (5) and (6), (7), and (8) can be explained by postulating a transformation to derive (2) from something like (1). Such a transformation would also explain the rough synonymy between (9) and (10):

- 9) The counselor happened to ignore poor students.
 10) Poor students happened to be ignored by the counselor. (from Kajita, 1967)

Compare (9) and (10) to (11) and (12):

- 11) The counselor wanted to ignore poor students.
 12) Poor students wanted to be ignored by the counselor.

While (9) is true if and only if (10) is true, (11) and (12) are independent in truth value. The synonymy of (9) and (10) could be explained by deriving both from the structure underlying It happened that the counselor ignored poor students: if the embedded complement is passivized, (10) will result; if not, (9) will result. (11) could not have a comparable derivation (*It wanted that...).

Various accounts of the transformational relation between (1) and (2) have been given. Rosenbaum's derivation (1967) may be summarized in the following diagrams:

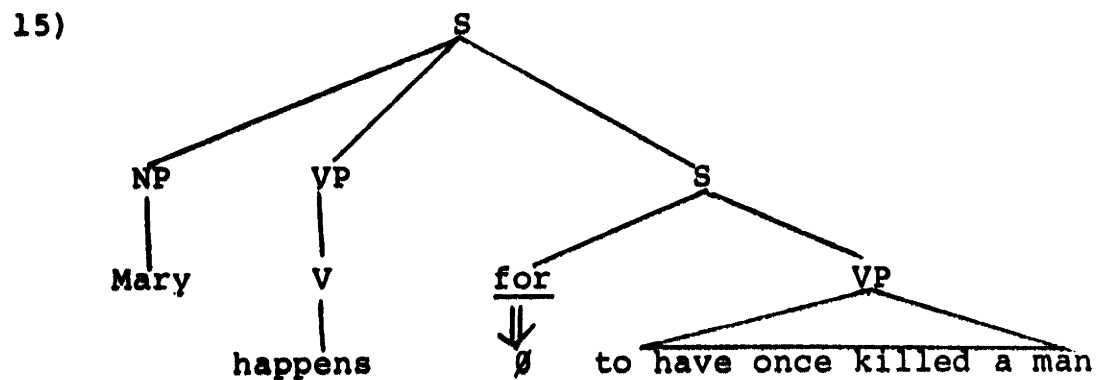
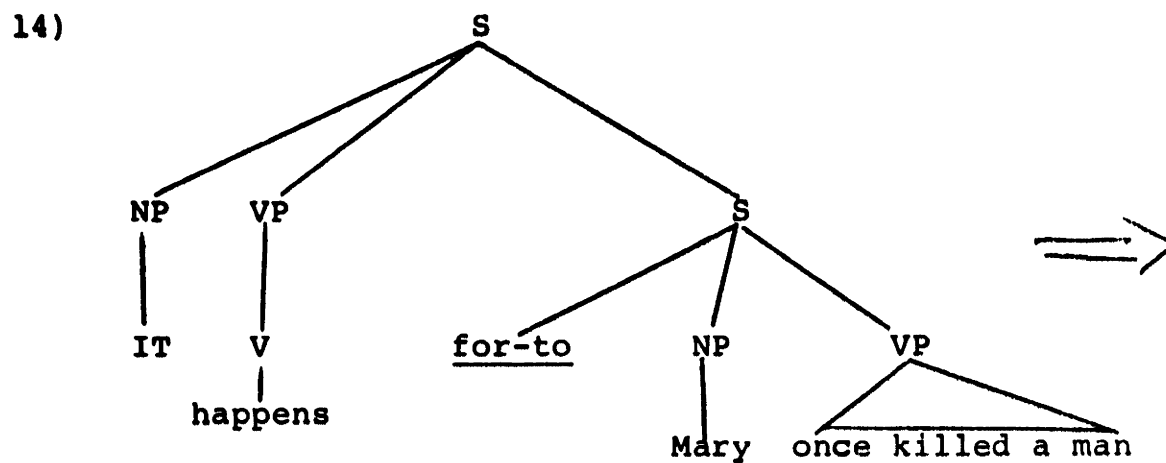
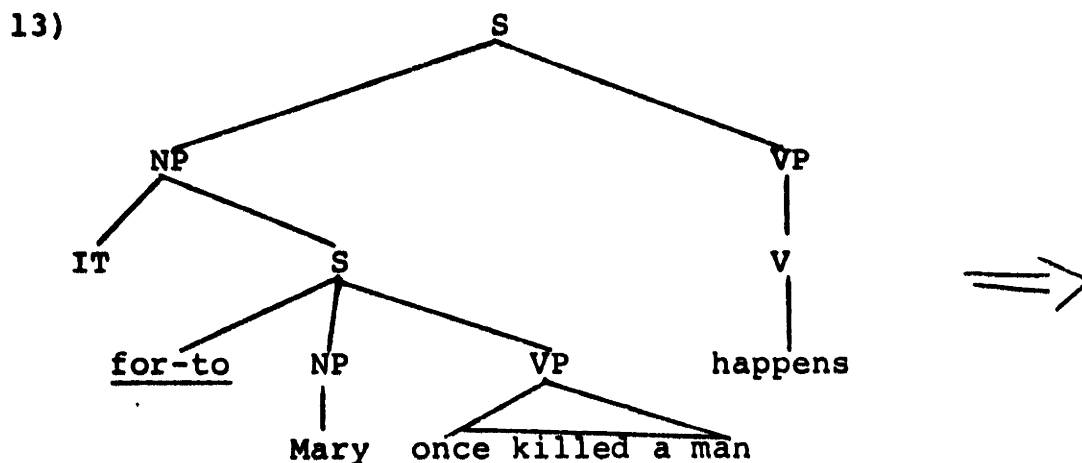

Step (14) is extraposition of the clause and step (15) is called Pro Substitution or It Replacement. Variants of this analysis combine steps (14) and (15) into one rule (e.g., R. Lakoff 1968). But what is essential to all these analyses is the postulation of a sentential subject (as in (13)) from which the surface subject is shifted to yield structures like (15).

The analysis shown in (13)-(15) and its variants are certainly sufficient as a first approximation, and they do provide a useful model for grasping the essential relations in sentences like Mary happens to have once killed a man. However, in many ways they are inadequate. One problem is that happen does not share certain properties of predicates having sentential subjects; compare happen to be obvious:

- 16) a. *That Mary is quite tall happens.
- b. That Mary is quite tall is obvious.
- 17) a. Mary happens to be quite tall.
- b. *Mary is obvious to be quite tall.
- 18) a. *What happens is that Mary is quite tall.
- b. What is obvious is that Mary is quite tall.

Especially curious is the ungrammaticality of the Pseudo-cleft form (18a): happen cannot merely be marked as an exception to that rule, because as we saw above happen + infinitive permits pseudo-clefting (e.g., What happened to advance his career was his skill at croquet). To complicate

things, there is another sense of "happen", meaning "to take place", which does allow such a pseudo-cleft, at least for some people:

- 19) a. When you flip this switch, what will happen first is that the blades will retract.
- b. What was happening across the country was that the women were throwing off the bonds of feudal servitude.

But this sense of happen does not seem to allow It Replacement:

- 20) a. *When you flip this switch, the blades will happen first to retract.
- b. *The women were happening across the country to be throwing off the bonds of feudal servitude.

There are also theoretical difficulties with the analysis summarized in (13)-(15), namely, (i) the assumption that for underlies the infinitive, (ii) the lack of an explanation for the conditions under which the transformation(s) will apply, (iii) the violation of the Fixed Subject Constraint caused by the movement of the subject.

(i) The problem of accounting for the infinitive in (2) results from the principle "Where to appears, for was there." Rosenbaum, R. Lakoff, and Kajita each assume that for (-to) is a possible "marker" for the complements of predicates like happen, although for does not show up in

these cases even under conditions in which it is normally obligatory:

21) *It happens, unfortunately, for Mary to be too tall.

22) *For Mary to be too tall happens.

Thus, if the infinitive in (2) is to be derived from a for complement, it is necessary to make the transformations of (13)-(15) both dependent on the presence of for and obligatory.

(ii) Even if the sequence (13)-(15) is obligatory and depends on the presence of for, there are difficult problems in explaining under what conditions the transformation(s) will apply. For example, it doesn't apply in (23):

23) a. It is impossible for John to have done that.

b. *John is impossible to have done that.

In other words, on this analysis, a large amount of transformational irregularity must be assumed.

(iii) Whether the process of deriving (2) from (1) (or a similar structure) occurs in one or two steps, a violation of the Fixed Subject Constraint still occurs when the embedded subject replaces it. If the process is a single step, mapping *For Mary to have once killed a man happens directly into Mary happens to have once killed a man, Mary

is moved from a fixed-subject position, for complementizers are obligatory in sentential subjects (*John is here worries me). On the other hand, if the derivation occurs in two steps, the second step will still violate the constraint. One might think to avoid such a violation by having Pro replacement (14) apply after complementizer deletion, but there is no motivation for extending the latter rule to all cases where Pro replacement occurs. Consider (24) and (25):

- 24) a. It didn't seem to Mary that John was very sick.
 b. *It didn't seem to Mary John was very sick.
 c. John didn't seem to Mary to be very sick.
- 25) a. It never happens that John is here when the dishes need to be washed.
 b. *It never happens John is here when the dishes need to be washed.
 c. John never happens to be here when the dishes need to be washed.

(24) and (25) show that the subject can shift even where a complementizer cannot normally be deleted, thus violating the Fixed Subject Constraint.

The problems just sketched indicate that something is wrong with the analysis given in (15) and its variants. To be sure, there are means of "handling" these problems: verbs and adjectives can be marked as exceptions to the rule(s)

in (13)-(15); another special rule could delete the complementizers in positions where It Replacement is going to take place. But these are stop-gap measures. Still unexplained are the peculiarities in (18)-(20). In the next section I will present an alternative analysis which more adequately explains the characteristic properties of sentences like (2).

(ii) A Solution

Let us begin by examining those verbs which undergo the subject replacement process just considered. (A very valuable study of such verbs is available in Kajita's dissertation, whose classification of verb-types I have greatly benefitted from (Kajita (1967).) The verbs which undergo subject replacement are contained in a larger class of verbs which have been termed "semi-auxiliaries" (Kajita, 1967). The semi-auxiliaries, as their name suggests, share properties of both verbs and such verbal auxiliaries as modals. Unlike ordinary verbs which take infinitival complements (e.g., want, like, believe, suppose), the semi-auxiliaries always require the subject of the complement to be unexpressed (deleted) and understood as identical to their own subjects. Compare the semi-auxiliary in (1) to the verb in (2):

- 1) a. Mary seems to enjoy herself.
b. *Mary seems (for) Carol to enjoy herself.
- 2) a. Mary wants to enjoy herself.
b. Mary wants Carol to enjoy herself.

In this respect, semi-auxiliaries resemble modals: Mary must enjoy herself; *Mary must (for) Carol (to) enjoy herself. But unlike modals, semi-auxiliaries can themselves be used as non-finite verbals, and can themselves take auxiliary modals: She may seem to be enjoying herself vs. *She may can be enjoying herself.

The semi-auxiliaries fall into two major groups -- those which impose selectional restrictions on their (surface) subjects and those which do not. Examples of the former are try, avoid, bother, hasten, serve (Kajita's groups (1) and (2)). Examples of the latter are happen, seem, be likely (Kajita's groups (3)-(7)). I will disregard the former class, because it is only the latter to which the subject replacement transformation applies.

Thus the first major characteristic of the verbs which undergo subject replacement is that they impose no selectional restrictions on their (surface) subjects.

Compare:

- 3) *There tried to be a gun on the shelf.
- 4) **There** happened to be a gun on the shelf.

At first sight it might seem that this fact is explained by the sentential subject analysis ((13)-(15) of section (i)): we have already observed in Chapter 1 that semantic selection does not "go down into" a clause. But the fact is, the overwhelming majority of the verbs under discussion never occur with a subject clause:

- 5) a. That John was sick was {certain }
 {likely } .
- b. ?That John was sick {was sure }
 {happened } .
- c. *That John was sick {was about }
 {failed }
 {came }
 {got }
 {chanced }
 {seemed }
 {turned out }
 {appeared }
 {proved }
 {began }
 {continued }
 {ceased }
 {started }
 {tended }
 {had }
 {was bound }
 {was apt } .

Nevertheless, arguments for a subject shift transformation apply to the verbs in (5b, c), as well as to those in (5a). Table I summarizes the relevant facts.

TABLE I

| | There Insertion | Passive = Active |
|---|--|---|
| sure certain likely bound apt | There is sure to be another snowstorm in March. | The counselors are sure to ignore poor students. Poor students are sure to be ignored by the counselors. |
| turn out prove happen | There turned out to be still another bottle in the closet. | The group turned out to hate champagne. Champagne turned out to be hated by the group. |
| seem appear | There seemed to be few women there. | The women seemed to hate the men. The men seemed to be hated by the women. |
| start begin | There is starting to be a problem in keeping them in line. | The counselors are starting to neglect poor students. Poor students are starting to be neglected by the counselors. |
| continue cease | There has continued to be a problem in this area. | The counselors have continued to neglect poor students. Poor students have continued to be neglected by the counselors. |
| tend | There tended to be few women in those professions. | Many women tended to fear success. Success tended to be feared by many women. |
| have fail | There had to be an explanation for this. | Many women had to find new jobs. New jobs had to be found by many women. |
| about | There is about to be another snowstorm. | They are about to fire him. He is about to be fired by them. |
| come | There is coming to be a new attitude among the young. | The group came to hate champagne. Champagne came to be hated by the group. |
| get | There are getting to be too many of us. | People are getting to hate me. I am getting to be hated by people. |

In short, while there is evidence that the surface subject in the examples of Table I is transformationally shifted from an embedded sentence, there are many difficulties with analyzing that S as a sentential subject. In addition to the problems given in Section A, there is the fact given in (5) that most of the verbs in question resist surface sentential subjects. A further problem to be solved is that none of the verbs occur with for clauses² and not all take that clauses, even when extraposed:

- 6) *It proved that John was sick. (in sense "John proved to be sick")
- | | | | | | |
|---------------|---|---|---|---|--------------------------------------|
| *It began | " | " | " | " | |
| *It continued | " | " | " | " | |
| *It ceased | " | " | " | " | |
| *It started | " | " | " | " | |
| *It tended | " | " | " | " | |
| *It had | " | " | " | " | |
| *It was bound | " | " | " | " | |
| *It was apt | " | " | " | " | (in sense "John was apt to be sick") |
| *It was about | " | " | " | " | |
| *It came | " | " | " | " | |
| *It failed | " | " | " | " | |
| *It got | " | " | " | " | (but: "It got so that...") |

In other words, while Table I gives evidence for an underlying S, many of the verbs show no surface cooccurrence with any of the familiar complement types, whether in subject or extraposed position.

Suppose, then, that the source of the shifting subject is a bare S, unmediated by complementizers -- the "inner S" of the rule $\bar{S} \rightarrow \text{COMP S}$. Because complementizers are obligatory in subject clauses, as we saw in Chapter 1, the

bare S could not be introduced there. (Alternatively, it may be that only \bar{S} is recursive in NP.) Thus the underlying structure for the examples in Table I would look like this:

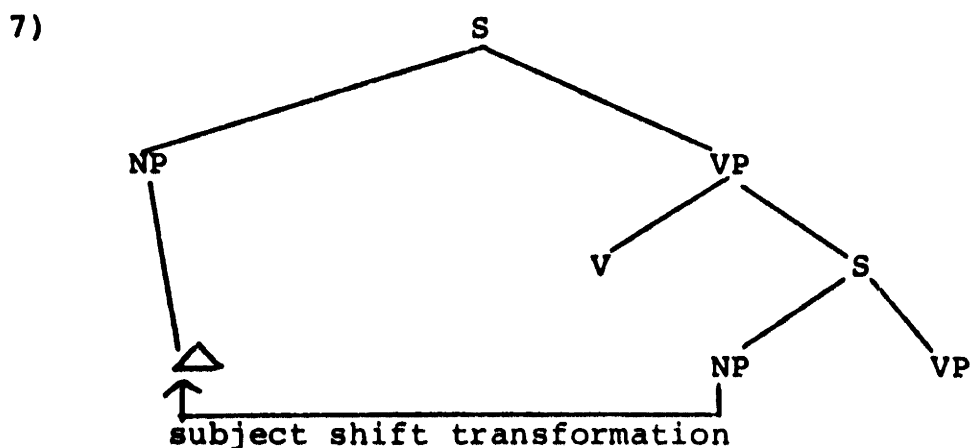

For those verbs which may occupy V in (7) -- the logically subjectless semi-auxiliaries -- this structure accounts for the absence of subject-selection, the impossibility of sentential subjects, the possibility of subject shifting without a violation of the Fixed Subject Constraint, as well as the characteristic properties of Table I: There Insertion and synonymy of active and passive. In addition, it permits us to remove all special restrictions and exceptions from the Subject Shift transformation: it is now an obligatory rule with no exceptions.

All verbs which undergo Subject Shift have the strict subcategorization of (7), but many of them have additional subcategorizations. In contrast to the verbs of (6), the verbs sure, certain, likely, turn out, happen, seem, appear, ?chance may also have that complements:

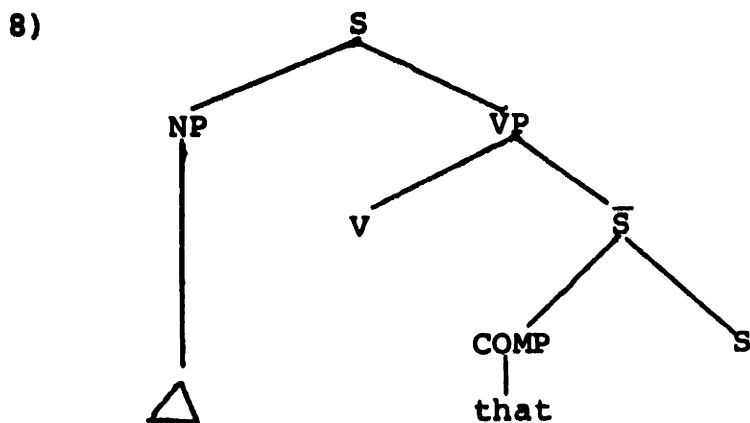

The fixed Subject Constraint prevents the movement of the subject of the embedded S into the matrix subject (COMP deletion is probably ordered as the last rule in S; cf. Part C). Instead, an expletive it is inserted into the subject.

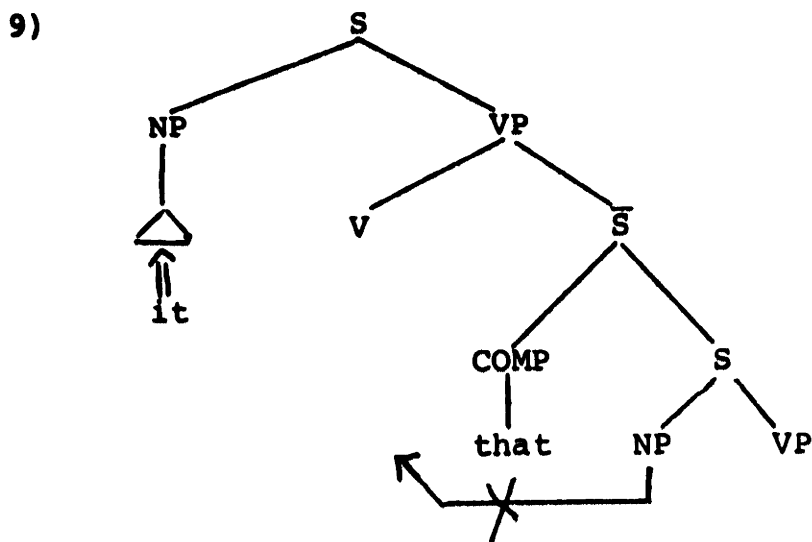

Thus, for example, both seem and tend are logically subjectless semi-auxiliaries, but only seem has the optional alternative of a that complement in addition to the bare S complement. This analysis of verbs like seem accounts for the impossibility of deep structure subjects, sentential or otherwise:

- 10) a. *That Mary is quite tall { seems
appears
happens
turns out } .
- b. That Mary is quite tall pleases me.
- 11) a. *What { seems
happens
appears
turns out } is that Mary is quite tall.
- b. What pleases me is that Mary is quite tall.
- 12) a. *What { seems to you }? *Something { seems to you. }
{ proves
chanced
tends } { proves
chanced
tends }
- b. What pleases you? Something pleases you.

However, a number of these verbs have still other uses (not as semi-auxiliaries) in which they may have logical subjects. Happen, for example, has a purely verbal sense "to take place" as well as its use as a subjectless semi-auxiliary. In the former case, as we saw in example (19), B(i), it may permit pseudo-clefting. The ambiguity between the semi-auxiliary happen and the plain verb happen appears in the following example:

13) Something happened to upset their plans.

(13) may mean "Something happened which had the effect of upsetting their plans." This sense of happened means "took place" or "occurred"; it is consistent with adverbs of occurrence, such as suddenly, and can be used where the semi-auxiliary would not make sense (e.g., example (20), B(i)). The other meaning of (13) is roughly equivalent to "It

happened that something upset their plans", or "Something chanced to upset their plans." The first reading entails that something happened beyond the upsetting of their plans, but the second reading has no such entailment.

If some of the subjectless semi-auxiliaries have other subcategorizations in which a subject is possible, it should not be surprising that a few of them permit sentential subjects. There are, I believe, only two clear cases of this. (See the verbs in (5a).) These verbs, which are unrepresentative of the class of subject-shifting verbs as a whole, are the only ones which lend support to the previous analysis ((13)-(15) in Section (i)).

Aspects of the analysis I have given have appeared in previous work, notably Kajita (1967). (See also Emonds 1970.) But Kajita concludes that only his Group 6 verbs are subjectless in deep structure. Briefly, on Kajita's account, there are four groups among the verbs which undergo subject shift, groups 3-6. Group 3 (including happen, be likely, be certain) permit a sentential subject and would have the analysis of (15) in Section (i). Group 4 (including seem, appear, turn out) have no sentential subjects and are subcategorized for [it__S]. Group 5 (including begin, continue, cease) are assumed to have a sentential subject, which, however, can only appear if nominalized. Group 6 (tend, have, be bound, among others)

are subjectless, with S complements, as in (7) above. All infinitival complements are derived from for-to.

Kajita's account far more closely approximates the behavior of these verbs than previous accounts such as Rosenbaum's. However, his use of for-to and sentential subjects is open to the objections I have already given. Kajita's classification of verbs corresponds to possible subcategorizations, e.g., Group 5 verbs are assigned sentential subjects essentially because they have an intransitive use in addition to their semi-auxiliary use: The concert began, work continued, their fighting ceased. Thus, both their fighting ceased and their fighting ceased to annoy me would come from an underlying intransitive construction. But there is really very little evidence for a sentential subject:

- 14) a. Jokes ceased to amuse them.
 b. *That jokes amused them ceased.
 c. *For jokes to amuse them ceased.
 d. *Jokes' amusing them ceased.
- 15) a. He began to try harder to win.
 b. *That he tried harder to win began.
 c. *For him to try harder to win began.
 d. *His trying harder to win began.

In connection with verbs like cease and begin, one must consider Perlmutter's arguments (Perlmutter 1970b) for the

existence of a source like (15b) for (15a). None of Perlmutter's arguments actually establish that analysis: they show only that the subject of "NP began to VP" must be derived from an S in which NP is the subject of VP. Thus they support the analysis here (8). The one apparent exception is his first argument, that nominalized sentences can occur as the subject of begin:

- 16) [=P's(5)] The doling out of emergency rations
began.

But notice that when nominalizations are used as subjects of intransitive begin, the more "noun-like" ones (the so-called "derived nominals" of Chomsky (1971b)), are far more acceptable than the more "sentence-like" ones (the "gerundive nominals" of Chomsky (1971b)).

- 17) a. Zeke's active work(ing) begins at 3:00.
b. *Zeke's working actively begins at 3:00.

(Cf. also (14d, 15d).) This fact goes against the sentential subject analysis, but is consistent with the analysis I am proposing. It suggests that begin, on one sub-categorization, is an intransitive verb permitting (non-sentential) nominal subjects. But this construction is not the source of the shifting subject; indeed, if it were, one could not explain the ungrammaticality of sentential subjects and gerundive nonlexical nominalizations. (Note that we have here in embryo an argument for Chomsky's lexicalist hypothesis.) Incidentally, the possibility of

(18)

18) Zeke's working (so) actively begins to seem like
a form of ostentation.

is yet another argument that the subject is shifted from
a deep structure position distinct from its surface position.

To summarize, the source of the shifting subject for all
of the verbs considered is (19):

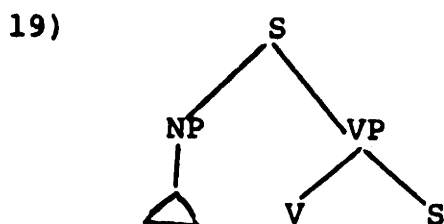

A subset of these verbs can occur in (20) as well as (19):

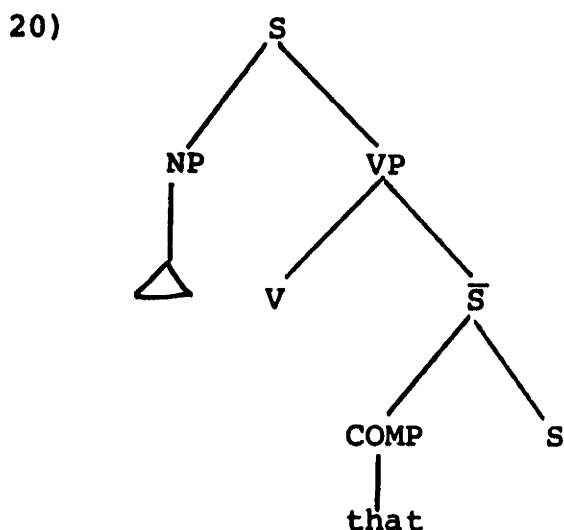

Some few of these verbs (perhaps two) may also occur in
(21), which, however, is not a source of the shifting
subject:

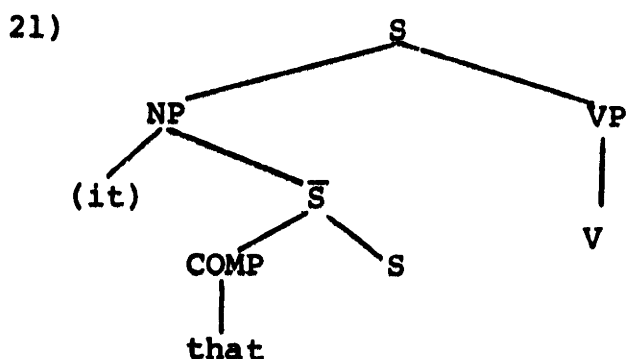

It is important to recognize the evidence for the claim that there is a class of English verbs which are subjectless in deep structure. The postulation of a dummy node " Δ " is not arbitrary, but serves to explain a wide variety of facts. Assuming that in English an empty subject node must be filled at some point in the derivation, the postulated dummy explains why an expletive subject must be inserted in (20), if Subject Shift has not applied. Moreover, it accounts for the impossibility of sentences like *That John isn't here seems, *What seems?, *What seems is that John isn't here. Finally, it explains additional facts which might at first sight appear to be unrelated. Consider the following examples:

- 22) a. More is known than it seems.
 b. *More is known than ___ seems.
- 23) a. *More is known than it is necessary.
 b. More is known than ___ is necessary.

(Facts similar to (22)-(23) were brought to my attention by Will Leben.)

- 24) More is known than ___ seems to be necessary.

The contrast between (22b) and (23b) follows from the fact that in deep structure, seems is subjectless, while is necessary is not. (The contrast between (22a) and (23a) reflects the difference between More is known than it seems is known and *More is known than it is necessary is known.) In (24), Subject Shift has given seems a derived subject, which has been subsequently deleted under Comparative

Formation. Thus the analysis of subjectless semi-auxiliaries simultaneously accounts for a wide range of facts, from the apparent obligatoriness of extraposition to seeming vagaries of Comparative Formation.

Through an application of the Fixed Subject Constraint to the analysis of subjectless semi-auxiliaries like seem, happen, tend, we have seen that in addition to for complements, there is a second source of infinitival S's -- the "bare S" or unmediated complement. We shall see in Section C that the unmediated complement is also one source for the "accusative and infinitive" construction.

(iii) Relation to the Passive

We have seen that there are subjectless verbs in English deep structures. However, there is a rule introducing expletive it into the subject position when it is not otherwise filled. The fact that English has such a rule might be explained by Emonds' hypothesis that an obligatory node must be filled at some point in a derivation, not necessarily surface structure. (Examples (22)-(24) of (ii) show again what was argued in Section A, that a surface structure clause may lack a subject.)

In some languages, however, verbs like seem lack even expletive subjects. If Emonds' hypothesis is taken as a

universal, this implies that in such languages the subject is not obligatory in deep structure, i.e., instead of a phrase structure rule $S \rightarrow NP VP$, there may be languages with $S \rightarrow (NP) VP$. On the other hand, Emonds' hypothesis may not be universally applicable, but contingent upon other factors. There is obviously a close relationship between the Fixed Subject Constraint, Emonds' hypothesis, and Free Deletion. It is an unexplained fact that the subject of an S has a special role in some languages (R. Higgins suggests that these languages may be the ones with heavily fixed word order or little "scrambling"), and this special role is not confined to surface structure. Further research into comparative syntax is needed to answer these questions. Perhaps the Fixed Subject Constraint will be seen to follow from some deeper generalization about English syntax.

One of the possible applications of Emonds' hypothesis would be to explain why passive sentences must have subjects while passive nominals need not:

- 25) a. *Was destroyed the city by the enemy.
 b. the destruction of the city by the enemy
- 26) a. The city was destroyed by the enemy.
 b. the city's destruction by the enemy

In English the subject NP of a sentence is an obligatory node, unlike the object NP's. In other words, if a sentence appears without a subject, an argument can always be

given that there was an underlying subject node. In the case of exceptional verbs like seem the node is unfilled by lexical items in deep structure, but its existence can still be inferred: for example, it is entailed by the structure-preserving hypothesis, which is distinct from the "filling" hypothesis mentioned above; further, the node is necessary to provide the correct derived constituent structure after it insertion has applied, for the it behaves like an NP with respect to other transformations, such as Subject-Auxiliary inversion (Does it seem to you that I'm wrong?). On the other hand, if a sentence appears without an object (I'm sleeping), one cannot always posit an underlying node for one. The "subjects" of NP's are also optional: in Destruction is inevitable, there is no evidence for an underlying "subject" of destruction.

If there is indeed a relation between Emonds' hypothesis and (25)-(26), then passives must lack deep structure subjects. In other words, if (25a) is itself derived from The enemy destroyed the city, the subject node will have been occupied and Emonds' hypothesis could explain nothing about the difference between (25) and (26).

Here I will sketch a possible empty-subject source for the passive. (The account will be essentially a modification of Hasegawa's analysis (Hasegawa 1968).⁴ Let us suppose that the passive morpheme be (+EN) is similar to the

semi-auxiliaries of (ii) in requiring an empty subject NP. These assumptions give us two possible sources for the passive, (27a) or (27b):

27) a.

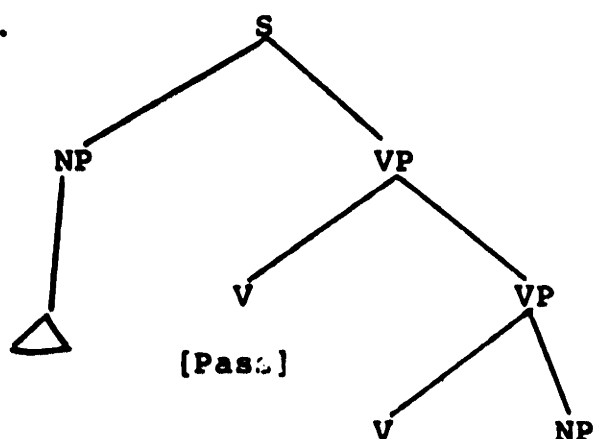

b.

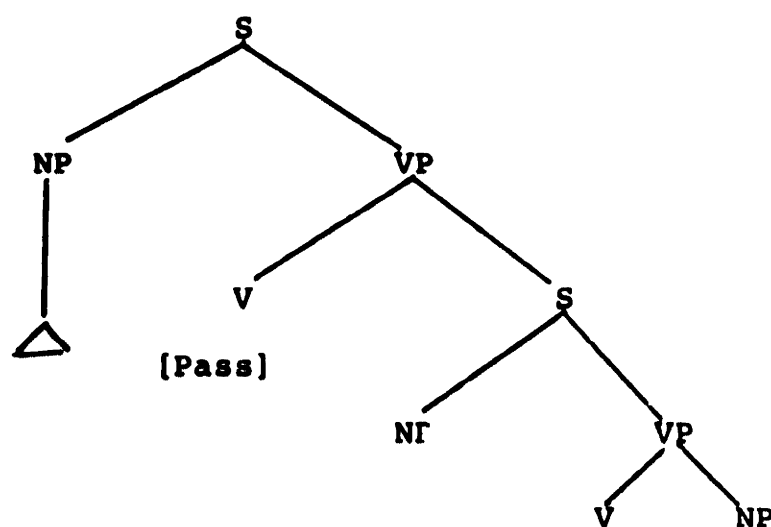

There are several reasons for preferring (27a) to (27b). First, while the subject node is obligatory in English, the "agent node" (by phrase) is not. This fact is not explained by the hypothesis that every passive verb has a deep structure subject (as in (27b)), which must be evacuated into an agent position. To be sure, it can be described by introducing an optional agent-deletion transformation; but the

fact that a transformation deletes agents is accidental. In (27a), an agent-phrase can be optionally introduced by the phrase structure rules, as can other optional prepositional phrases. On the other hand, an apparent advantage of (27b) over (27a) is that the former automatically accounts for the identity of selectional restrictions between the subject of an active verb and the agent of a passive, while the latter must state these separately:

28) a. John was examined by a doctor.

b. #John was examined by a tomato.

29) a. A doctor examined John.

b. #A tomato examined John.

This advantage is only apparent, however, because rules for interpreting by phrases are needed anyway to account for (30) and (31):

30) a. That is by Beethoven.

b. #That is by a tomato.

31) a. a sonata by Beethoven

b. #a sonata by a tomato

One might attempt to derive (30) from a passive (and thence from an active):

32) That was [written/composed] by Beethoven.

Then (31) might be derived by relative clause reduction from

33) a sonata which was [written/composed] by Beethoven

The tense difference between (32) and (30) as well as the

ad hoc character of the verb deletion transformation make this analysis implausible (e.g., in a record by the Yale Quartet, the deleted passive verb would have to be different from written, composed -- similarly for a performance by the Yale Quartet). But it has a worse defect. Consider (34):

- 34) Mary's records by the Yale Quartet are the best in her collection.

The by phrase cannot come from relative clause reduction, for a non-restrictive (appositive) relative clause would give the wrong meaning:

- 35) Mary's records, which are by the Yale Quartet, are the best in her collection.

And a restrictive relative clause is not possible with a possessive determiner:

36) *Mary's records which are by the Yale Quartet... Still another modification might be made to preserve the selectional generalization; (34) might be derived from (37):

- 37) The records which Mary has which are by the Yale Quartet are the best in her collection.

In other words, the possessive determiner might be itself derived from a relative clause, and both clauses would undergo relative reduction together to rule out (36). Yet this means of getting the possessive out of the way to allow a restrictive cannot be used in cases like (38):

38) {Her
The soprano's} short piece by {Bartok
#a tomato} received
the most applause.

(39) is not at all a plausible source for (38):

39) *The short piece which {she
the soprano} had which was
by...

It must be concluded that interpretive rules are needed to compose the readings of by phrases with the meaning of the rest. The selectional generalizations cannot all be expressed transformationally. Consequently, the advantage of (27b) over (27a) in this respect is only apparent.

A second reason for preferring (27a) to (27b) is the existence of passives which do not have a viable active source, such as be born (noted by Emonds): There's one born every minute has only a very awkward active counterpart in Someone bears one every minute, which may in fact be obsolete in many dialects. This verb can be subcategorized for (27a); if (27b) were the source of the passive, an underlying subject would have to be assumed which never occurs as a surface agent: *There's one born by some woman every minute. Another passive lacking an active counterpart or an agentive by-phrase was pointed out to me by Richard Oehrle: The Jones have just been killed in an auto accident.

A third reason for preferring (27a) to (27b) emerges from the following considerations. Most verbs strictly

subcategorize only within the VP, which is why Chomsky (1965) characterized strict subcategorization rules as "local" transformations. Verbs which are strictly subcategorized for empty subjects, like the subjectless semi-auxiliaries, are an exception. Another exception may be certain "middle verbs" (e.g., resemble, cost, last) which seem to logically require filled subjects, in that they do not passivize. Verbs which impose a syntactic condition upon their subjects, whether to be filled or unfilled, are thus distinct from the majority of verbs which would be free to go into active or passive deep structures. It thus is possible that all verbs which strictly subcategorize their subjects are non-passivizable: those verbs which can be inserted into the VP complement of passive be (in (27a)) must have no structural requirements outside the VP. If it could be independently motivated, this would be a very significant generalization. (Chomsky has observed to me that the "strict subcategorization" I have referred to here could be regarded as selectional if formulated carefully.)

This analysis of passives makes it possible to eliminate conditions and restrictions on the passive rule. There is no need to consider the rule obligatory in some cases (e.g., be born) and inapplicable in others (e.g., resemble). Rather, the rule will apply without exception to "passive" structures, shifting NP into subject position; Emonds' filling hypothesis will account for its obligatoriness in sentences.

Many verbs are "complex", consisting of a simple verb together with a closely adhering preposition, noun, or both. Jespersen (MEG #III.15.74) writes,

The ordinary grammatical school-analysis has some difficulty with these constructions; in I was taken notice of it will evidently not do to say that I is the subject of was taken, and notice the object of taken; but in reality nothing hinders us from saying that take notice of is a verbal phrase governing an object (me), which can be made into a subject if the whole phrase is turned into the passive.

Other examples are to send for, to take advantage of, to make much of, to live in [=reside in], look at, listen to. One test for a complex verb is the "adherence" of the postverbal material to the verb. Normally, a PP can be

clefted: It was to John that I directed my remarks;

but the complex verb resists this:

- 40) a. I like listening to records.
 b. It is records that I like listening to.
 c. *It is to records that I like listening.
- 41) a. They made much of John.
 b. It is John they made much of.
 c. *It is of John that they made much.
 d. *It is much of John that they made.

(40c) and (41c,d) show that parts of a complex verb do not easily cleft. Note that It's England that I hated living in is better than ?It's in England that I hated living, which means something quite different, e.g., "It's when I was in England that I hated being alive." Also, I find For whom were they sending when I came into the room? (from "They were sending for someone when I came into the room") quite artificial.

If we accept that there are complex verbs, there is no need to modify the passive rule itself to derive "double passives" such as Advantage is being taken of Bill, Bill is being taken advantage of; Much was made of his hairstyle, His hairstyle was made much of. The outer NP in the following diagram will fit the structural description of the passive rule:

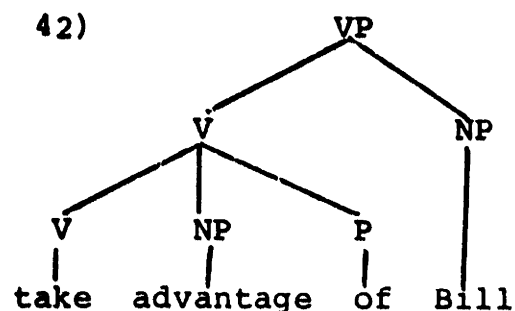

The inner NP is subject to heavy restrictions, e.g., *He was found many grave faults with (Jespersen MEG III 15.73), (cf. He was found fault with); and there is doubtless much individual variation in the properties of such complex verbs -- facts which are consistent with their analysis as lexical items. Whether the inner NP can be passivized from structure (42) or whether another structure is the source of Advantage is being taken of Bill, I leave open.

Finally, it is possible that some cases of apparent passivization are actually derived by Subject Shift. It may be that the exceptional verbs be said, be rumored, be reputed have the synchronic status of semi-auxiliaries like seem. Their behavior is quite similar to seem: *That S is rumored/generally said/reputed; *What is rumored/generally said/reputed?; There are rumored/generally said/reputed to be more women in the world. These verbs do not share properties of true passives; compare e.g., It is being said that there are more women in the world to *There are being said to be more women in the world. Note also the ungrammaticality of *They say/rumor/repute there to be more women..., a fact which would follow if these

were subjectless, and hence liable to the Subject Shift transformation.

In conclusion, I have claimed that the subjectless semi-auxiliaries, to which we may add be said, be rumored, be reputed, can have a bare S as complement, unmediated by a complementizer. These verbs, including begin, continue, tend, be apt, come, turn out, chance, seem, be likely, are all "aspectual", in a broad sense of the term. Bearing a close semantic resemblance to the aspectual auxiliaries or the modals, they present the "aspect" in which the plain content of the S is seen. A subjectless semi-auxiliary either "indicates the lapse of action, its nature from the standpoint of continuity", or else "expresses the source or nature of the speaker's knowledge (known by actual experience, by hearsay, by inference)" -- to borrow Sapir's description of some of the functions of "aspect" and grammatical form (Sapir 1921:108-109). In the next section we will see that a certain class of mostly epistemic verbs also takes a bare S complement. Verbs having such complements may form a natural, if specialized, semantic class.

One might object, "How could subject-shifting verbs form a semantic class, if likely belongs but its synonym probable does not: Mary is likely to win vs. *Mary is probable to win?" This objection tacitly assumes that semantic function determines syntactic properties -- which

is obviously false. A given syntactic category or construction may have an associated semantic function without implying that there is no other syntactic way of saying something similar. For example, the syntactic category of modal auxiliaries (including may, can, would, etc.) has a characteristic semantic function, but there do exist non-modal synonyms to some of the individual members of the category (e.g., can and be able). In this case, too, meaning does not determine syntactic properties (e.g., Can you do it? vs. *Are able you (to) do it?).

C) The Accusative and Infinitive

Certain predicate complements consist of a NP followed by an infinitival VP of which the NP is understood as the subject. These are traditionally called accusative and infinitive constructions (in distinction from the "nominative and infinitive" produced by the Subject Shift transformation), because the NP, if a pronoun, occurs in the "accusative" case. Examples are

- 1) I wanted him to be better than he was.
- 2) I believed him to be better than he was.
- 3) I challenged him to be better than he was.

Examples (1)-(3) actually have very different deep structure sources, despite their surface similarity, but as a group they can be distinguished from the type of construction shown in (4), in which the subject of the infinitive is

not understood as the preceding NP:

4) I bought it to establish myself as a connoisseur.

The infinitival in (4) is a purpose clause: as the reflexive myself shows, it cannot be the subject of this infinitive. It is important in what follows to distinguish the purposive infinitive from the infinitival complement.

Examples (5)-(7) show how ambiguities could arise between the two types, accusative and infinitive vs. purposive:

5) a. I wanted the experience to improve me.

b. I wanted the experience to improve myself.

6) a. I believed that story to be a true story.

b. I believed that story to be a true believer.

7) a. I challenged him to prove himself innocent.

b. I challenged him to prove myself innocent.

Usually, so as can be inserted before the purposive infinitive (5b-7b), but never before the complement (5a-7a).

Of the accusative and infinitive complements, some must be analyzable as a single clause at some stage in their derivation. Taking (8) and (9) as examples,

8) In the future I want you to clear the room.

9) Mary believes John to be a spy.

We can infer that the underscored complements are clauses at some stage from the fact that transformations defined on clauses apply to them (or similar complements):

- 10) a. In the future I want the room to be cleared by you.
- b. I want there to be adequate meals provided.
- c. I don't want her to turn out to be a spy.
- 11) a. Mary believes a spy to have been planted among us.
- b. Mary believes there to be a spy among us.
- c. Mary believes John to have turned out to be a spy.

(a)-(c) show the effects of Passive, There Insertion, and Subject Shift.

Rosenbaum (1967) pointed out that in cases like (8) and (9) or (1) and (2), actives and passives in the complement are roughly synonymous; the same may be said of cases involving Subject Shift: (10c) and (11c) are roughly synonymous to (12) and (13), respectively:

12) I don't want it to turn out that she is a spy.

13) Mary believes it to have turned out that John is a spy.

By contrast, the NP following challenge is much more restricted:

14) a. *I challenged it to turn out that Mary is a spy.

b. *I challenged there to be people examined by my sister.

Note the nonsynonymy of actives and passives with challenge;

- 15) a. I challenged my sister to examine them.
 b. I challenged them to be examined by my sister.

To explain the difference between challenge, on the one hand, and want and believe on the other, syntacticians have proposed that the two types of verbs fit into different deep structure configurations, with only challenge having a direct object in deep structure:

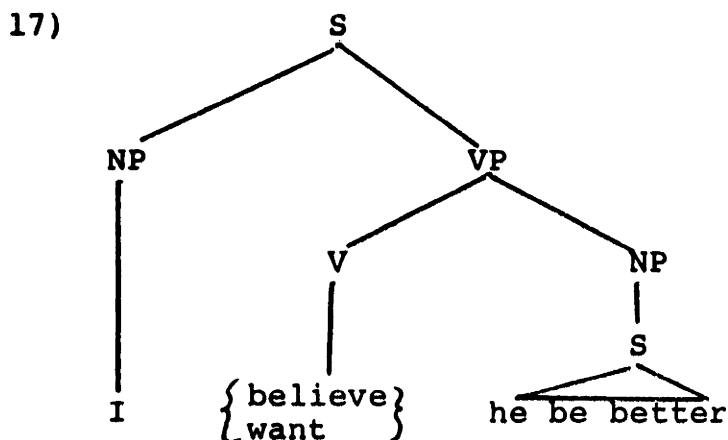
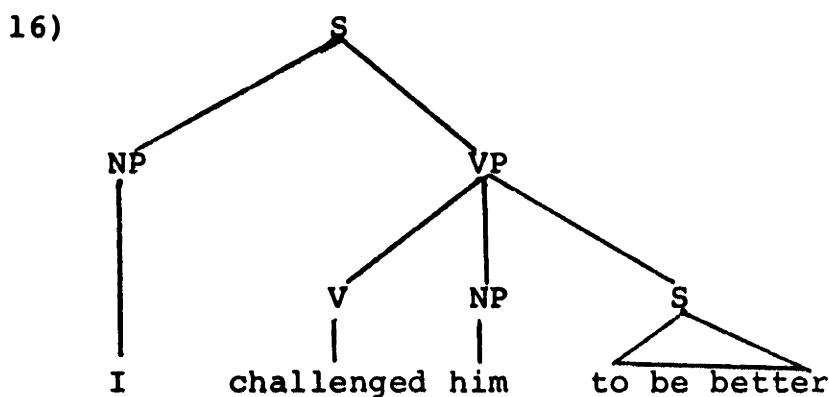

I will refer to the structure in (16), which underlies challenge-like constructions, as "the double-object construction", since the NP and S are parallel objects.

The class of verbs like challenge includes force, persuade,

convince, defy, oblige, urge, forbid, enjoin, command, and many others having a similar "compulsive" flavor. There are, in addition, a number of verbs which have both deep structure possibilities (16) and (17); I will return to these below.

What interests me here is not the difference between challenge and the superficially similar want and believe, which is fairly well explicable in terms of the double-object analysis, but rather certain differences between want and believe-type verbs themselves.

(i) The Problem: Two Paradigms

Both want and believe have accusative and infinitive complements which are clauses at some stage. But the complements show syntactic differences which turn out to be paradigmatic for semantically related verbs.

(I) First, believe-type verbs never appear with for, but want-type verbs do:

- 18) a. She believes her friends to be truthful.
 b. *What she believes (in) is for her friends to be truthful.
 c. *She believes strongly for her friends to be truthful.

- 19) a. She wants her friends to be truthful.
 b. What she wants is for her friends to be truthful.
 c. She wants very much for her friends to be truthful.

The difference also shows up in nominals: *belief for vs. desire for. Like believe in (18) are such verbs as suppose, consider, deny, assume, prove, understand, perceive. Like want in (19) are desire, prefer, like, hate, love, wish.

(II) Second, the subject of the infinitive can be passivized with respect to believe-type verbs, but not want-type verbs:

20) They are believed to be truthful.

21) *They are { wanted
 desired
 preferred
 liked
 hated
 loved
 wished } to be truthful.

It is sometimes suggested that verbs like want simply do not passivize. This can be shown to be false:

22) Public transportation is not { wanted
 desired
 preferred
 liked
 hated
 loved
 ?wished } by everybody.¹

Alternatively, it has been suggested that want-type verbs do permit passivization of simple direct objects, but

passivization of the subject of the infinitive would introduce confusion with the subjectless infinitive (I want to be truthful), and hence is avoided. While it certainly is true that removal of the subject can introduce ambiguity, this proposal is inadequate as an explanation of (II) for a number of reasons.

In section (A) we saw that several movement transformations could extract the subject of the infinitive, so long as the complementizer had been deleted:

- 23) a. The things I want to happen are impossible.
- b. Worse things than you would want to happen to a dog...
- c. John I don't want to visit me.
- d. It's Mary who he doesn't want to be successful.
- e. What I want to happen is this.
- f. Who do you want to visit you?

In general, if we choose infinitives which permit little ambiguity, it is possible to remove the subject:

- 24) Who would you like to visit you on your birthday?
- 25) The women who we would prefer to represent us are not candidates.
- 26) Those who you desire to govern you should not be those who desire to govern you.
- 27) Which do you wish to be sent to your husband?
- 28) ?Which facts would I most hate to fall into the hands of my enemies?

Love and hate are the most resistant to extraction of the subject, and this may be related to the fact that they often retain the for in, e.g., I('d) love (it) for..., I('d) hate (it) for....

Therefore, the proposal that too much ambiguity is introduced by passivization of the subject of the infinitive does not stand as an explanation. Furthermore, there is no possibility of ambiguity in the following. And if (23)-(27) are possible, what explains the differences in (28) and (29)?

- 28) a. It is believed to be raining.
 b. *It is wanted to rain.
 *It would be liked to rain.
 *It is preferred to rain.
 *It is desired to rain.
- 29) a. There is believed to be enough for everyone.
 b. *There is wanted to be enough for everyone.
 *There would be liked to be enough for everyone.
 *There would be preferred to be more.
 *There is desired to be more.

There are two further reasons for supposing that this difference between want and believe represents a fact of systematic interest. Consider examples (30a,b):

- 30) a. These women want a legal education to prepare them to assault invidious laws.

- b. These women want a legal education (mainly)
to prepare themselves to assault invidious laws.

(30a) contains a true accusative and infinitive complement and (30b) contains a direct object followed by a purpose clause. If we apply the passive, only the purpose reading comes through:

- 31) a. *A legal education is wanted by these women to
prepare them to assault invidious laws.
b. ?A legal education is wanted by these women
(mainly) to prepare themselves to assault
invidious laws.²

(31a) cannot be read as a true accusative and infinitive;
cf.

- 32) a. What a legal education is believed to do is
to prepare one to...
b. *What a legal education is wanted to do is to
prepare one to...

Therefore, it seems to be some property of the complement itself which prohibits passivization with want -- and not an accidental effect caused by collocating passives and infinitives.

A second reason for this conclusion develops from considering verbs like challenge, which have double objects. These verbs regularly allow passivization, as is well known:

Linda was challenged to prove herself innocent, Mary was forced to lie to save her sister, Nell was persuaded to be

examined by a woman specialist, etc. Some of the verbs which have this structure also occur with single (sentential) objects, notably order (as a nominal) and command.

- 33) a. Linda ordered the men to leave the meeting.
 b. Linda's order that the men should leave the meeting was rapidly obeyed.
- 34) a. Mary commanded the troops to cease their firing.
 b. Mary commanded that the troops cease their firing.

In the double object construction, as with challenge, both order and command permit passivization of the direct object: The troops were commanded to cease their firing; The men were ordered to leave. However, an interesting possibility now arises: if command and order have in addition to a double-object complement a single sentential object, they might very well be expected to occur with a single object for clause, like the want-type verbs. This in fact seems to be the case:

- 35) a. She has ordered the bodies to be dragged away.
 b. She has commanded the prisoners to be shot.

One can order someone [=issue an order to someone] to drag bodies away, but when one orders bodies to be dragged away, the order is not issued to the bodies-- rather, the contents of the order is "for bodies to be dragged away". Similarly, one can command a prisoner [=issue a command to her or him] to do something, such as be examined by a doctor, be shot, etc. This is the double object construc-

tion. But one can also issue a command, the contents of which is for prisoners to be shot. This suggests that in (35), the accusative and infinitive belong to the same clause, a for complement. For does in fact show up when an adverb intervenes postverbally, as with want very much for...:

- 36) a. *She ordered last night the bodies to be dragged away.
 b. She ordered last night for the bodies to be dragged away.
- 37) a. *We felt that she would never command, no matter what happened, the prisoners to be shot.
 b. We felt that she would never command, no matter what happened, for the prisoners to be shot.

In sum, these verbs participate in both double object and single object constructions, like challenge and want, respectively. As we have seen, the double object constructions allow passivization with respect to the main verb; however, the single-object ones do not:

- 38) a. *The bodies have been ordered to be dragged away.
 b. *The prisoners have been commanded to be shot (without knowing it).

Once again we see confirmation of a systematic difference

between want and believe. These facts throw out the hypothesis that ambiguity causes one to avoid the passive, since here we have constructions involving identical verbs, and still the want-type construction (with a for complement) prohibits the passive, while the other type does not.³

(III) The third paradigmatic difference between want- and believe-type verbs is that the former but not the latter undergo Equi-NP Deletion:

- 39) a. Alice wants to learn karate.
 b. Betty prefers to study aikido.
 c. Catherine desires to become proficient at Pushing Hands.
 d. Doris likes to practice Chinese Temple Boxing with her sister.
 e. Edith loves to do T'ai Chi exercizes.
 f. Frances hates to waste her time on archaic martial arts.
 g. Gill intends to get a pistol.
- 40) a. *Al believes to have done the laundry enough.
 b. *Bill supposes to be a good cook.
 c. *Charlie denies to have threatened to wash the dishes for the last time.
 d. *Dave considers to be above mopping the floor.
 e. *Ed assumes to be living evidence that anatomy is destiny.
 etc.

This difference is closely related to (I), since in general any construction involving a for complement may undergo Equi-NP deletion, and as we have seen, the want-type verbs evince underlying for complements. [Structures other than the for complement permit Equi, e.g., WH infinitives and gerunds. It is a problem to explain what types of structures are not subject to Equi.]

(IV) The fourth difference is that believe-type verbs permit the subject of the infinitive to be reflexive, while want-type verbs do not. Thus, if we interpose herself in (39) between the main verb and the infinitive, the result, while interpretable, is jarring: ?Alice wants herself to learn karate; ?Betty prefers herself to study aikido; ?Catherine desires herself to become proficient..., etc. By contrast, the insertion of himself in (40) yields fully grammatical sentences: e.g., Ed assumes himself to be living evidence that anatomy is destiny.⁴

In summary, we have the following paradigms:

| 41) | <u>want</u> -type | <u>believe</u> -type |
|--|-------------------|----------------------|
| I) takes <u>for</u> complement | + | - |
| II) permits passivized subject of infinitive | - | + |
| III) permits Equi | + | - |
| IV) permits reflexive subject of infinitive | - | + |

We must find a way of explaining these differences.

Before turning to proposed solutions in the next section, let us first consider what we will count as an explanation. Obviously, we want some way of relating the clusters of syntactic properties in (41). Anything which is equivalent to this matrix of +'s and -'s will be merely a redescription of the problem. Furthermore, a true explanation should provide some insight into why the syntactic clusters seem to correspond to the given semantic classification: in other words, there must be a reason why want-type and believe-type verbs are not randomly distributed with respect to the columns, and why the want-type does not head the believe-type column and vice versa.

Of course, it is always possible that a correlation matrix like (41) will reflect no generalization at all. I have chosen the four properties listed because I believe they do reflect the systematic role of the complementizer. Furthermore, I have restricted consideration to relatively "pure" types of verbs like want and believe, against which mixed cases can be analyzed. If we had taken a verb like expect as paradigmatic, nothing would be revealed as systematic, since expect has properties of want, believe, and challenge -- all three types of accusative and infinitive constructions in (1)-(3). For example, in (42), expect behaves like want, allowing a for complement and permitting Equi:

- 42) a. I don't expect at all for you to believe me.
- b. I don't expect to be believed.

In (43), expect behaves like challenge, a "double object" verb:

- 43) a. As long as I'm boss, I will expect everybody to have a share in the office work.
- b. As long as I'm boss, everybody will be expected to have a share in the office work.

In (43), expect has a compulsive sense, requires an animate object like challenge, and its direct object can be passivized, as with challenge. So far, then, expect is like order, having either a double object (challenge-type) or a for complement (want-type). Accordingly, we find that the sentence I will expect you to remove the tables after each session is ambiguous, either describing an expectation ("I will expect this: for you to remove...") or expressing what is expected of you ("You will be expected to remove the tables..."); but the sentence I will expect the tables to be removed after each session lacks the second interpretation (#The tables will be expected to be removed after each session). In this way, expect is analogous to order (see (32)-(38)).

However, in addition to these two subcategorizational possibilities, expect has still another, in which it behaves like believe. Here its meaning differs: the sense is not so much intentional or compulsive as predic-

tive, e.g., I expect her friend to be quite tall. As with believe, passivization is possible here too: Her friend is expected to be quite tall. (Of course, the distinction between prediction and intention may in fact get blurred, especially when the subject is predicting something of her/himself.) Thus we find a difference in acceptability between (44) and (45):

44) #The Qualifying Exam $\left\{ \begin{array}{l} \text{will be} \\ \text{is} \end{array} \right\}$ expected to be passed by June of your second year.

45) The Qualifying Exam is expected to be given in June.

In (44), expect is understood like want: "They (will) expect the Qualifying Exam to be passed by June of your second year" -- said by an old student to a new student. As in want-type verbs, passivization of an NP from the for complement is blocked. But in (45), expect is understood like believe, and passivization of an NP from the complement is allowed.

In conclusion, the complex behavior of expect can be analyzed into three simple patterns, in which the semantic-syntactic correlations are preserved: the "compulsive" expect takes a double object complement like challenge; the "intentional" expect takes a for complement like want; and the "predictive" expect has the syntactic properties of epistemic verbs like believe. (The semantic notion "predictive" may itself be analyzed as "future

epistemic".) Expect thus provides further evidence that the correlation matrix of (41) does indeed reflect some systematic underlying difference between want- and believe-type verbs.

The differences in (41) have in general been well-known, if not stated precisely as here. I am indebted to Howard Lasnik for many discussions in which this material became clarified; most of the preliminary research on the problem in (i) and on the solution in (iii) was done jointly with him in preparation for a paper on the topic; many of the same facts have been observed by Aijmer (1972). Let us now see how these facts are accounted for by previous analyses.

(ii) Previous Analyses

In Rosenbaum's study (1967), the for-to complementizer is assumed to underlie all occurrences of such infinitival complements, whether or not for can actually appear in surface structure. The differences between believe and want in (41) are attributed to special devices governing rule application. Rosenbaum's Extraposition transformation, an optional rule, is made obligatory for believe-type verbs, but either optional for or inapplicable to want-type verbs (see the discussion in Rosenbaum 1967:53-69). This difference in turn causes the differential application

of other transformations, such as his Pronoun Replacement. A derivation is illustrated in (46). (In this derivation, Rosenbaum's complementizer-placement rules are ignored.)

- 46) a. She believes [_{NP} [_Nit] [_Sfor her friends to be truthful]] \Rightarrow (Extrapolation)
- b. She believes [_{NP} [_Nit] _{NP}] [_Sfor her friends to be truthful] \Rightarrow (Pro Replacement)
- c. She believes [_{NP}her friends_{NP}] [for to be truthful] \Rightarrow
- d. She believes [_{NP}her friends_{NP}] [\emptyset to be truthful]

Observe that the effect of step (a) -- so-called vacuous extraposition -- is to set up an NP and S as separate constituents; step (b) then replaces the it by the NP subject of the S.

The obligatoriness of this sequence of rules "explains" fact (I) of paradigm (41) -- that for does not show up with believe. The other facts of (41) can be made to follow from this if we assume that Pro Replacement does not apply to want-type verbs. The passive rule will apply to the derived object of believe, but not to the NP follow-int want, accounting for (II).⁵ As for the other facts in (41), reflexivization can only occur within a simple S, explaining (IV), and Equi can only apply to the subjects of S's, explaining (III).

Although this account relates the properties in paradigm (41), it has several defects. First, there is no evidence, syntactic or semantic, that a for complement underlies the accusative and infinitive of believe-type verbs. Second, the Pro Replacement transformation in (46) violates the Fixed Subject Constraint by shifting a NP across a COMP. Reordering for deletion before Pro-Replacement would not solve this problem, since when an it intervenes between verb and for, the complementizer is normally retained (I hate it {^{*∅}for} ...; I consider it stupid {^{*∅}for} him to do that; see (46b)). Third, the account is arbitrary: want could just as well behave like believe and vice versa; or want- and believe-type verbs could be randomly distributed with respect to properties (41), since there is no way of telling which verbs will have the obligatory sequence in (46). It remains to be explained why obligatory extraposition and Pro Replacement could not apply to want-type verbs.

Later treatments have modified Rosenbaum's original analysis but still leave unexplained the essential difference between want-type verbs and believe-type verbs and still require a violation of the Fixed Subject Constraint. In R. Lakoff's account, for example (1968:48), the complementizer that is changed by a rule to for-to, and then for believe (but not want) "It Substitution" is obligatory. "It Substitution" is a rule which simultaneously performs

steps (46a) and (46b). This account has a greater elaboration of devices for describing "irregular" syntactic behavior, including "redundancy rules" which correlate semantic features of predicates with chains of transformational rules (e.g., all predicates belonging to a certain semantic class are automatically assigned a set of transformational rule features in the lexicon). But the account assumes that the phenomena are irregular; the correlations are described but they are not explained. Therefore, the account is subject to the same fundamental objections as Rosenbaum's.⁶

An important step forward is made in Kiparsky and Kiparsky's "Fact" (1970). They explicitly reject the idea that all infinitive complements are derived from for complements, and claim that for does not occur at any stage in the derivation of the accusative and infinitive complements of believe-type verbs. This claim is based upon their insightful observation that for-to complements are limited to a class of predicates which express the "subjective value" of a proposition, the "emotive" predicates (p. 169). Though they suggest various independent symptoms of emotivity, it is intuitively clear that want, like, hate are more "emotive" semantically than believe, assume, consider. (For a discussion of the criteria of emotivity, see Karin Aijmer (1972).) For verbs like believe, Kiparsky

and Kiparsky suggest that the "accusative and infinitive" construction is derived by a transformation of Subject Raising (similar in effect to Rosenbaum's Pro Replacement and R. Lakoff's It Substitution), which lifts the subject out of a non-factive complement as diagrammed:

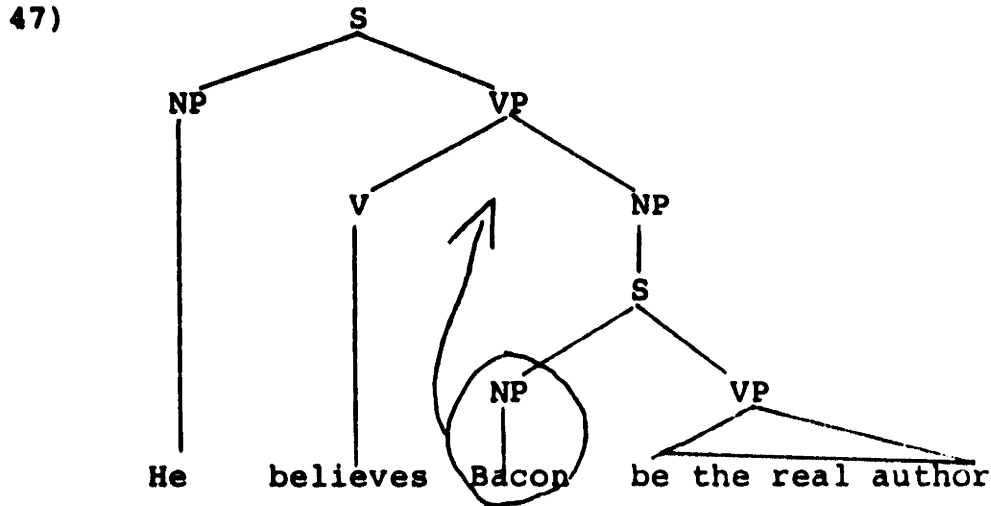

Formation of the infinitive is said to follow from a low-level process converting verbs without nominative subjects into infinitives.

On Kiparsky and Kiparsky's account, the paradigmatic differences between believe and want (II-IV) could all be attributed to the fact that Subject Raising applies to the former but not the latter. But several questions remain: why should the for-complement prohibit Subject Raising; what is the source of the accusative and infinitive with believe, if it is not a for-complement; and why is for limited to the class of emotive predicates? The answer to the last question lies in the semantic function of the

for complementizer, discussed in Chapter 2. The answers to the other two questions can be anticipated from our discussions of the Fixed Subject Constraint in Part A of this chapter, and of the bare S, or unmediated complement, which appeared in Part B. I turn to these in the next section.

(iii) A Possible Solution

If we assume the existence of a Subject Raising transformation, then we can account for the difference between want- and believe type verbs with respect to passivization, Equi, and reflexivization. But we are left with a rule which inexplicably raises the subject from the complements of some verbs and not others. Is it only accidental that the complements which prevent raising are prefixed by for at some stage in the derivation, while those which allow raising show no evidence, syntactic or semantic, of the for complementizer? By supposing that want-type verbs have a for complement in \bar{X} p structure, while believe-type verbs have the bare S complement, we can see how all of the problematic facts discussed above fall into place, including the applicability of Subject Raising.

Assume first that deletion of complementizers takes place after Passivization. This ordering is probably necessary anyway to account for (48):

- 48) a. The teachers are now assuming (that) no one will be able to find jobs.
- b. $\left\{ \begin{array}{l} \text{That} \\ * \emptyset \end{array} \right\}$ no one will be able to find jobs is no being assumed by the teachers.

If the complementizer were deleted before passivization, (48b*) would be derived. (It is hard to find examples where a for clause has been passivized into subject position. I do not know the reason for this fact.) But we are also assuming that the possibility of passivizing the subject of an infinitive depends upon Subject Raising. Therefore we have the ordering

- 49) $\left\{ \begin{array}{l} \text{Subject Raising} \\ \text{Passive} \\ \text{Complementizer Deletion} \end{array} \right.$

On this analysis it immediately follows that Subject Raising will not apply to want-type verbs, for it would have the effect of moving a fixed subject across the for complementizer.

In Part A, I showed that Question Formation and other movement transformations were blocked from applying to a subject fixed by an adjacent complementizer. This explained the difference between the examples in (50) and those in (51), among others:

- 50) Who would you like to visit you?
Who do you want to visit you?

51) *Who do you $\left\{ \begin{array}{l} \text{hope} \\ \text{long} \end{array} \right\}$ to visit you?

*Who would you be ashamed to visit you?

The examples in (50) have sources in which the subject is not fixed by for: You would like someone to visit you; you want someone to visit you. But in (51), the for complementizer has apparently been protected from deletion by the presence of an underlying preposition (for or of in these cases): You $\left\{ \begin{array}{l} \text{hope} \\ \text{long} \end{array} \right\} \left\{ \begin{array}{l} \text{for} \\ * \emptyset \end{array} \right\} \text{someone to visit you};$ You'd be ashamed $\left\{ \begin{array}{l} \text{for} \\ * \emptyset \end{array} \right\} \text{someone to visit you.}$ We therefore arrive at the further ordering

52) $\left\{ \begin{array}{l} \text{Complementizer Deletion} \\ \text{Preposition Deletion (before complementizers)} \\ \text{Question Formation} \end{array} \right.$

(Question Formation actually must follow all transformations on S, since, as a complementizer substitution transformation, it applies to \bar{S} , a "higher cycle".)

Thus the fact that want-type verbs (50) prohibit Subject Raising but allow Question Formation, while hope-type verbs (51) prohibit both, follows from the retention of the complementizer in the latter case, caused by the preposition. (Cf. *They $\left\{ \begin{array}{l} \text{would have liked} \\ \text{wanted} \end{array} \right\} \text{for our help}$ and They $\left\{ \begin{array}{l} \text{hoped for} \\ \text{longed for} \end{array} \right\} \text{our help.}$ -- Verbs like hope differ from want in taking PP objects.) We have the differential derivations shown in (53) and (54):

53) a.

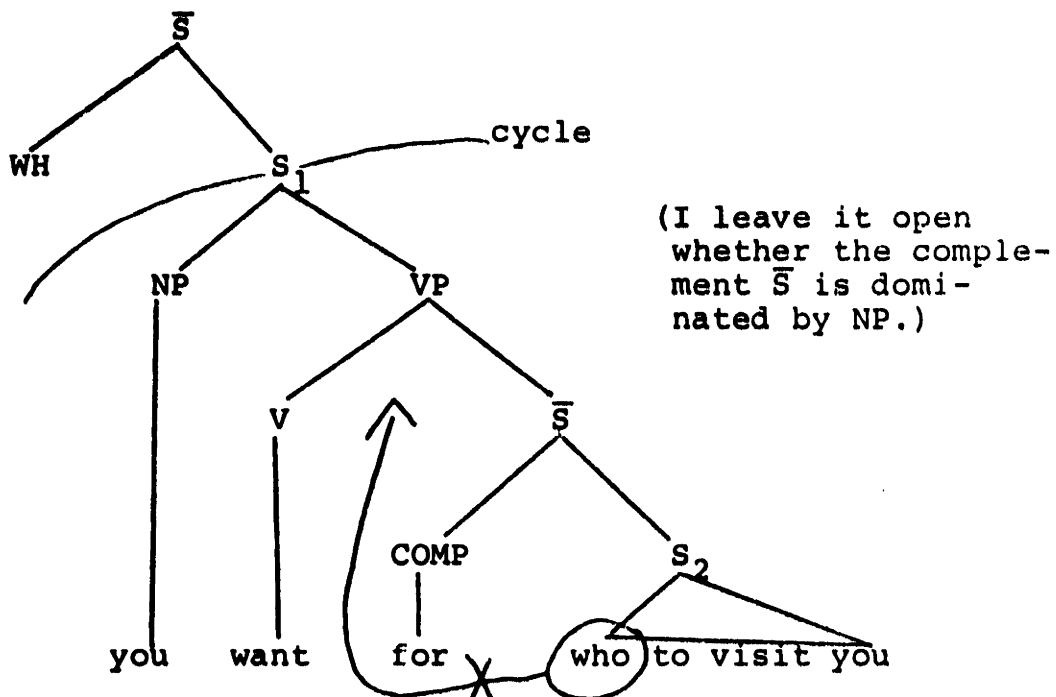

The Fixed Subject Constraint prevents Subject Raising on the S_1 cycle.

b.

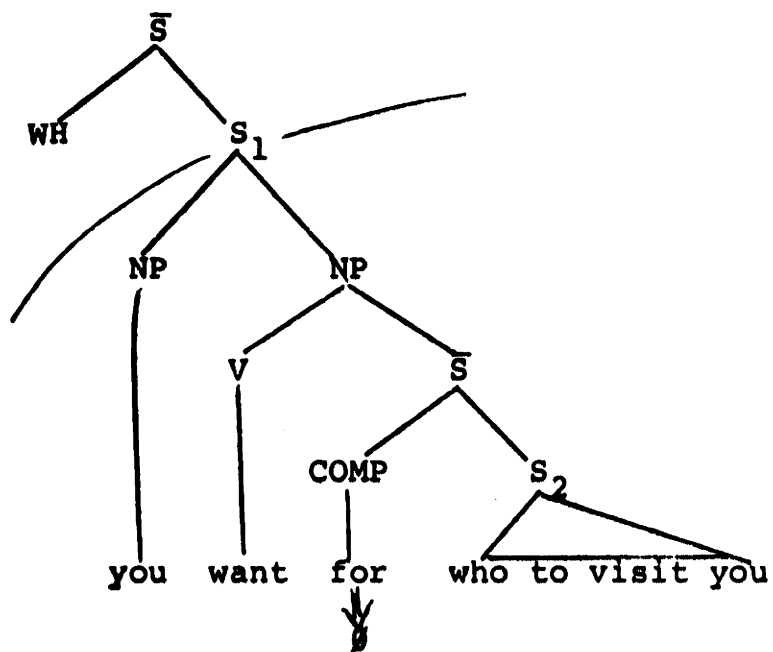

for complementizer is deleted.

53) c.

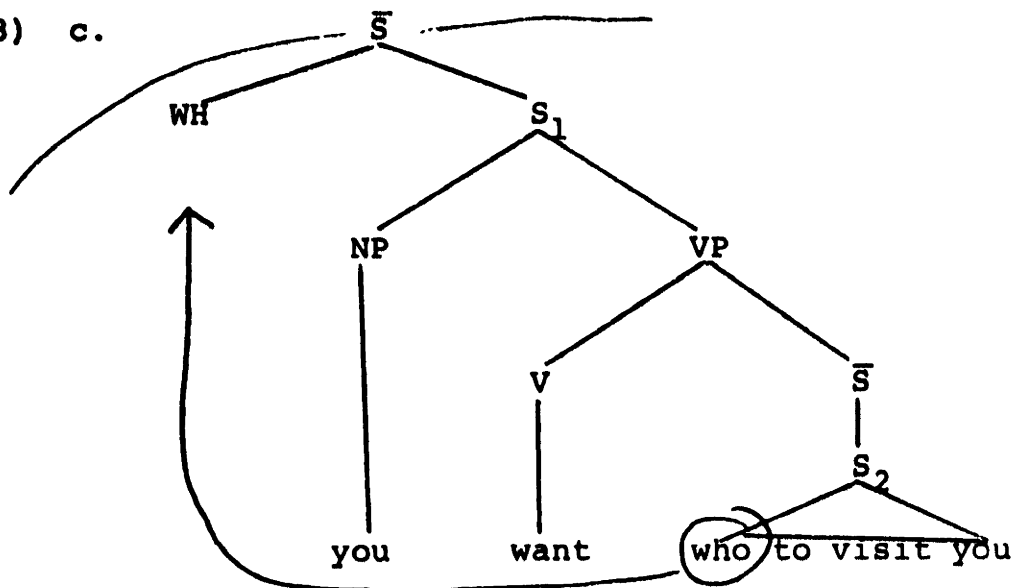

Question Formation applies (on \bar{S} cycle).

54) a.

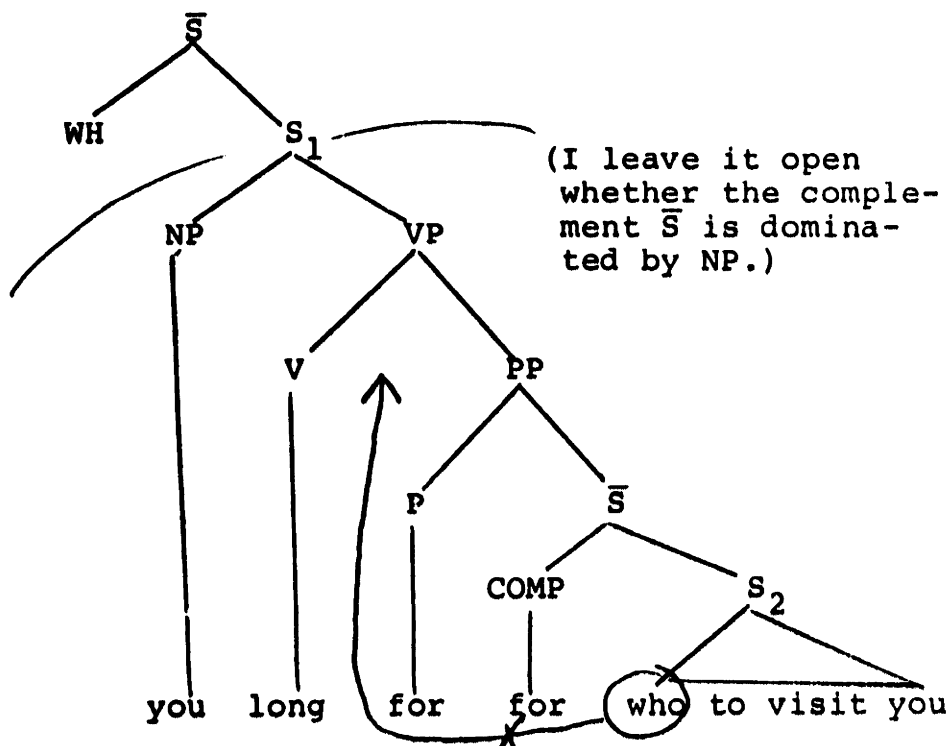

(I leave it open whether the complement \bar{S} is dominated by NP.)

The Fixed Subject Constraint prevents Subject Raising on the S_1 cycle.

54) b.

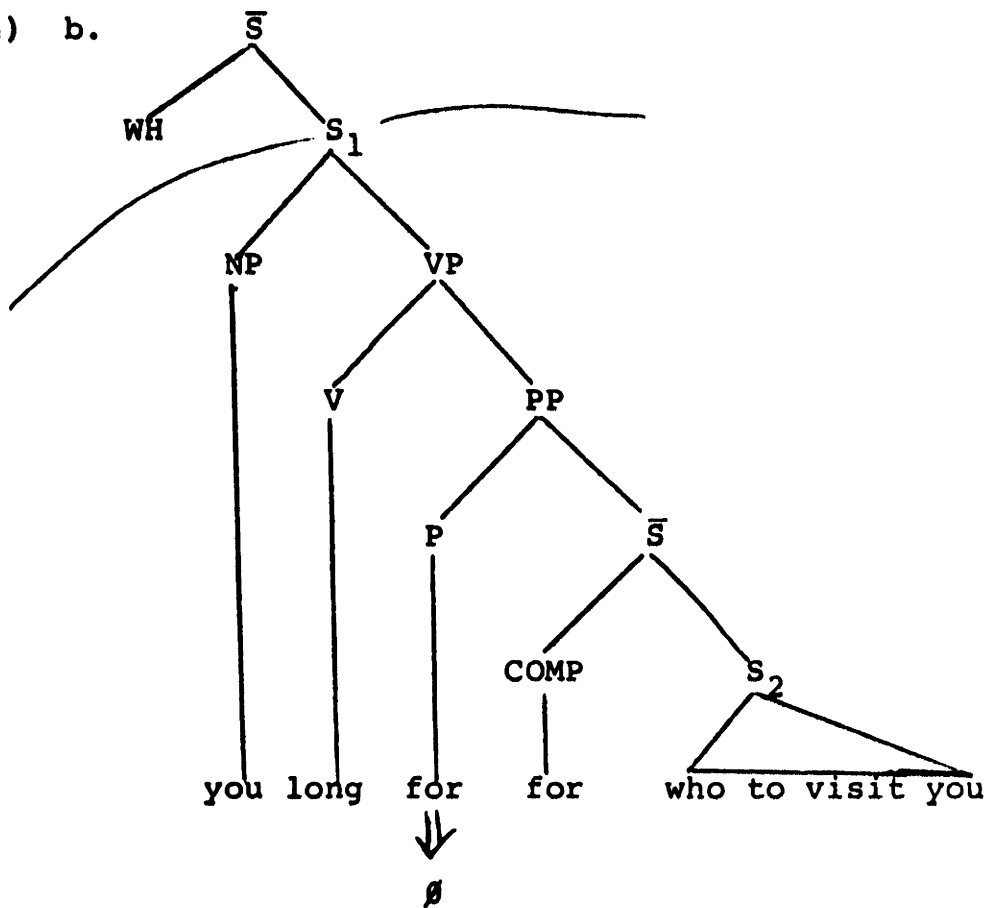

The preposition prevents complementizer deletion; then the preposition is itself deleted before the complementizer.

54) c.

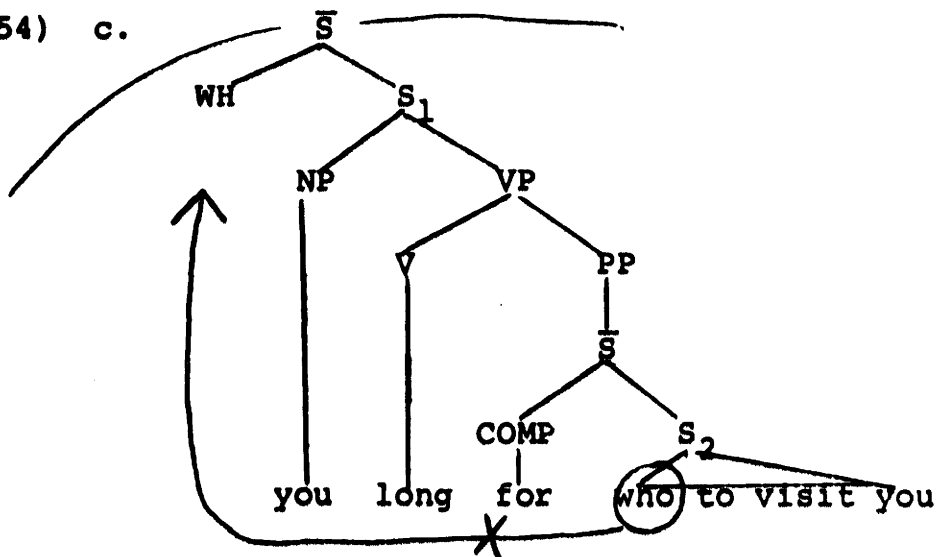

The Fixed Subject Constraint prevents Question Formation.

We have answered the first question posed by Kiparsky and Kiparsky's analysis -- why the for complement prohibits Subject Raising in want-type verbs. The question remains, what is the source of the accusative and infinitive complement to believe-type verbs?

There are several objections to deriving the accusative and infinitive from a that complement. The first is that with the ordering established above [(49) and (52)], the Fixed Subject Constraint would prevent Subject Raising from a that complement. The second is that there are differences between the contents of a that complement and the contents of an accusative and infinitive to believe-type verbs, the latter being more restricted:

- 55) a. She believes that these problems are beginning to be more generally recognized.
- b. ?She believes these problems to be beginning to be more generally recognized.

A third problem is that there are many nonfactive verbs having that complements, which do not undergo Subject Raising. We would lose the explanatory advantages just gained if we had to resort to rule features to determine which verbs could not undergo the raising process. Such verbs include say, explain, deduce, agree, infer, conclude, entail, suggest, hint, imply, propose, dictate, hope: e.g., I hope that she is coming vs. *I hope her to be

coming; This problem suggests that we haven't done enough
 vs. *This problem suggests us not to have done enough.

We are thus led to the conclusion that the believe-type accusative and infinitive comes from a clause without a complementizer -- an unmediated complement. (The alternative would be an ad hoc rule to trim unwanted that's.) This conclusion means that the stock of verbs taking bare S complements includes not only the subjectless semi-auxiliaries -- seem, begin, etc. -- but also a set of "epistemic" verbs. The stock predominates in aspectual and "perceptual" verbs.

(iv) Problems with the Solution: Is There
 a Subject Raising Transformation?

In the solution sketched in the preceding section, I assumed the existence of a Subject Raising transformation like the one set forth in Kiparsky and Kiparsky (1970) and showed how my analysis of complementizers fills in several explanatory gaps in their account: want-type verbs take an underlying for complement while believe-type verbs take a bare S without a complementizer; the intrinsic semantic function of for governs its distribution among predicate types (Chapter 2); the Fixed Subject Constraint accounts for the inapplicability of Subject Raising with want-type verbs. Further research is needed to determine

whether this Subject Raising analysis is correct. It is possible that the bare S is intact in sentences like I believe Mary to be right, i.e., that there is no Subject Raising rule.

If we assume that there is no Subject Raising rule, we must account for paradigm (41) in some other way.

Property (I), the absence of for, follows from the bare S analysis; but how to account for properties (II)-(IV)?

Property (II) will follow if the Passive transformation precedes complementizer deletion and moves any NP contiguous to V on the right -- assumptions shared by the Raising analysis in (ii):

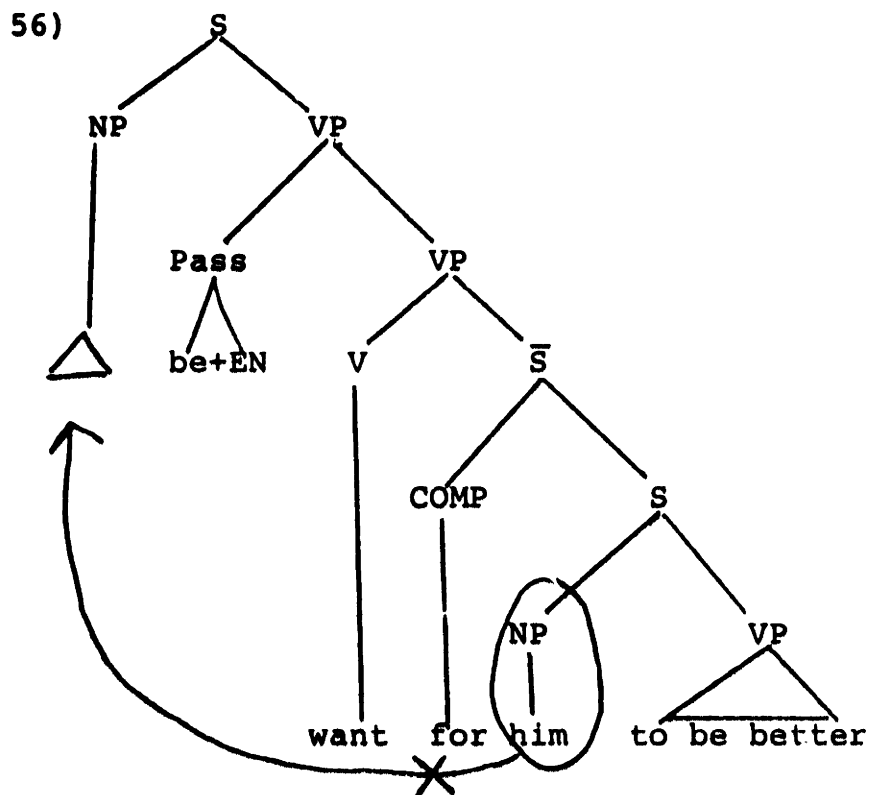

Derivation of *He is wanted to be better is prevented.

57)

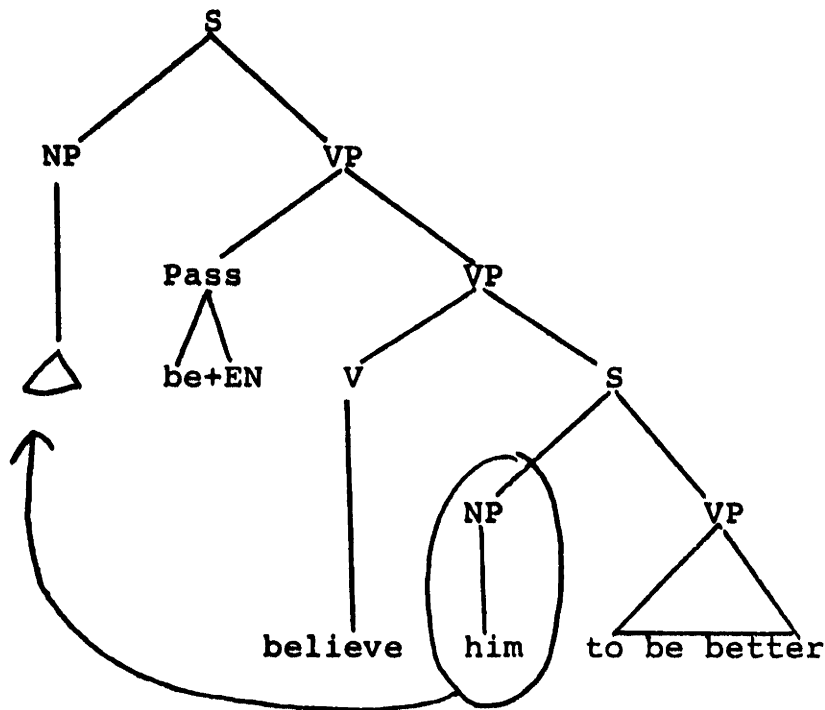

Derivation of He is believed to be better is allowed

Property (III), the impossibility of Equi with believe-type verbs, could be accounted for by restricting Equi to for-complements, and certain others. The types of complements to which Equi may not apply have not yet been accounted for anyway. Property (IV), the possibility of reflexive subjects with believe-type infinitival complements, seems to be the hardest to explain, for reflexives normally must be clause-mates of their antecedents.

(There are exceptions, such as "picture-noun" reflexives, but these are different from the reflexives under consideration.) Possibly the notion "clause-mate" could be defined in terms of \bar{S} rather than S: in other words, a bare S would be "transparent" to reflexivization, while an S

mediated by a COMP would not be. This in fact might be the reason that some people find ?I wanted myself to win much more acceptable than *I wanted very much for myself to win: when the for complementizer has been deleted, the complement resembles a bare S.

Many of the arguments given for and against Subject Raising are inconclusive. For example, in favor of Raising, an argument from Pseudo-Clefting has sometimes been given. The argument goes as follows. Only a single constituent may be pseudo-clefted:

- 67) a. Mary told John that he should go.
 b. What Mary told John was that he should go.
 c. *What Mary told was John that he should go.

But the accusative and infinitive after believe-type verbs cannot be Pseudo-clefted:

- 68) a. I believe John to have gone.
 b. *What I believe is John to have gone.

Therefore, it is argued, this accusative and infinitive is not a single constituent, but a sequence of constituents. Hence, Raising must have applied.

Note, however, that a bare S without a complementizer cannot be Pseudo-clefted:

- 69) a. What I wanted was for you to help me.
 b. *What I wanted was you to help me.

So the argument really shows nothing. Similar arguments

(e.g., from Gapping) have the same defect.

On the other hand, Chomsky (1971a) gives a possible argument against Subject Raising. He first observes that a NP can be questioned from certain picture noun complements when they occur in object position but not subject position:

- 70) a. You believe the agent has a picture of one of us.
 b. Which one of us do you believe the agent has a picture of?
- 71) a. You believe a picture of one of us was on the agent's wall.
 b. *Which one of us do you believe a picture of was on the agent's wall?

It turns out that the accusative and infinitive after believe obeys the same constraint:

- 72) a. You believe the agent to have a picture of one of us.
 b. Which one of us do you believe the agent to have a picture of?
- 73) a. You believe a picture of one of us to be on the agent's wall.
 b. *Which one of us do you believe a picture of to be on the agent's wall?

Therefore it looks as though Subject Raising could not have applied, since the "accusative" is still treated as a "subject of" the infinitive.

However, the constraint noted by Chomsky (70-71) seems to apply to objects followed by predicatives as well as believe-type complements:

- 74) a. He regards pictures of actresses as a form of exploitation.
- b. *What kind of actresses does he regard pictures of as a form of exploitation?

Consequently, this argument against Subject Raising is inconclusive.

One argument in favor of Raising is that "heavy" or complex NP's can often be positioned after a predicate which modifies them:

- 75) a. I'll consider any such future remarks you make treasonable.
- b. I'll consider treasonable any such future remarks you make.

The same holds for (76):

- 76) a. I'll consider any such future remarks you make to be treasonable.
- b. I'll consider to be treasonable any such future remarks you make.

However, Ross (1967) has examples like (76b) marked as marginal.

Subject Raised constructions share many other properties with NP predicative constructions (e.g., (75), (74)),

such as positioning of adverbs:

77) a. He secretly believes John to be a spy.

b. *He believes secretly John to be a spy.

78) He believes secretly that John is a spy.

79) a. He secretly regards John as a spy.

b. *He regards secretly John as a spy.

Further research on such properties may well yield evidence one way or the other on Subject Raising. The fact is that the accusative and infinitive complements to believe-type verbs share some properties of S clauses and some properties of NP Pred sequences. Many verbs which take "raised" structures also occur with NP Pred sequences:

I know him as a liar; I know him to be a liar. I consider this act as proof of your infidelity; I consider this act to be proof of your.... I take it as given...; I take it to be given; They think of me as a fool; They think me to be a fool.

Whether or not there is a Subject Raising transformation, it is clear that for is not the only source of infinitival complements. I have presented evidence that the bare S is also a source of such infinitives. A number of syntactic properties can be traced to the presence or absence of a complementizer. If we compare the evidence in this part with the results of the preceding, it emerges that complementizers affect many transformational processes in

predicate complementation -- inhibiting movement of the subject by Subject Shift and Subject Raising, or (if there is no Raising) defining domains in which reflexivization and Equi may or may not take place. The theory of predicate complementation must be revised to take account not just of the external relations between clauses and predicates, but also of the internal structure of the clause and, in particular, of the role of the complementizer.

FOOTNOTES

CHAPTER 3

SECTION A

1. Note that facts similar to (2)-(5) hold in embeddings:

I asked who you believe (*that) fired on you. *She wondered who they asked (that) go with them. This shows that these facts do not depend upon any special properties of main verbs such as whether they can occur as parentheticals, for parentheticals are not normally possible in non-quotative predicate complements: *I asked who, it seems, was there.

2. With the presence of a post-verbal adverb, extraction of the subject yields marginal results: ?Which one of her sisters does she want more than anything else to win? However, one cannot infer anything about the Fixed Subject Constraint from this fact, since sentences like the following seem equally marginal: ?Which one of her sisters does she want to win more than anything else?

3. The following sentence might appear to contradict this:

Washington, D.C. ought to be submerged, as I think
(*that) was suggested by Judge Rubin.

But notice that the complementizer that is ruled out independently:

Washington, D.C. ought to be submerged, as I think
 (*that) Judge Rubin suggested.

4. Though particular applications of Free Deletion are unconstrained by identity conditions, the possibility of free deletion in a given language may nevertheless depend on the condition on recoverability of deletions: see Robert M. Vago (1972). Vago argues that the possibility of subject pronoun deletion is predictable from the existence of unambiguous person oppositions in the unmarked verbal paradigm. If he is correct, then the counter-examples given by Perlmutter (1970:102) do not disprove the recoverability hypothesis as an explanation for subject pronoun deletion.

SECTION B

1. The semi-auxiliary chance seems to resist be: ?There chanced to be a copy of The Times on the table; They chanced to see him in the alley vs. ?He chanced to be seen in the alley. Worst for me is the pseudo-cleft: *What caught our eye chanced to be his hat. But compare *That chanced to be his hat.
2. One of these verbs has a corresponding nominal which takes for: tendency for. But the fact that a certain complementiser occurs with a nominal does not imply that it also occurs with a verb corresponding to the nominal:

invitation for (She issued an invitation yesterday for the men to attend the next meeting) to *invite for (*She invited yesterday for the men to attend the next meeting.).

3. We do have It came about that..., but no *John came about to be sick. There is no reason to expect that about would be deleted after subject shift, since out remains in John turned out to be sick

4. Hasegawa adopted a structure similar to (27b), except that the subject node was filled; thus, John was seen by someone would come from John was [+EN someone see John] by rules deleting the embedded object and shifting the embedded subject to a by-phrase. The empty subject version of Hasegawa's analysis (27b) would better explain the possibility of sentences like There are believed to be such things happening near the border, as the reader can easily verify.

SECTION C

1. Jespersen (MEG V, p. 316) cites an examples from Dickens which appears to contradict (II): He was wanted to bleed the prince. This might be a purposive infinitive; see also n. 3. below.

2. The grammaticality of (31b) is vitiated by a coreference

problem irrelevant to the point at issue: see Faraci (1971).

3. After citing an example in which the object of order occurs passivized ("they were ordered...to punish offenders"), Jespersen (MEG V, p. 317) observes, "It would not be possible to say "the table was ordered to be removed" as a passive to "he ordered the table to be removed"." By contrast, Zandvoort (Handbook, p. 20, 5th ed.) gives the example "The flag was ordered to be hoisted" together with "The victim is believed to have been poisoned". I find Zandvoort's example with order ungrammatical, and concur with Jespersen's observation. Confusion may arise because some double object verbs impose no selectional restriction of animacy upon their objects, e.g., allow permit. Allow and permit are like challenge in their strict subcategorization, but differ in selectional restrictions:

We $\left\{ \begin{array}{l} \text{allow} \\ \text{permit} \end{array} \right\}$ no secrets. #We challenge no secrets.

Thus we have as a possibility

The secret was $\left\{ \begin{array}{l} \text{allowed} \\ \text{permitted} \end{array} \right\}$ to leak out.

which is fully parallel to The men were challenged to improve their ways. Furthermore, some speakers may have

a want-type subcategorization as an additional option:

We $\left\{ \begin{array}{l} \text{allow} \\ \text{permit} \end{array} \right\}$ there to be....

Below I will discuss a verb which has three distinct subcategorizations corresponding to (1)-(3). The existence of multiple subcategorizations and lexical variation from speaker to speaker in no way diminishes the validity of

by analysis, which is based on relatively pure or paradigmatic verb-types: these may be used as coordinates to locate mixed types of verbs.

4. It should be noted that some linguists find reflexives with at least some want-type verbs to be acceptable: R. Lakoff gives (1968:71, n. 12) I wanted myself to go as a grammatical example. I will return to a possible explanation for this variation.
5. This effect could be achieved by formulating the passive transformation in such a way that it could only move an NP contiguous to V on the right, i.e., the NP in the following configuration:

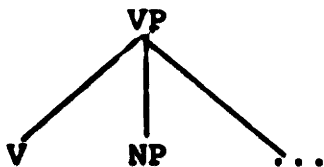

Note that (46a and b) create exactly this configuration for believe-type verbs. By contrast, the unraised NP in the complement to want-type verbs will not be subject to passivization because of the intervening for:

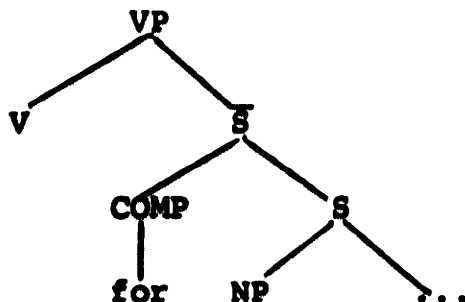

Here NP is not contiguous to V.

The existence of "double passives" is no obstacle to this formulation of the passive transformation, as we have already seen (Chapter 3, Part B, section (iii)).

6. Lakoff discusses some of the inadequacies of her analysis in n. 16. One problem not considered by her is that the particular formulation she gives, in which It Substitution optionally applies to want (p. 48), incorrectly permits the derivation of passives with want (the ungrammatical examples in (21), (28), and (29)). However, this formulation is apparently thought of as accounting for ?I want myself to go, which I find marginal.

CHAPTER 4

ON THE NATURE OF SYNTACTIC REPRESENTATION

A) Transformations vs. Phrase Structure Rules

The transformational hypothesis of complementizer insertion, as I showed in Chapter 1, fails to explain or even describe correctly many characteristics of complementizers; the various complement types are not formed by transformation but are generated by the base component. The complementizers' semantic functions, isolated in Chapter 2, make it even more obvious that these conjunctive particles cannot be dispelled from the base. In Chapter 3 I showed that two underlying sources for infinitival predicate complements must be distinguished -- the "bare S" and the for-S.

My analysis of predicate complement types thus goes squarely against a recent trend in generative grammar which would simplify the base and enrich the transformational component of grammars. Exponents of this trend often decry the use of "arbitrary subcategorization" and elaborate, language-specific phrase structure rules (of which my " $\bar{S} \rightarrow \text{COMP S}$ " would be an example, I presume). Their opponents, on the other hand, deplore their use of what might be called "arbitrary transformations" and syntactically ill-motivated

sources. But both sides agree, I am sure, that "arbitrary syntax" is to be avoided.

In the case of predicate complement types, I have tried as far as possible to eliminate recourse to exception features for transformations, or "rule features". This elimination is desirable in principle, since exception features are a mechanism for describing syntactic irregularity, or "arbitrariness" (G. Lakoff 1971). I have tried to show that much of what has been regarded as syntactic irregularity within predicate complementation is not. But it will doubtless be charged that I have only eliminated rule features at the cost of increasing subcategorization features, and thus have perpetuated "arbitrary syntax" in another guise. In principle, this is a fair criticism. But in fact, in the particular cases I have discussed, it is wrong.

The criticism would be valid if for each rule feature eliminated a corresponding subcategorization feature were added. But I have tried to show that a set of rule features, a pattern of correlated "irregularities", can be eliminated by the refinement of phrase structure rules. For example, if (1) is taken as the source of the shifting subject construction (Chapter 3,B) --

1)

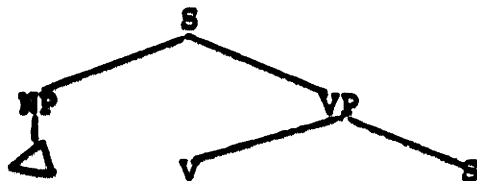

-- many apparently unrelated facts fall together; the absence of for, the absence of selectional restrictions on the subject together with the absence of sentential subjects, the impossibility of certain types of pseudo-clefts (*What seems is...) and the possibility of others (What seems to be the matter is...), the absence of a "logical subject" (evinced in *What seems?, *More is known than seems), the absence of a Fixed Subject Constraint violation. This list of "irregularities" is produced by the sentential subject analysis, and special rule features are needed to describe them. The rule feature approach fails to relate these facts; they are, however, immediate consequences of the subcategorization proposed.

Sometimes an attempt is made to describe rule feature correlations through redundancy rules. For example, it might be stated in the lexicon that all verbs which are exceptions to rule X are also exceptions to rules Y, Z, etc.; or else, all verbs having semantic or syntactic features W, X, etc., are exceptions to rules Y, Z, etc. This is a descriptive, but not an explanatory, improvement in the use of rule features. For there is no explanation why just these particular exceptions appear correlated. To see this point more clearly, consider the "redundancies" which have been used to correlate features of the subject shifting verbs: it has been proposed that the verbs which exhibit the irregularities of the above

list, such as obligatory extraposition, are the non-factive verbs having sentential subjects (Kiparsky and Kiparsky 1970); alternatively, it has been suggested that the verbs in question are just the intransitive (and perhaps also non-factive) verbs with sentential subjects (Wayles Browne, personal communication). Even if these correlations held, the approach would still fall short of explanatory adequacy: why should such verbs be irregular with respect to just these rules and not others? In fact, these proposed redundancies do not hold. Extraposition, for example, is obligatory neither in intransitive verbs nor in non-factives:

2) That the earth is flat simply doesn't follow.

That something is wrong with this analysis soon emerges when new data is considered.

That they were right { is relieving.
 stands out.
 doesn't matter.
 didn't come to light until....
 didn't come out until....
 soon became clear.

That all linguists are philosophers no longer holds.

That they were right doesn't sit well with Mr. Jones.

That the earth moves didn't register with the Church until it was too late.

For you to tell her wouldn't {work.
 help very much.

The use of subcategorization (phrase structure rules)

instead of rule features (transformations) -- in the cases I have considered -- leads to a gain in explanatory adequacy and a genuine reduction in syntactic irregularity. Of course, one wishes to avoid the proliferation of unmotivated phrase structure rules as much as the accumulation of bizarre "transformations". But some linguists have gone further to argue that there are no phrase structure rules, or rather, that there is no deep structure in the sense of Chomsky (1965).

B) The Elimination of Deep Structure and the Growth of Syntactic Irregularity

It should not be surprising that the use of rule features implies the absence of syntactic generalization -- they were devised, after all, to describe exceptions and irregularity. What is surprising is that rule features are used systematically by those who claim to have dispensed with deep structure: deep structure has been eliminated at the cost of making syntax systematically irregular.

The history of this movement towards syntactic irregularity is conveniently summarized by McCawley (1971). McCawley's aim is stated thus: "I will in fact argue that symbolic logic, subject to certain modifications, provides an appropriate system for semantic representation within the framework of transformational grammar." (p. 219)

He then goes on:

Since the representations of symbolic logic appear at first glance to be of a quite different formal nature from the labeled trees which constitute syntactic representation, one might expect that the mechanisms which link semantic representation and surface syntactic representation would divide into two separate systems, a system of 'semantic rules', which would operate on representations of the one kind, and a system of 'syntactic rules', which would operate on representations of the other kind, and that the two kinds of representation would meet at an intermediate 'level' corresponding to what Chomsky calls 'deep structure'.

McCawley then states that, "as pointed out by Lakoff..., the difference in formal nature between syntactic and semantic representation is only apparent", for the inventory of logical categories can be reduced, as can the set of syntactic categories, and a correspondence can be set up between the resulting diminished sets. In what must be regarded as a tour de force of reductivism, McCawley chronicles how the syntactic categories fell one after another; note well the use of the rule feature implicit in the concept of "triggering":

...many category differences which had figured in previous analyses have turned out to hinge merely on whether certain lexical items do or do not 'trigger' certain transformations. For example, there is no need to set up the categories Pred P [Predicate Phrase], Aux, and Modal, which appear in Chomsky (1965): one can treat the various auxiliary verbs as simply verbs [footnote omitted] which (like the verbs seem, appear, etc.) trigger a transformation of 'VP-promotion'... and which have the additional peculiarity of being combined with the tense element by a fairly early transformation.... Lakoff and Ross concluded... that the only 'deep' syntactic categories are Sentence, Noun-Phrase, Verb-Phrase, Conjunction, Noun, and Verb, and that all other traditionally recognized categories are special cases of these

categories that correspond to the 'triggering' of transformations by certain lexical items. Bach (1968) then discovered some quite convincing arguments that the Noun-Verb distinction need not be part of this inventory of categories. ...the difference between nouns and verbs is that nouns but not verbs trigger a transformation which replaces a relative clause by its predicate element. ...Lakoff observed that the resulting inventory of categories (Sentence, NP, VP, Conjunction, and "Contentive" -- the term introduced by Bach for the category containing nouns, verbs, and adjectives) matches in almost one-to-one fashion the categories of symbolic logic, the only discrepancy being that the category VP has no corresponding logical category. However, Lakoff argued, there is in fact virtually no evidence for a syntactic category of VP....

Each of the particular steps McCawley recounts is highly controversial, and I will not consider them in themselves. Together they illustrate the extended use of the exception feature. Notice how, in order to reduce auxiliaries to verbs, McCawley utilizes the analysis of seem-type verbs which I argued against in Chapter 3,B; he takes for granted that these verbs have sentential subjects and undergo a special transformation equivalent in effect to It Replacement or Pro-Substitution (p. 220); the many systematic differences between constructions must be coded in lexical items by means of rule features.

The original concept of syntactic irregularity presupposed the existence of regularity: the rule feature was intended to describe exceptions to rules. But in "the 'triggering' of transformations by certain lexical items" we now have an

enormous extension of the concept of exception feature. It is tempting to recall Frege: "The content of a concept diminishes as its extension increases; if its extension becomes all-embracing, its content must vanish altogether."

To gain the long sought-after correspondence between logical and linguistic categories, linguists of McCawley's persuasion have been willing to give up much more than the distinction between regular and irregular syntactic processes. The concept of transformation is no longer a structure dependent operation on the syntactic building-blocks of sentences. Instead, the transformation may really be just a traditional grammatical category in disguise: according to McCawley, "the difference between nouns and verbs is that nouns but not verbs trigger a transformation which...".

A further casualty in the "elimination" of deep structure is the goal of finding a theory of natural syntactic categories. The traditional syntactic categories are far from arbitrarily correlated with lexical items: not any lexical item can be an auxiliary (or, in McCawley's terms, can "trigger a transformation of 'VP-Promotion',... and ... have the additional peculiarity of being combined with the tense element by a fairly early transformation...").

Henry makes this point effectively (1971):

We should not expect to find a language with four major lexical classes -- among which concepts represented in English by nouns, verbs, adjectives

and adverbs were distributed at random, one class including, for example, words corresponding to jump, big, calmly and beetle. Obviously there must be some kind of semantic basis for every lexical class. But not every semantic notion can provide such a basis. We should be more than surprised to discover a language in which all the lexical items referring to actions, processes, entities, or qualities associated with night as opposed to day or animates as opposed to inanimates formed a single, syntactically and morphologically distinct class.

If grammatical categories -- syntactically and/or morphologically distinguishable lexical classes and structured classes of such classes -- have associated semantic functions, then they cannot be the creatures of transformation. The difference between nouns and verbs cannot be that one group triggers "a transformation which replaces a relative clause by its predicate element". Of course, with the aid of redundancy rules one could try to describe correlations between semantic classes of lexical items and transformations: all lexical items of semantic type X would "trigger" the transformations which make them behave like members of the syntactic category X' (lost with the elimination of deep structure). This approach is bound to fail, however: we may be able to find semantic functions for syntactic categories; "but," as Chomsky wrote (1957:101 n. 9), "we cannot, apparently, find semantic absolutes, known in advance of grammar, that can be used to determine the objects of grammar in any way." For example, as I noted at the end of Chapter 3,B, the modal can behaves differently from be able, the subjectless semi-auxiliary be likely

has syntactic properties quite distinct from its synonym be probable.

Worse, if deep structure is abolished and transformations are "triggered" by lexical items or semantic classes of lexical items, what is to prevent absurdities like the transformation of Red Extraposition? Red Extraposition is a transformation which is triggered by lexical items which have "red" as part of their meaning; it extraposes these items. A grossly oversimplified schematic illustration of its effects is given in (3):

- 3) The red book is on the table.
 The wind burned the faces of the skiers.
 The blushing boys were sent to the corner.
 Crimson is my favorite color.
 The gore dripped from his hands.
-

The point is that a grammar of the type McCawley proposes does not distinguish human languages from languages exhibiting such wonders as Red Extraposition.

C) Complementizers and Deep Structure

As we have seen, the use of phrase structure rules and syntactic subcategorization is hardly arbitrary. Although some linguists claim to reduce syntactic structure to "logical structure", eliminating deep structure in Chomsky's sense, the anfractuous path that must be taken back from

this logical basis to surface structure justly deserves the title "arbitrary syntax". The loss of the essential distinction between regular syntactic processes and exceptions, the attenuation of the concept of transformation, and the abandonment of the goal of finding a theory of syntactic categories are direct consequences of the elimination of deep structure.

Apart from these theoretical consequences, the elimination of deep structure would have quite particular effects in each language. In English, as we saw, there are syntactic generalizations in the paradigmatic differences between seem and possible or believe and want: these differences are not irregularities or accidents, but reflect significant underlying syntactic differences.

The clause-particles called complementizers provide an especially interesting means of examining the nature of syntactic representation. As I have observed several times, many linguists assumed that they were meaningless syntactic markers. There are a number of reasons for this assumption. First, the syntactic similarities between WH, or "Q", and the recognized complementizers that and for were overlooked. Second, if WH, which obviously has a semantic function, is not considered a complementizer, one is left with only that and for. But for was assumed to occur with all infinitival predicate complements -- with

seem as well as possible, believe as well as want. Thus it is not surprising that a semantic function of for was not noticed.

Even Kiparsky and Kiparsky (1970), who argued that syntactic phenomena reflect deep semantic facts and who explicitly rejected the assumption that all infinitival complements stem from the "for-to" marker, failed to inquire into the inherent meaning of for. Instead, they expressed their insights in terms of semantic classes of predicates

(p. 169):

The class of predicates taking emotive complements ...includes in general all predicates which express the subjective value of a proposition rather than knowledge about it or its truth value. It is this class of predicates to which for-to complements are limited.

They thus leave unexplained the question why for should be limited to emotive predicates. This emphasis on predicates reflects a third reason for the assumption that complementizers are arbitrary markers: the tacit assumption that only "predicates" bear meaning. Of course, in the complex, highly articulated structures of natural languages, tense, mood, quantifiers, articles, prepositions, nouns, adverbs, and conjunctions are all meaningful. But with the aid of increasingly powerful syntactic devices, such as the rule feature, all of these could be reduced to "predicates": it was claimed that tenses are predicates at the deepest level of language and that not is a verb (McCawley 1971): it was argued that English

modals are really verbs, hence predicates (Ross 1971); it was urged that quantifiers be regarded as predicates (Lakoff 1970); it was suggested that prepositions are predicates (Langendoen 1971); it was proposed that ordinary nouns derive from underlying predicates (Bach 1968); adverbs were often derived from periphrastic sources; it was claimed that coordinate conjunctions are predicates (McCawley 1971). This reduction produced basic linguistic structures which were very remote from surface structure but close to simple "logical" representations of meaning. Those grammatical items which were obviously not predicates, such as complementizers, were regarded as meaningless markers inserted by transformation.

Still another reason for regarding complementizers as meaningless comes from the practice of describing "constructional meaning" by means of paraphrase rather than interpretation. For example, the interpretation of a sentence having a for complement depends on the meaning of for combined with the meanings of the main verb, auxiliaries, and other factors; the interpretations may have widely varying paraphrases in terms of if, when, whenever, that, and "subjunctive" that, or even -ing (see Chapter 2). If the varying interpretations were derived transformationally from such paraphrase sources, it would become accidental that for occurs in all of the derivations, and inexplicable why some predicates exclude for: for

example, if (4a) is the source of (4b), why isn't (5a) a source of (5b)?

- 4) a. It would be dreadful if Valerie tried it.
 b. It would be dreadful for Valerie to try it.
- 5) a. It would be apparent if Valerie tried it.
 b. #It would be apparent for Valerie to try it.

The syntactic and semantic correspondences between such putative sources and their "transforms" are in any case too inexact to provide either an accurate description or a satisfying explanation of the range of properties of for complements.

In sum, each of these reasons for assuming that complementizers are meaningless markers is unwarranted: WH does behave like a complementizer (Chapter 1); for is not the source of all infinitives (Chapter 3); complementizers (as well as "predicates") bear meaning (Chapter 2); and the range of meanings of the complements reflects semantic composition rather than derivation from distinct paraphrase sources. How, then, are these meaningful particles to be represented in a grammar of English, if deep structure has been eliminated?

Those linguists who advocate treating conjunctions as predicates might suggest that the complementizers are also predicates of sentences, perhaps adding that WH is a relation between a sentence and one or more terms.

This step would provide an elegant uniformity of terminology -- at the cost of syntactic generalization. For consider the obvious fact that the complementizers are mutually exclusive occupants of clause-initial position, which is captured with the phrase structure rule $\bar{S} \rightarrow \text{COMP } S$: where is this to be stated in the grammar? It is clearly a linguistically significant generalization (cf. Chapter 1). One might hope that this fact about complementizers would follow from some aspect of their analysis as "predicates", such as McCawley's proposal (1970) that English is a VSO, or predicate-initial, language. It seems initially plausible that if predicates are initial in English underlying representation and complementizers are predicates, then the initial position of complementizers merely reflects the underlying position of predicates; we might be encouraged in this supposition by observing that Japanese, which is verb-final, has clause-final particles. However, the notion of predicate position is simply too weak to yield any explanation for COMP position. Virtually everything is a "predicate" in logical structure, but winds up in the course of a derivation in a characteristically different place. Hence the mapping from underlying predicate position to deep structure or "shallow structure" position is one-many. It follows that there is no way of capturing the generalization $\bar{S} \rightarrow \text{COMP } S$ in "logical structure". It is a mere

accident that COMP and V are not systematically interchanged.

Nor is surface structure a likely place to characterize the peculiar properties of predicates like that, for, and WH. To my knowledge, no one has proposed a surface structure constraint of the kind needed. It would have to distinguish between [the men she saw] [that she liked] and *[the men she saw that] [she liked]; it would have to allow It would be strange for Kip and for Mary both to fly to N.Y. as well as Tom refused to say why, or even whether, he did it.; but it should rule out *Whether are you leaving? in the face of Why are you leaving?; and it would have to discriminate among That he's leaving we already know (Topicalization), He's leaving, you know (Parenthetical), *That he's leaving, you know (Parenthetical). The only surface structure constraints which have been very well motivated for any type of phenomena have been highly restricted formally, such as the restrictions on clitic order, which appear to be word-formation stencils (Parlmutter 1971).

Thus the generalization $\bar{S} \rightarrow \text{COMP S}$ must be captured at some point in the derivation between "logical structure" and surface structure. Whether the term "deep" or "shallow" is used to apply to this level of structure is of no theoretical consequence whatsoever.

D) On the Syntactic Representation of Comparatives

Complementizers exist in deep structure in the sense that there is a phrase structure rule $\bar{S} \rightarrow \text{COMP } S$, where COMP may be WH (the interrogative complementizer), for, or that. In Chapter 5 the notion of "English complementizer" is extended to than and as as well. That is, an analysis of certain basic comparative constructions is presented in which than and as play a role exactly analogous to the role of that in relative constructions: we have a 1-1 correspondence in deep structure between the relative and comparative clause, with the relative having a noun as head and the comparative having an adjective as head. This correspondence is apparent in the surface structures of (1), which are only approximately represented:

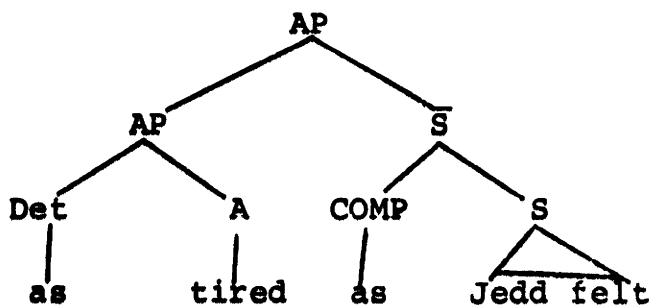
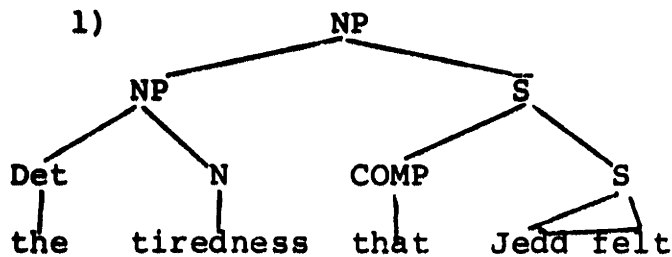

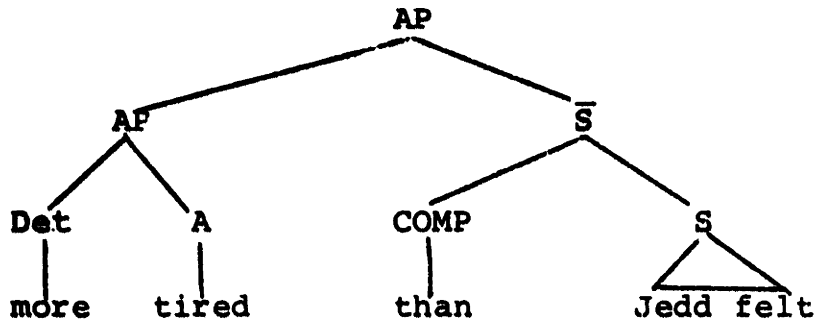

The structures represented in (1) would appear in contexts like the following:

- 2) The tiredness that Jedd felt at such times was understandable.

It began as a tiredness that Jedd felt at faculty meetings.

Could they be as tired as Jedd felt?

His friends seemed tired to Jedd, even more tired than Jedd felt.

So far it is only important to note that on this analysis the comparative and relative clauses are structures dominated by AP and NP in deep structure. But any such subordinate origin for comparatives is explicitly criticized by Ross and Perlmutter in a note entitled "A Non-Source for Comparatives" (1970). Therefore, it is necessary to show here that their data do not establish their conclusion; in fact, the evidence suggests a conclusion opposite to the one they draw.

In Foss and Perlmutter (1970) it is pointed out that a

sentence like

3) Bill thinks that he is taller than he is.
has a reading paraphrasable by

4) The height Bill thinks he has exceeds the height
he (actually) has.

It is asserted that this reading "cannot be plausibly derived from any deep structure" in which the comparative clause than he is is subordinate to the verb think. The reason for this assertion is that the "than-clause of [3], superficially a part of the object of think, must appear outside the object of think in underlying structure if the reading of [3] that is roughly paraphrased by [4] is to be accounted for." Before examining this reason, I would like to note here that an ordinary relative clause may exhibit the same property as the comparative in (3): the sentence

5) Bill thinks that he is someone that he isn't.
has a reading paraphrasable by

b) The person Bill thinks he is is not the person
that he (actually) is.

Indeed, a non-clausal object of think has a similar property; so that the sentence

7) Bill is thinking of Aristotle.
may be paraphrased as

8) The person Bill is thinking of is (actually)
Aristotle.

(7) and (8) may be used to mean that Bill is thinking of

someone he does not know or remember the name of, but whom the speaker knows to be Aristotle. Hence by parity of reasoning one could conclude that the relative clause in (5) and Aristotle in (7) must appear outside the object of think in underlying structure "if the reading... is to be accounted for". In other words, to account for the semantic fact that embedded material is often understood as the speaker's interpolation, the interpolated material is represented as lying outside the complement in underlying structure. Then a transformation is devised to insert this material into the complement. This kind of reasoning is obviously relying on several unstated assumptions, one of which is that the interpretations of the sentences given must be represented by distinct deep structure configurations.¹

What is needed is independent syntactic justification for the gross syntactic deformations implied by this assumption. Otherwise the new representation, attractive though it may seem, explains nothing: it merely redescribes an observed fact. What would be of interest is independent syntactic evidence supporting these proposals. Ross and Perlmutter claim to present two such facts for comparatives.

The first fact is that "tenses can show up in the than-clause that cannot appear in the object of think", for

example

- 9) a. I thought that I was tall.
 b. *I thought that I am tall.
- 10) a. Bill thought that he was taller than he was.
 b. Bill thought that he was taller than he is.

From this it is inferred that "the than-clause is not in [n.b.] the object of think at whatever stage in derivations the condition on possible sequences of tenses is stated". But from (9) and (10) one can infer only that the than-clause is not identical with the object of think, a rather trivial result. Ross and Perlmutter's conclusion would follow if it were generally true that clauses contained in complements do not permit free tense. But this is not the case: it is false for relative clauses:

- 11) I thought I was the one who is tall.
 Bess thought that she was the one who is wanted for murder.
 Bess thought that you were the kind of man that you aren't.

-- it is false for NP complements:

- 12) Bess thought that I verified your claim that she is tall.
 Bess thought that everyone rejected her view that analysis precedes action.

-- it is false for AP complements:

- 13) Bess thought our proposal was so absurd that we have to revise it.

Bess thought that her invention was so clever
that she is flying to Washington, D.C.

-- and it is false for so-called than and as relatives:

14) Bill thought that his daughter married as
smart a man as he is.

Bill thought that he was no more violent a man
than Richard is.

If an external source really were the explanation for the
difference between (9) and (10), then Ross and Perlmutter
would be forced to posit an external source for (11)-
(14) as well. This position will be seen to be incon-
sistent with the second fact presented by Ross and Perl-
mutter. As an alternative account of (9)-(14), let us
suppose that the past tense agreement of a subordinate
clause with the main clause is optional when the subordi-
nate clause has a head; in other words, "headed" clauses
are domains which may be impervious to tense agreement.
This assumption obviously accounts for (11)-(14), if one,
kind, claim, view, absurd, clever, smart (a man), violent
(a man) are taken as the respective heads of the appro-
priate clauses. The same assumption, together with the
deep structure isomorphism between comparatives and
relatives sketched at the outset, predicts (10).

The second fact presented as evidence against the subordi-

nate origin of comparatives is that parentheticals "which cannot generally occur in embedded complements can occur in than-clauses"; for example²

15) *Bill thinks that Jane, it seems to me, is tall.

16) Bill thinks that he is taller than Jane, it seems to me, has ever been.

This statement is misleading, since such parentheticals are common in relative clauses:

17) They think that Tom is someone that, it seems to me, he isn't.

If there is a structural reason for (17), then the isomorphism between comparatives and relatives would lead one to predict the possibility of (16). By contrast, Ross and Perlmutter might seek to explain (16) and (17) by claiming that relative as well as comparative clauses originate outside the complement. That is, they might argue that parentheticals generally occur in nonembedded clauses and that therefore relatives, as well as comparatives, are nonembedded. A stronger argument can be made against this position than the observation that there is no evidence for it. Consider the following:

18) *I verified your claim that Bill, it seems, is tall.

The presence of parentheticals clearly distinguishes relative clauses from complement clauses: complement clauses, as (18) show, prohibit parentheticals. The noun phrase in (19)

19) the idea that Bess was the first to publish
 may mean "the idea which Bess was the first to publish"
 or "the idea that Bess was the first to publish something",
 but the noun phrase in (20) has the former meaning only:

20) the idea that Bess, it seems to me, was the
 first to publish

Thus NP complements permit free tense (see (12)) but prohibit parentheticals. To explain this fact Ross and Perlmutter must claim either that free tense is a property of all but not only nonembedded clauses or that the tolerance of parentheticals is a property of only but not all nonembedded clauses. The former alternative destroys the tense evidence for an external source for comparatives. The second alternative is false. All known nonembedded clauses permit parentheticals, including negatives (He didn't come, I don't think), imperatives (Remember to drink your milk, I say! Drink your milk, I beg of you!), questions (Is she right, do you think?), and more to the point, coordinates (Bess left and Helen, I think, stayed).³

Thus the only way left of retaining the hypothesis that comparatives originate outside the complement in which they are embedded in surface structure is to admit that free tense is not evidence, to assert that all and only nonembedded clauses permit parentheticals, and to claim that relative clauses, too, originate outside the complement in which they are embedded.

The case for the external origin of comparatives therefore rests on the external origin of relatives. But any proposal for deriving relatives externally faces insurmountable obstacles. For example, the proposal in Annear (1967) would derive (21) from (22):

21) A lady that I met downtown today spoke to me
in Mundari.

22) I met a lady downtown today and she spoke to me
in Mundari.

But the negation of (22) is not equivalent to the negation of (21): Either I didn't meet a lady downtown today or she didn't speak to me in Mundari does not mean the same as It's not the case that a lady that I met downtown spoke to me in Mundari. It is important to recognize that this nonequivalence is essential to any account which attempts to derive a subordinate relation from a coordinate relation, or vice versa, for logical negation does not distribute over subordinators. This fact is traditional knowledge.

Further, there is no corresponding way to derive (23) under the nonspecific reading (where any Mundari-speaking lady will do):

23) I am looking for a lady who speaks Mundari.

(23) is not synonymous with (24) or (25):

24) A lady₁ speaks Mundari and I am looking for a
lady₁/her₁.

- 25) Some ladies speak Mundari and I am looking for one.

Note that one could add although there may not be such a lady to (23) but not to (24) or (25). Nor can one derive a sentence like (26) in a parallel way when it is construable as a remark about Kepler:

- 26) Whoever discovered the elliptic form of the planetary orbits died in misery.

This example, which was devised by Prage, is not synonymous with

- 27) If anyone discovered the elliptic form of the planetary orbits, he died in misery.

-- nor could it come from a conjunction like (28)

- 28) Someone discovered the elliptic form of the planetary orbits and he died in misery.

For the negation of (28) is not equivalent to the negation of (26), as Frege pointed out.

In conclusion, there is no syntactic evidence for an external origin for comparatives. The syntactic data Ross and Perlmutter give support an alternative analysis, as shown, and their semantic observation remains just that. There is a very general semantic phenomenon permitting parts of sentences to be interpreted as originating with the speaker or with someone mentioned by him; this may require an interpretive explanation rather than a

revision of the base rules for comparatives, relatives, simple objects, and whatever other constituents permit semantic "interpolation".⁴ Finally, it is worth pointing out that if Ross and Perlmutter's hypothesis were correct, the striking surface isomorphism illustrated in (1) would have no explanation. A theory in which comparative or relative clauses come from an external source by means of transformations makes of such formal syntactic regularities a series of accidents.

FOOTNOTES

CHAPTER 4

1. Another assumption, of course, is that transformations may be defined to carry out the necessary formal operations on trees. Recent work (Hasegawa 1968; Emonds 1970; Hasegawa 1972) indicates that the kinds of interpolating transformations needed do not satisfy independently motivated empirical constraints.
2. (15) and (16) are Ross and Perlmutter's examples; though to some, sentence (16) may sound odd, I think that Ross and Perlmutter's observation is correct: cf. Bill is stranger than Mary, I suspect, realizes; Women are smarter than men, I believe, are ready to admit.
3. This fact was pointed out to me by Karin Aijmer.
4. A detailed interpretive solution to this problem is set forth by Hasegawa (1972).

CHAPTER 5

EXTENDING THE INVENTORY OF COMPLEMENTIZERS

A) Introduction

The grammatical functions of the complement types discussed so far (Chapters 1-3) are quite different from those of the comparative and relative clauses. Predicate complements can function as terms; for example, they may be subjects or objects to a given predicate. But the relative or comparative clause bears an entirely different kind of grammatical relation to the sentence: it determines or characterizes some given term of the sentence. Viewed semantically, the head of a comparative or relative clause construction seems to contain an operator which binds an element of the clause:

- 1) all that he needed
(all x) (that he needed x)
- 2) more than he needed
(more x) (than he needed x)

While a predicate can map terms into a sentence, an operator can map a sentence into a term, so to speak.

Certain distinguishing properties of comparative and relative clauses follow from their semantic function. For example, in deep structure some part of the clause

must be "bindable" to the head -- identical or in anaphoric relation to it; otherwise the construction will be ill-formed. Thus we have all that he kept, more (things) than he kept, but not *all that he slept, *more (things) than he slept, because in the latter cases the clauses lack a bindable term: *he slept things.

Notwithstanding the distinctive grammatical function of comparative and relative clauses, their internal syntactic structure is similar to that of the predicate complement types -- an S prefixed by a "conjunctive particle" such as than, as, that. Whereas the predicate governs (in part) the choice of particle in the predicate complement, the determiner governs (in part) the comparative or relative particle. (See Selkirk 1970; Bowers 1970). If, then, we speak of "predicate complementation", it is no less appropriate to speak of "determiner complementation".

The theory of complementation includes the study of both predicate and determiner complementation. I have already remarked on certain generalizations over both structures: the Complementizer Attraction Universal (Chapter 1) relates the position of "conjunctive particles" to the possibility of certain kinds of transformations affecting both predicate complements (Wh type) and determiner complements (relative type); another universal (Chapter 1) relates position of COMP in \bar{S} to the ordering of head

and \bar{S} so that COMP intervenes between the head and its relative clause; the semantic functions of the predicate complementizers appear to generalize over relative clause types to explain several oddities of that construction (Chapter 2).

In these statements I have assumed that the relative clause may be introduced by a conjunctive particle occupying COMP position, in other words, that the relative clause has the internal structure provided by the rule $\bar{S} \rightarrow \text{COMP } \bar{S}$. This rule, together with the hypothesis that the particles introducing comparative and relative clause types (than, as, that, for) are members of COMP, yields an explanation for the fact that these particles are clause-initial in English. Indeed, the general theory of complementation may be strengthened to explain why, in languages having clausal comparatives, the comparative "particle" appears to occur in the clause (initially or finally) where the other complementizers occur; and in particular, why relative and comparative complementizers seem not to diverge in position.¹

Recall that by recognizing the WH complement as an \bar{S} , one can explain the fact that English has only one of the following possibilities for positioning WH and that:

- 3) a. that S
 WH S

- b. that S
S WH
- c. S that
WH S
- d. S that
S WH

In just the same way we see that the positioning of as, than is not arbitrary: in fact, if this thesis is correct, the choice of possibilities in (4) is predictable from the choice in (3):

- 4. a. the decision that he made { that S }
as decisive as he seemed { as S }
more decisive than he seemed { than S }
- b. the decision that he made { that S }
as decisive he seemed as { S as }
more decisive he seemed than { S than }
- c. the decision he made that { S that }
as decisive as he seemed { as S }
more decisive than he seemed { than S }
- d. the decision he made that { S that }
as decisive he seemed as { S as }
more decisive he seemed than { S than }

In other words, if only (3a) is grammatical, then only (4a) is grammatical: this fact follows immediately, provided that the rule $\bar{S} \rightarrow \text{COMP S}$ exists and that COMP includes that, WH, than, as.

Two further consequences can be drawn from the hypothesis that the determiner complement types are isomorphic to the predicate complement types: both proposed universals of Chapter 1 can be generalized to comparative clauses.

As particular instances of these extended universals, we would have

- 5) Only COMP-initial languages permit the attraction of elements to the conjunctive particle of comparative clauses (than, as in English).
- 6) Languages with head-initial comparative clauses are COMP-initial languages; the COMP intervenes between head and clause in comparatives as well as relatives.

(5) means that "relative pronoun" movement in comparatives can occur only under the same conditions as relative movement and question movement -- in COMP-initial languages. (6) means that of the logically possible orderings of, say, adjectival comparatives -- A S COMP, COMP S A, S COM. A, and A COMP S -- only the latter two are "natural" possibilities for human languages. (Note that I am speaking only of clausal comparatives; nonclausal types of comparative constructions, involving prepositional phrases or verbs, are excluded.)

Further research is needed to determine whether (5) and (6) hold generally. Both of them have interesting illustrations in English. Regarding (5), I quote Jespersen (MEG III.9.6₂):

Vulgar speech has a redundant combination with what: Shaw...you're nearer my age than what he is. Higgins (gently) Than he is: not "than what he is". Thus also Mackenzie...I'm more in earnest

than what you are...I hope you can walk quicker than what you eat. Similarly with as...they're just as quick with their tongues as what you are ...I'm not near so deep as what you are.

Note especially that the what phrase in these examples is not a free relative: in I hope you can walk quicker than what you eat what is meant is "I hope you can walk more quickly than you eat" and not "I hope you can walk more quickly than the things you eat can walk (e.g. lobsters)". This "relative pronoun" what is attracted to initial position in these comparatives, as (5) would lead us to expect. If (5) is correct, it should turn out that no COMP-final language has a similar movement rule operating in comparative clauses.

The order of clause and head in English comparatives illustrates (6). Because the COMP must fall between the head and clause, and because English is COMP-initial, we have the order HEAD { than / as } S. At first sight it may appear that a phrase like more than 2' tall is a counterexample, because the than-phrase precedes the adjective; however, I will establish in section (B) of this chapter that the true head of this construction is the quantifier-like -er much [more], which may modify both nouns and adjectives. A genuine counterexample to (6) would be a case where a COMP-final language having a clausal comparative construction ordered the clause after the head: HEAD S COMP; (6) predicts that the order should be

S COMP HEAD, just as in the case of the relative clause construction. We should not expect to find (7b) or (7c) in a language, except possibly in the extraordinary situation where one construction had been borrowed from a language of the opposite type in COMP-position:

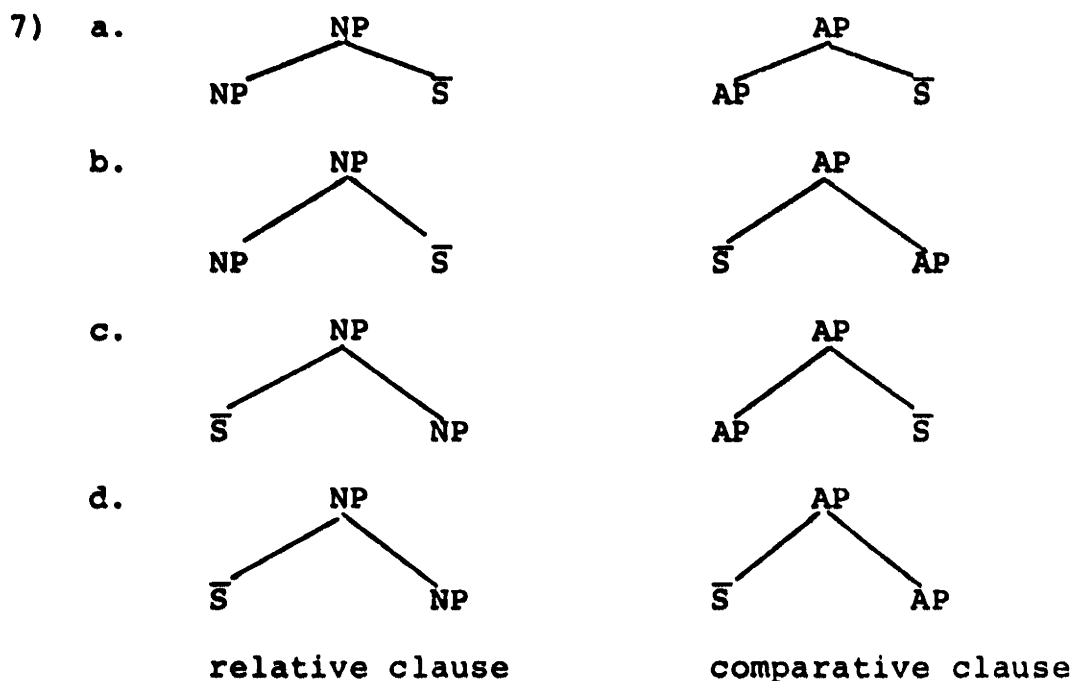

My view that the theory of complementation includes both predicate and determiner complement types, that these are syntactically of the same form (COMP S), is not new.

Jespersen (MEG III. 8,9) stated a quite similar view, one which he reports (8.7₆) that he held in a publication in his undergraduate days (1885). He sums up his view on relative that (8.7₅):

We have thus brought together a great many phenomena, which traditional grammar puts into various separate pigeon holes, though they are in reality identical means of connecting a clause with the rest of the sentence, either without any form word or with the empty and therefore in many cases superfluous particle that. We may even say that in I know you mentioned the man,

and in I know the man you mentioned we have clauses with direct contact, and in I know that you mentioned the man, and in I know the man that you mentioned, we have the same kind of clauses with mediate contact, that being used to cement the two closely connected parts of the sentence.

The view that than and as in comparatives are parallel to that in relatives was also held by Jespersen, who used the terms "relative that" and "relative as, than, but" as chapter headings in MEG III. (The relative use of but occurs in such examples as I see none but are shipwrecked, meaning, approximately, "I see only ones that are shipwrecked". This complementizer has some fascinating properties, but I am neglecting it because it is unfamiliar to me, and may be obsolete.) Jespersen observes, "The conjunction of comparison as often serves to introduce clauses which must be termed relative. Many grammarians then call as a relative pronoun...." (9.1₁) The examples he gives include those in (8):

- 8) such women as knew Tom
 such women as Tom knew
 such women as Tom dreamt of
 more women than ever came here
 more women than he had seen there
 more women than he dreamt of

Then he continues:

It seems, however, hardly natural to extend the name of pronoun to all these cases. After what was said above (8.7₅) [quoted above] on that it

will not surprise my readers if I prefer using the term particle or conjunction in speaking of as, than, and but in these employments, exactly as in other uses of the same words. This puts all the clauses here mentioned on the same footing and also approximates them to contact-clauses [e.g., I know you mentioned the man; the man you mentioned]. If it is asked what then is the subject of the verb in "such women as knew Tom" and "more women than ever came here" and "there are no women but admire him", the answer must be that there is no subject in these clauses, and that there is the same lack of a subject in "all the women that admire him" and in "there's a man below wants to speak to you". In the same way there is no object in the other clauses. Nothing is gained in such cases by putting up fictitious subjects and objects [i.e., as, than that as "pronominal" subjects and objects]: it is much better to face the simple truth that there are clauses without a subject and others without an object, just as there are sentences without either.

Later Jespersen cites an example of than and that clauses conjoined, where that has been deleted (9.6₁):

- 9) to tell Mr. Stead all, and perhaps more than,
he cares to know

I find the following equally grammatical:

- 10) tell him almost as much as, but certainly not
all (that), he'd like to know
tell him all that, and perhaps more than, he'd
like to know
tell him no more than, nor even all (that),
he'd like to know

Coordinated relatives and comparatives are reducible in this way because of their structural similarity: the underlying heads all and much are conjoinable ("he knows much but not all") and the common part, dominated by S, may be

factored out. The comparative and relative are truly parallel structures.

B) On Comparatives

(1)

Syntax of the Head

In this section I will argue that underlying every comparative is a partitive or quantifier-like element much, many, little, or few. This point has been assumed by some linguists (e.g. Hale 1971) and rejected by others (e.g. Selkirk 1970). However, there is compelling syntactic evidence that the comparatives in (1) derive from sources in (2):

- 1) a. She has more independence.
- b. She is happier
- 2) a. [[-er much] independence]
- b. [[-er much] happy]

On the face of it, it may seem odd to propose that partitives or quantifiers occur on adjectives and adverbs as well as nouns. After all, there are apparently no examples like (3b) to match (3a):

- 3) a. They think she has too much independence.
- . b. *They think she is too much happy.

Nevertheless, this is a case where surface structure obscures a deep structure regularity. A closer examination

of surface structure evidence will reveal that (3b) does occur at a stage in the derivation of a grammatical sentence.

(1) more < er much or er many

Many have suggested that more is not really just more, but the comparative of much and many, specifically that more < er much or er many.¹ Consider the following paradigms:

| | | | | | | |
|----|------|------|---------|------|--------|---------|
| 4) | as | much | bread | as | little | bread |
| | too | " | " | too | " | " |
| | that | " | " | that | " | " |
| | so | " | " | so | " | " |
| | -er | " | " | -er | " | " |
| | | | [>more] | | | [>less] |

| | | | | | | |
|----|------|------|---------|------|-----|----------|
| 5) | as | many | people | as | few | people |
| | too | " | " | too | " | " |
| | that | " | " | that | " | " |
| | so | " | " | so | " | " |
| | -er | " | " | -er | " | " |
| | | | [>more] | | | [>fewer] |

By supposing that much and many underlie more (and that little underlies less)², we can account for the gaps in paradigms (4) and (5): instead of *mucher bread, *littler bread, *manier people, corresponding to fewer people, we have more bread, less bread, more people. Let us then hypothesize the following structure:

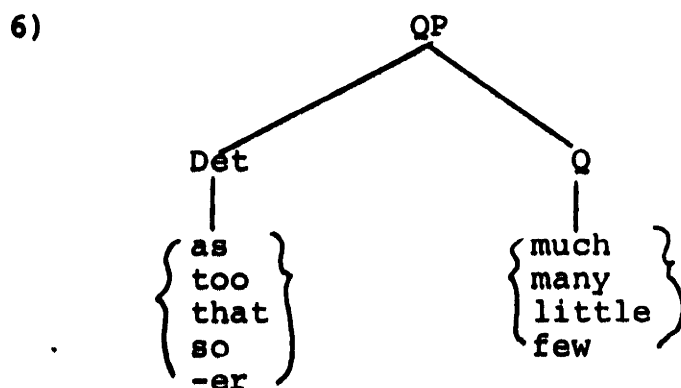

The label "QP" is merely a temporary convenience: further research on partitives, quantifiers, and adverbs will be

necessary to determine the kinds of categories involved.

We will also need rules to accomplish the changes indicated in (7):

- 7) -er much → more
- er many → more
- er little → less

The item much, for example, can be lexically inserted into Q and can have a number of determiners, as shown. This proposal would explain the impossibility of *as more, *too more, *that more, *so more, and *as less, *too less, *that less, *so less.

One obvious difficulty with this proposal is that more can appear in surface structure where much cannot, namely, before adjectives and adverbs:³

- 8) Mary is $\left\{ \begin{array}{l} \text{more} \\ *so\ much \end{array} \right\}$ intelligent.
- 9) Mary speaks $\left\{ \begin{array}{l} \text{more} \\ *so\ much \end{array} \right\}$ cogently.

Here one is faced with several alternatives:

- a) more does not derive from er much, er many; or it derives from these forms everywhere except before adjectives and adverbs.
- b) more does derive from er much, er many everywhere in deep structure, but there is a rule deleting much obligatorily when it modifies adjectives and adverbs.

At this point it is hard to decide which alternative is correct, but there is evidence favoring (b).⁴

Hypothesis (b) requires a rule which I will write as

- 10) $\text{much} \rightarrow \emptyset / [\dots ___ A \text{ AP}]$, where A(P) = Adjective or
Adverb (Phrase)

By virtue of (10) we have

- 11) *as much tall \rightarrow as tall

but

- 12) I drank as much milk $\not\rightarrow$ *I drank as milk.

- 13) I ate as much $\not\rightarrow$ *I ate as.

Rule (10) does go beyond the facts of (11)-(13); it predicts that much will remain everywhere except directly before A. And indeed, we find that much remains before a compared A. Thus we have much deletion only in the first of each of the following three pairs of examples:

- 14) *as much intelligent \rightarrow as intelligent
 15) as much more intelligent $\not\rightarrow$ *as more intelligent
 16) *as much clearly \rightarrow as clearly
 17) as much more clearly $\not\rightarrow$ *as more clearly
 18) *as much tall \rightarrow as tall
 19) as much taller $\not\rightarrow$ *as taller

(From (19) together with (10) we may infer that taller < more tall.)

The rule deleting much (10) must follow the formation of more from er much. This formation may be represented

informally by (20):

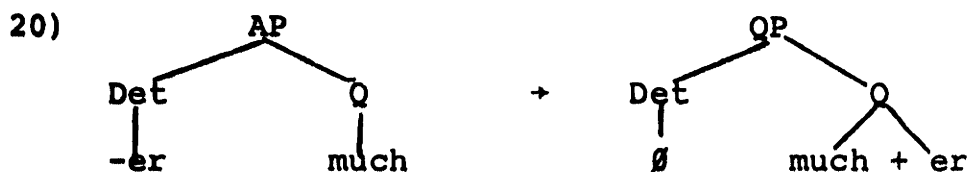

In other words, $-\text{er Q} \rightarrow \text{Q } -\text{er}$. (A later rule of suppletion will substitute more for much-er.) Since the -er suffix intervenes between much and the following adjective or adverb, the much-deletion rule (10) will not apply to the output of rule (20). Thus the contrast between *as much intelligent and more intelligent [<er much intelligent] is caused by the fact that -er encliticizes upon much, thus preventing its deletion, while as remains in the Det.

Rule (20) will also apply when many, few, and little occupy Q.

The following parallel derivations summarize the main features of the analysis so far:

| | | | | |
|-----|----|--------------------------------------|---------------------------------|--------------|
| 20) | a. | [[<u>-er much</u>] tall] | [[<u>as much</u>]tall] | |
| | b. | [[\emptyset <u>much-er</u>]tall] | n.a. | rule 20 |
| | c. | n.a. | [[<u>as</u> \emptyset]tall] | rule 10 |
| | d. | [[<u>much-er</u>]tall-er] | n.a. | rules for |
| | | [\emptyset tall-er] | | simple |
| | | | | comparatives |

The underlying Q modifying an adjective (or adverb) remains when anything intervenes between it and the A; the -er suffix placed in (21b) thus serves to protect much from

deletion in (21c). I derive the simple comparative form shown by some adjectives (taller) from the compound form, approximately as shown.⁵

The claims that much deletes directly before an A and that the simple comparative (A-er) derives from the compound (more A) find direct support in the following examples:

- 22) a. John is more than 6' tall.
 b. John is taller than 6'.
 23) a. These plants may grow as much as 6' high.
 b. These plants may grow as high as 6'.

Examples like (22) and (23) are analyzed in detail in part (ii) on the syntax of the clause. Here we can observe that when the than or as phrase precedes the adjective, the Q is not deleted -- whether by much deletion (rule 10) or by simple comparative formation (21d). But when the phrases follow the adjective, these processes take place as usual.

Once we admit that adjectives and adverbs, like nouns, can be modified by the partitive-quantifier QP, a number of other facts fall together. Many other quantity indicators modify both adjectives and nouns:

- 24) a. a bit long a bit of rope
 b. an inch long an inch of rope
 c. long enough enough rope

In the next two sections, I argue that enough has the same

distribution as the QP more, and ought indeed to be analyzed as a "Q".

(2) more and enough

Let us begin by comparing the overall distribution of more and enough. By themselves these words often appear in place of NP's, functioning as subjects of objects:⁶

- 25) More has happened in the last week than will happen in the next year.
- 26) He offers more than we had hoped for.
- 27) He was hoping for more than we offered.
- 28) Enough is going on to keep them confused.
- 29) You've said enough to convince me.
- 30) I've thought about enough for twelve to think about.

Both words also appear in place of adverbs:

- 31) Sally eats caviar more than I had expected.
- 32) Susan doesn't eat her vegetables enough.

In (31) and (32) more and enough are rather like other post-object adverbs;⁷ compare (34), (36), and (37):

- 33) Sally eats the stuff pretty often.
- 34) *Sally eats pretty often the stuff.
- 35) Sally eats the stuff more.
- 36) *Sally eats more the stuff.
- 37) *Susan doesn't eat enough her vegetables.

The following sentences are ambiguous between the adverbial and substantival uses of more and enough:

38) John eats more.

39) John doesn't eat enough.

(38), for example, may mean either "John eats a greater amount" or "John eats to a greater extent or degree" according as more is the direct object of eat or its adverbial modifier. Often a than clause disambiguates such sentences:

40) John eats more than he pays for.

41) John eats more than he sleeps.

In (40) the amount John eats is compared to the amount which he pays for; in (41) the degree or extent to which John eats is compared to the degree or extent to which he sleeps.⁸

In addition, more and enough can function as partitive quantifiers, appearing with both prepositional phrase (PP) and NP structures:

42) He gave me more of his marbles than I wanted.

43) There is enough of the bread left to have tomorrow.

44) He gave me more marbles than I wanted.

45) There is enough bread for all of you.

46) There is bread enough for all of you.

An NP follows more and enough without an intervening of when the NP has an empty Determiner, as when it contains a mass or indefinite plural noun; thus (48)-(50) in the following set are ungrammatical because problem is a count noun.

47) She has enough of a problem as it is.

48) *She has enough a problem as it is.

49) *She has enough problem as it is.

50) *She has problem enough as it is.

Contrast (47)-(50) with (51)-(53):

51) *She has enough of problems as it is.

52) She has enough problems as it is.

53) She has problems enough as it is.

To account for (47), (48) vs. (51), (52) we can hypothesize a rule to insert of between a "Q" and a Det in a NP:⁹

54) $\emptyset \rightarrow \text{of} / \text{Q} ___ \text{Det N}$

If (54) is correct, then more egg, more of an egg, enough egg, enough of an egg, more eggs, more of the eggs, enough eggs, enough of the eggs all have isomorphic underlying representations, their surface differences being traceable to the nature of the determiner of egg(s).

Besides functioning as substantives, adverbs, and quantifiers, more and enough occur as adverbial modifiers of adjectives and adverbs:

55) He looks more formidable than he is.

56) *He seems enough intelligent for you.

57) He seems intelligent enough for you.

58) She writes more clearly than she speaks.

59) *She speaks enough clearly to be understood.

60) She speaks clearly enough to be understood.

Occurring adverbially, as in the grammatical members of

(55)-(60) or examples (31) and (32), more and enough signify degree or extent; in their occurrences as substantives and partitives, they signify amount. There is yet another construction in which more and enough occur; this curious construction is isomorphic to the partitive constructions (42), (43), but more and enough signify degree or extent rather than amount:

61) I'm more of a man than you are, my dear.

62) He's enough of a fool to try it.

63) He's fool enough to try it.

Contrast (61) and (62) with true partitive constructions:

64) I saw more of the man than you did.

65) I saw enough of the fool to be convinced.

((64) and (65) are ambiguous in the same way as to see a lot of someone, meaning roughly either quantity of the thing seen or quantity of occasions on which the thing is seen.)

The constructions in (61)-(63) have several peculiarities which are worth remarking at the outset. First, they resist definite determiners:

66) Harry got to be more of $\left\{ \begin{smallmatrix} a \\ *the \end{smallmatrix} \right\}$ celebrity.

67) He's enough of $\left\{ \begin{smallmatrix} a \\ *the \end{smallmatrix} \right\}$ coward to pull the trigger.

Second, they read as predicatives:

68) ?John is more of a next-door neighbor than Pete.

69) John is more of a next-door-neighbor-type than
Pete.

(68) is odd because next-door neighbor, unlike celebrity,

coward, fool, man, bastard and such, is a rather vapid epithet; (69) makes it clear that next-door neighbor is intended as an epithet. Third, they appear in typically predicative positions:

70) What his father wants him to be is more of a man.

71) ?More of a man is here.

72) ?I've kicked more of a man than you have.

(Exclude the partitive-quantifier readings from (71), (72).)

Fourth, this predicative reading is often more accessible in negative contexts:

73) ?I've known more of a man than Frank.

74) I've never known more of a man than Frank.

It may be that the differing semantic values of elements like more and enough -- that is, whether they specify degree/extent or amount -- are a function of differing grammatical contexts: when "modifying" adjectives, adverbs, predicative NP's, or VP's, they specify degree or extent; when modifying nonpredicative NP's or occurring substantivally, they specify amount. But it is clear from the above survey that more and enough must be analyzed in a way which captures their many syntactic and semantic similarities.

(3) The Underlying Distribution of more and enough

Because we have analyzed more as er much or er many, we can now see that the underlying generalization is about

much, many, and enough. Much (like little in (4)) can select mass nouns but not indefinite plurals, while many (like few in (5)) can select indefinite plurals but not mass nouns: *many bread, *much bread, *much people, many people. Enough can select both mass nouns and indefinite plurals: enough bread, enough people. Only those Q's which select mass nouns, namely much, little, enough, can select adjectives and adverbs or function "adverbially". These are also the only Q's which can semantically signify degree or extent as well as amount.

We now see that the distribution of more is just the underlying distribution of Det-much and Det-many:

(as a substantive)

- 75) As much has happened in the last week as has happened all year.
- 76) He offers so much that we feel he is overqualified.
- 77) He was hoping for too much.

(as an adverb)

- 78) Sally eats caviar too much for her own good.

(as either of the above)

- 79) John eats so much.

(as a partitive)

- 80) He gave me as many of his marbles as I'd asked for.
- 81) He gave me many marbles.
- 82) I have much of the manuscript left to type.
- 83) I have much typing to do.

(as an adverbial modifier of adjectives and adverbs)

84) *He looks so much formidable → He looks so formidable.

85) *She speaks too much clearly → She speaks too clearly.

(as a predicative modifier)

86) I'm as much of a man as you are, my dear.

87) Harry got to be as much of $\left\{ \begin{array}{l} a \\ *the \end{array} \right\}$ celebrity as his father.

88) ?As much of a man is here.

89) ?I've seen as much of a coward as Frank.

90) I've never seen as much of a coward as Frank.

Note that many can take the place of an NP, as can the plural more:

91) Many are called; few are chosen.

92) More are called than are ever chosen.

Much and enough both may signify either amount or degree/extent, depending on the grammatical context. Much deletes before adjectives and adverbs by rule (10), following rule (20), and enough permutes around adjectives and adverbs. Actually, it is more accurate to say that enough permutes around any constituent it modifies if that constituent has no intervening determiner: [enough X → X enough], where X = A, N. Thus we have the following derivations, drawing on the discussion in section (2):

93) We made enough pudding to last for days → enough-permutation
We made pudding enough to last for days.

94) *We ate enough a pudding to satisfy us + rule (54)

We ate enough of a pudding to satisfy us.

95) We ate enough puddings to last for days + enough-
permutation

We ate puddings enough to last for days.

96) We ate enough the puddings to satisfy us. + rule (54)

We ate enough of the puddings to satisfy us.

The permutation of enough is optional with nouns, obligatory otherwise, but in both cases contingent on the absence of an intervening determiner.

Considering first the predicative NP's discussed above, we observe that they occur not only with more, much, and enough, but also with kind, a bit, sort, something:

97) John is the $\left\{ \begin{array}{l} \text{kind} \\ \text{sort} \end{array} \right\}$ of $\left\{ \begin{array}{l} \text{a} \\ * \text{the} \end{array} \right\}$ fool that I told you about.

98) He's $\left\{ \begin{array}{l} \text{a bit} \\ \text{something} \end{array} \right\}$ of $\left\{ \begin{array}{l} \text{a} \\ * \text{the} \end{array} \right\}$ gossip.

Now certain of these expressions, e.g. kind, sort, occasionally permit the omission of the a(n), as in (99), (100):

99) John is the $\left\{ \begin{array}{l} \text{kind} \\ \text{sort} \end{array} \right\}$ of fool that I told you about.

100) What is he, some kind of bird-watcher?

Note that of remains in (99) and (100); but we do not have a corresponding expression *enough of fool. However, we do have

101) He's fool enough to try it.

which presumably comes from enough (of) a fool by omission of a(n) and of. (If of were deleted rather than inserted, as suggested in n.9, the derivation of (101) would be simpler.) Note that the a(n) missing in (101) must normally

be present:

102) *He's fool.

And as expected, enough cannot permute when a(n) remains:

103) *He's a fool enough to try it.

(Exclude the irrelevant post-object adverbial reading from (103).)

It is quite striking that enough behaves the same way with adjectives and adverbs:

104) *She's (just) enough tall →

She's (just) tall enough.

105) *She speaks enough clearly →

She speaks clearly enough.

But when a Det intervenes between adjective or adverb and enough, permutation is blocked:

106) She's (just) enough too tall to be disqualified ✗

*She's (just) too tall enough to be disqualified.

The enough permutation rule applies to both the partitive and "adverbial" enough. (Observe that the just in (104) is associated with enough, not tall, and is similar in meaning to just enough in just enough time: this is further evidence that enough permutation does take place.)

The fact that the "quantifier" enough can modify adjectives and adverbs should make it more plausible that another "quantifier", much, does so.

One difference between enough and much is that enough

prohibits Det elements:

107) * { so
as
too
that } enough

*enough_{er}

Let us say that while enough is a Q like much, it is sub-categorized for a null Det:

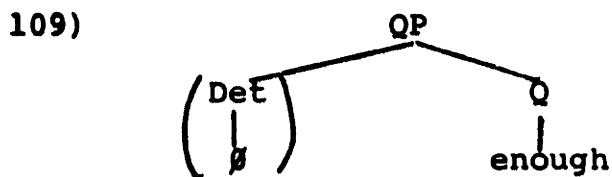
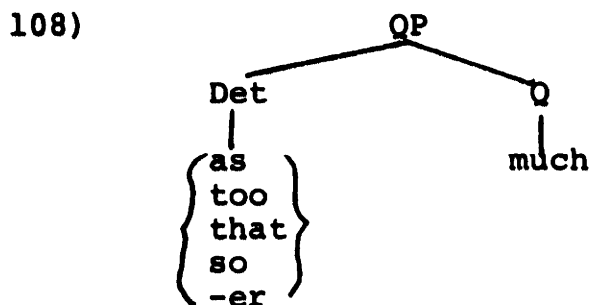

The hypothesis embodied in (108), (109) has some interesting confirmation. Observe that the output of -er-encliticizing (rule 20) is structurally identical to (109):

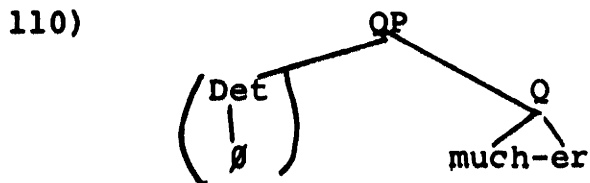

In other words, at some point in derivations enough and more are structurally distinguishable from as much, too much, etc. Now there appears to be a transformation whose structural description is satisfied by more (less) and enough and not by as much, etc. We see the effects of this

transformation in the following paradigm:¹⁰

- 111) a. He's that reliable a man.
 b. *He's a that reliable man.
- 112) a. He's too reliable a man.
 b. *He's a too reliable man.
- 113) a. He's as reliable a man.
 b. *He's an as reliable man.
- 114) a. He's so reliable a man.
 b. *He's a so reliable man.
- 115) a. ?He's more reliable a man
 b. He's a more reliable man.
- 116) a. ?He's reliable enough a man.
 b. He's a reliable enough man.

The (b) sentences of paradigm (111)-(116) are impossible for all but more and enough. (Less behaves exactly like more in this respect, as we would expect.) From (108), (109), rule (20), and (110), we may guess that it is the empty Det that causes more and enough to distinguish themselves in this paradigm.

There is good evidence that this guess is correct. In the case of the -er morpheme there are elements which appear to co-occupy the determiner node, namely, any and no. Consider

- 117) Tom was not more reliable than a grasshopper.
 118) Tom wasn't any more reliable than a grasshopper.

119) Tom was no more reliable than a grasshopper.

No, but not not, appears to be part of the adjective phrase:

120) *Not more reliable a man could be found.

121) No more reliable a man could be found.

In subject position, no adheres to the AP; it must be associated with the Det of the AP rather than the NP because of *no a man. (The impossibility of (122))

122) *Any more reliable a man could not be found.

merely reflects a general prohibition against negative-dependent elements occurring to the left of the negative under certain conditions:

123) I don't want {trouble
 {any trouble}}

124) {Trouble
 {*Any trouble}} is what I don't want.)

Assuming, then, that any and no can co-occupy the Determiner with -er, our preliminary guess correctly predicts the following facts:

125) a. ?John is not more reliable a fellow than Bill.

b. John is not a more reliable fellow than Bill.

126) a. John isn't any more reliable a fellow than Bill.

b. *John isn't an any more reliable fellow than
Bill.

127) a. John is no more reliable a fellow than Bill.

b. *John is a no more reliable fellow than Bill.

The addition of any and no to the Det causes more reliable to behave like as reliable, too reliable, etc., in paradigm (111)-(116); this confirms the guess that (115) and

(116) are distinguished because of their empty Determiners. (Parallel examples with enough may also be found: just tall enough a woman vs. *a just tall enough woman.)

I will return to a more detailed discussion of the AP shifting phenomenon in sections (5) and (6). Its introduction here has served to establish that more and enough are determiner-less Q's at some stage in the derivation.

(4) The Relation between QP and AP

The preceding sections show that comparative words such as more are instances of "QP" -- a quantifier-like structure dominating such "Q's" as much, many, little, few, enough. QP modifies adjectives and adverbs as well as nouns, so that we have a uniform treatment of more, enough, etc., whatever their syntactic context or semantic function. I now examine the structure of "QP" and its relation to AP.

The members of QP modify not only nouns, adjectives, and adverbs, but other QP's: too many more, much too much, as much too much (as before). From examples like (128), which may be extended at will, it is clear that there is recursion in QP:

128) many too many too many

Some have proposed that this recursion goes through the Det (e.g., Selkirk 1970, Bowers 1970):

129)

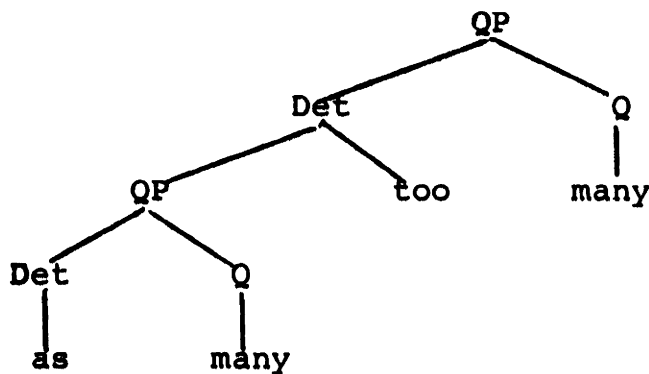

But (129) implies that as many too is an immediate constituent of as many too many, i.e., that the proper bracketing is (130a) rather than the more intuitive (130b):

- 130) a. [[[as many] too] many] marbles
 b. [[as many][too many]] marbles

The correct constituent structure is more closely represented by (131) than by (129); the \overline{QP} allows a left-nested structure while keeping QP intact as a constituent:

131)

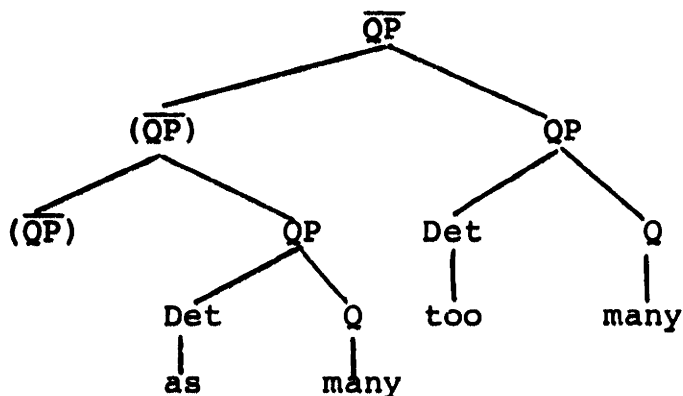

This is shown by the fact that the inner Det Q behaves like a single constituent under a certain movement rule:

- 132) a. I have as many too many marbles as you +
 b. I have as many marbles too many as you.
 133) a. I have 6 too many marbles +
 b. I have 6 marbles too many.

This rule, which I will call "QP-shift", sends $QP_1 QP_2 NP \rightarrow QP_1 NP QP_2$. From it we see that (134) is preferable to (135):

134)

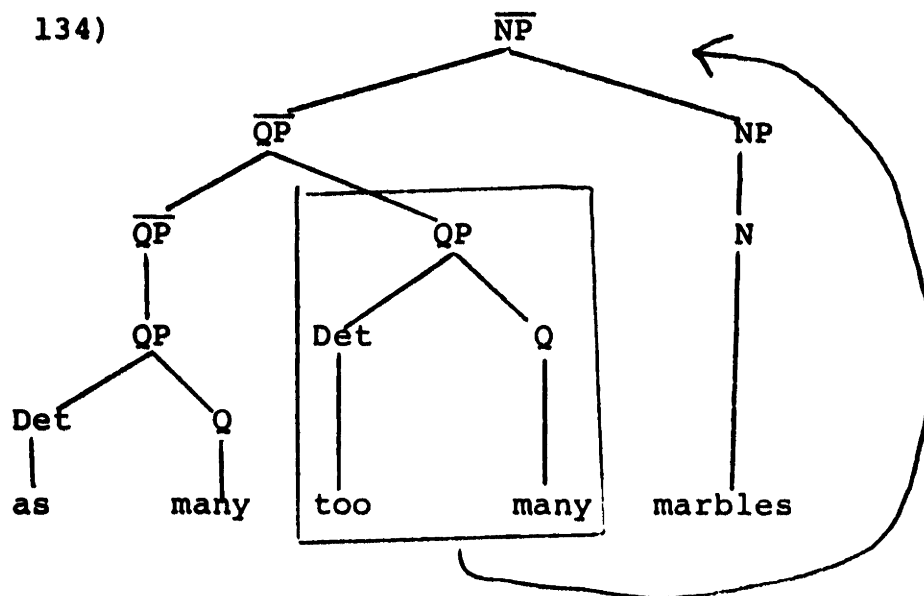

135)

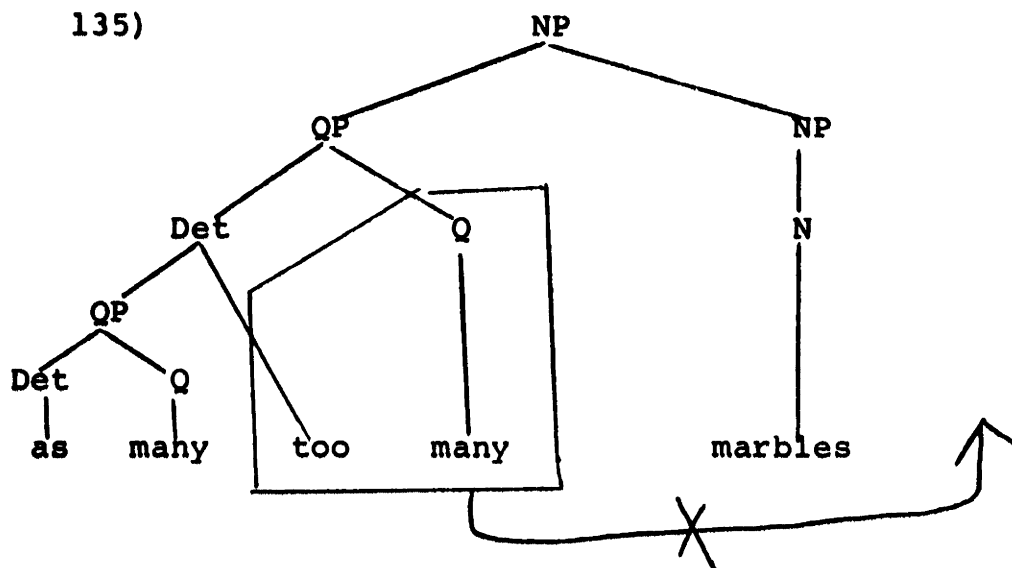

(To save (135) one might propose that NP moves into its own Det between two AP's, but this would entail that as many marbles too is an immediate constituent of the object in (132b) and would make a far-fetched type of rule.)

QP-shift must follow of-insertion (or deletion) to account for

136) a. I have 6 more of them.

b. *I have 6 of them more.

137) a. I have half a dozen too many of these marbles.

b. *I have half a dozen of these marbles too many.

Note also that only the "count" Q's can undergo QP-shift:

138) a. much too much bread

b. *much bread too much

139) a. many too many marbles

b. many marbles too many

The internal structure of "QP", then, can be given by the rules

140) a. $\overline{QP} \rightarrow (\overline{QP}) QP$

b. $QP \rightarrow (\text{Det}) Q$

\overline{QP} modifies adjectives and adverbs in cases like as much too tall, too much happier. Let us now turn to the structure of these AP phrases.

First, I will utilize the idea that most adverbs are just adjectives which happen to be immediately dominated by AP or VP. (This idea is due to Emonds 1970). The difference between sufficient rope and sufficiently long -- that one is an NP and the other an AP -- would determine the form that the A sufficient(ly) took. Then we can assign the same structure to really clever and really cleverly:

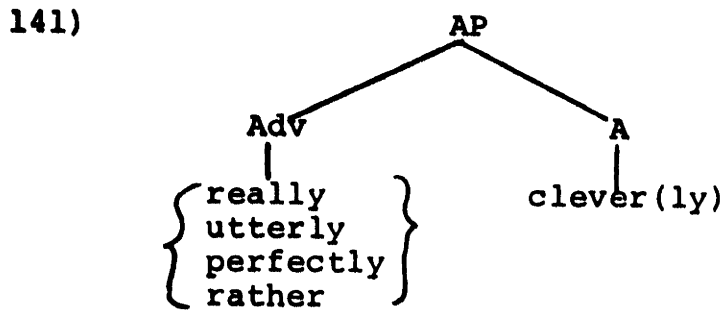

The class of elements occupying Adv in (141) is not related to attributive adjectives, but seems to be a set of special intensive words. For example, we have Mary is clever, Mary acted cleverly, but not *Mary is utter, *Mary acted utterly. The attributive perfect and real are quite distinct semantically and syntactically from the Adv perfectly and really, which have little to do with perfection or reality.¹¹

Now observe that the AP is left-nesting, like QP:

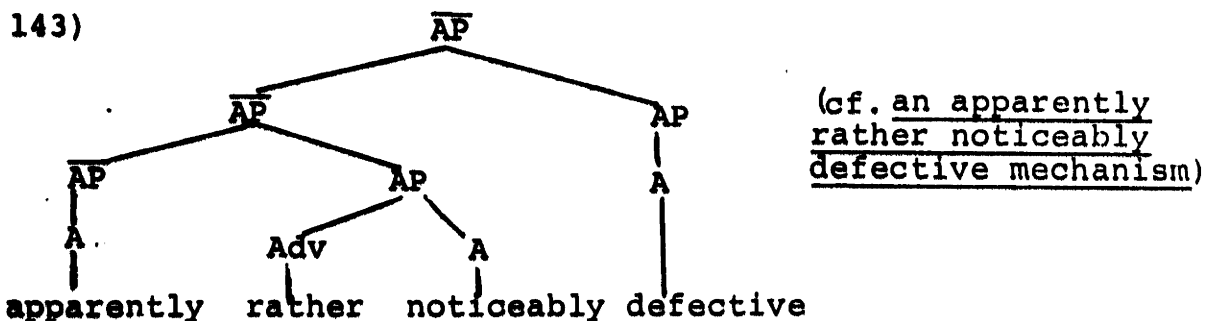
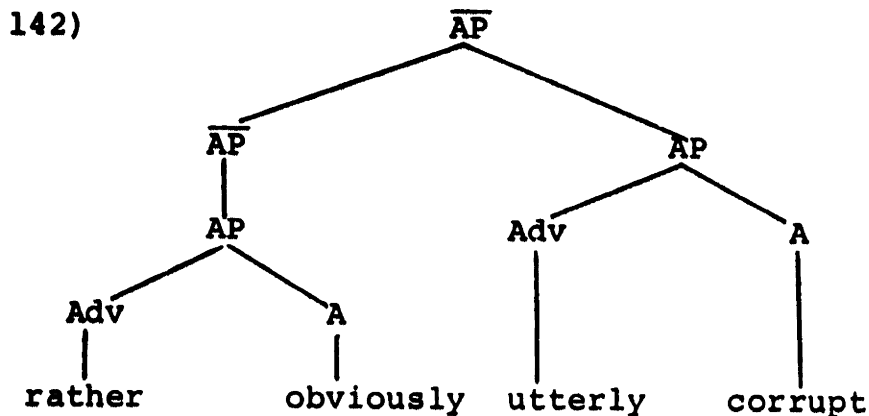

Thus the AP rules are like the QP rules (140):

- 144) a. $\overline{AP} \rightarrow (\overline{AP}) AP$
 b. $AP \rightarrow (Adv) A$

In section (1) we already observed that AP modifies AP: more corrupt, defective enough (to warrant replacement).

But now we observe that AP also modifies QP: rather noticeably more, quite obviously too much. Not only do QP and AP appear to have the same internal structure ((140) and (144)), they appear to be interchangeable. (I am speaking, of course, of the "mass" QP's like much; the "count" QP's like many share certain properties of NP's, such as of insertion (too many of them, a box of them.) One way of stating this fact would be to 'collapse' the phrase structure rules for AP and QP. We could go one step further and adopt Chomsky's base schema hypothesis (1971b), which states that the phrase structure rules for a given grammar are derivable from a set of abstract rule schemata and a decomposition of the categories into features. The category QP would share features of AP and NP. We could then write

- 145) a. $\overline{X} \rightarrow (\overline{X}) \overline{X}$
 b. $\overline{X} \rightarrow (Spec, \overline{X}) \overline{X}$

\overline{X} corresponds to \overline{AP} , \overline{QP} , and \overline{NP} : it is an "archi-category", much as /D/ is an archi-phoneme comprehending /d/ and /t/.

\overline{X} corresponds to AP, QP, and NP. \overline{X} corresponds to what

I have called A, Q, N; \bar{X} would actually include X and a complement, but I am disregarding this refinement. (Spec, \bar{X}) is a function of \bar{X} : it would yield {-er, so, too, ...} if $\bar{X} = Q$; {rather, utterly, quite, ...} if $\bar{X} = A$.

However, lacking a worked-out theory of category features, I will continue to use the perspicuous and familiar NP-AP notation; and I will continue to use "QP" as an abbreviation for a "mixed" category sharing features of NP and AP. Thus, to express the relation between QP and AP, I will write¹²

- 146) a. $\left\{ \frac{\overline{AP}}{QP} \right\} \rightarrow \left(\left\{ \frac{\overline{AP}}{QP} \right\} \right) \begin{matrix} AP \\ QP \end{matrix}$
 b. AP \rightarrow (Adv)A
 c. QP \rightarrow (Det)Q

These rules generate the structures underlying as clear, clear enough:

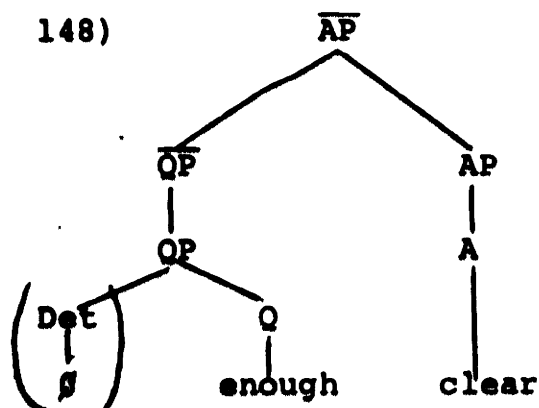
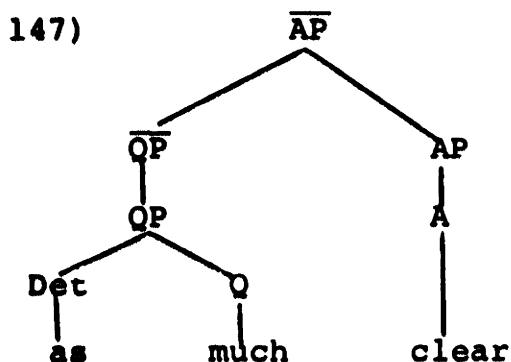

For the more complex structures underlying as utterly stupid and as obviously stupid we have

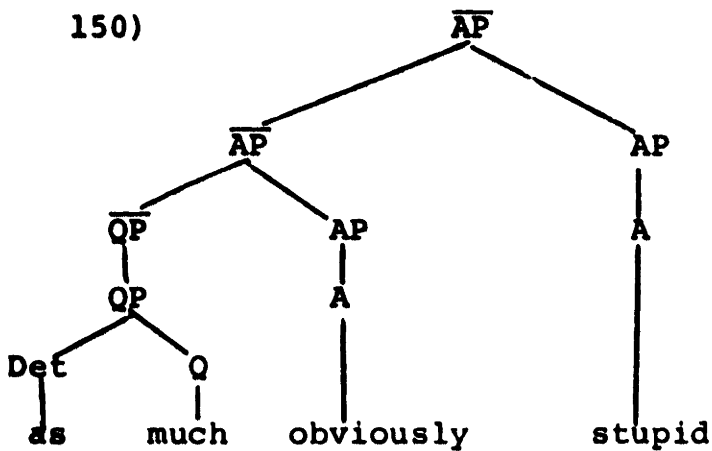
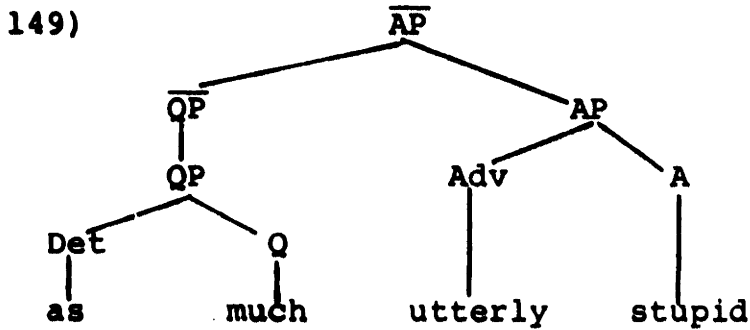

For much too obviously clever and slightly more obviously clever:

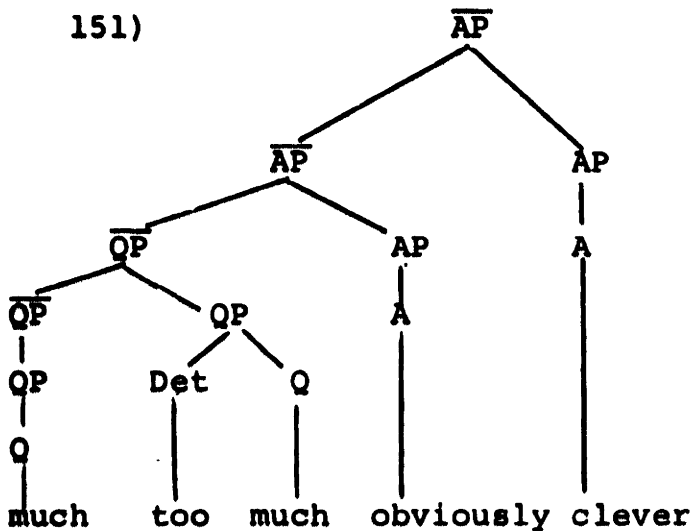

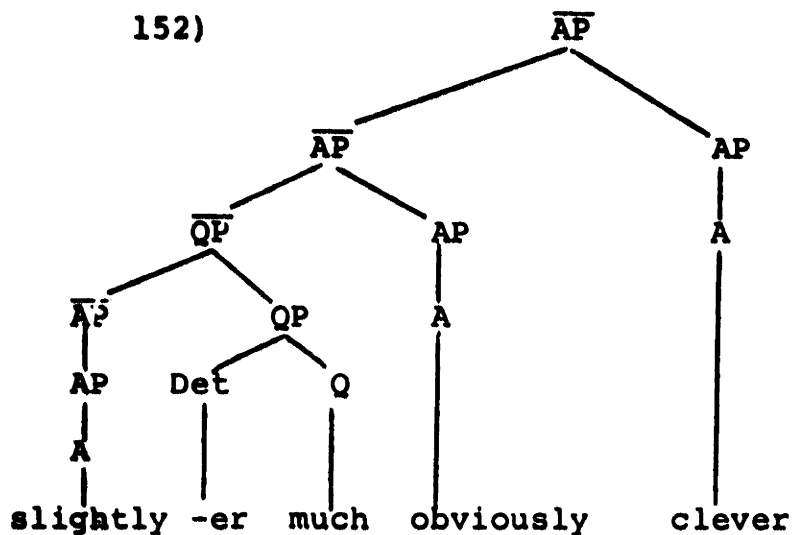

For decidedly too tall, quite considerably less intelligent,
nearly as many too many more, much too much too much too
tediously repetitive:

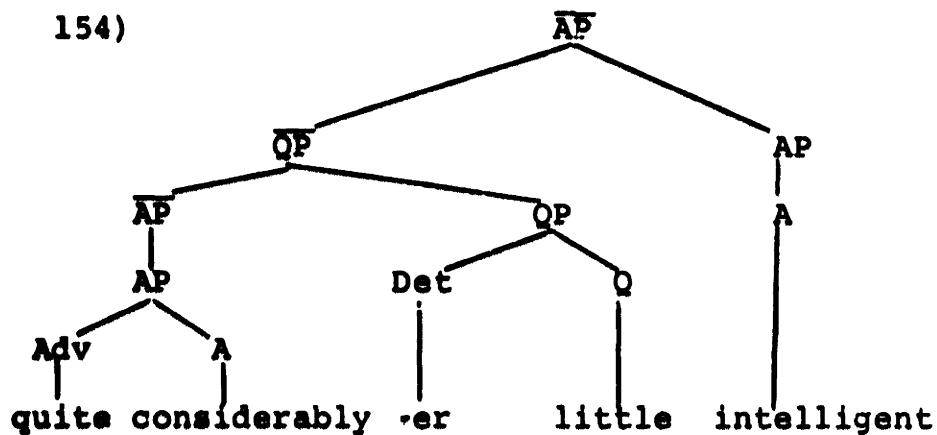
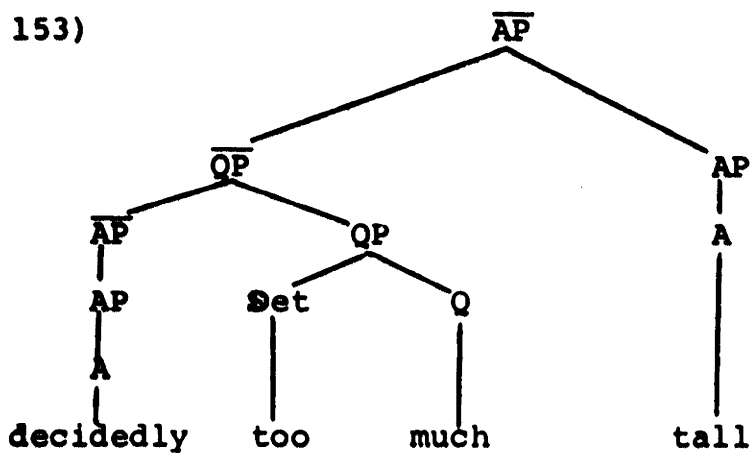

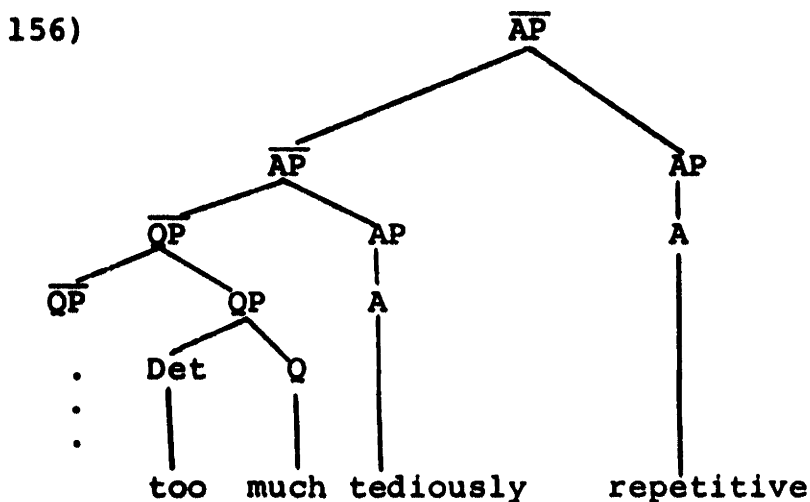
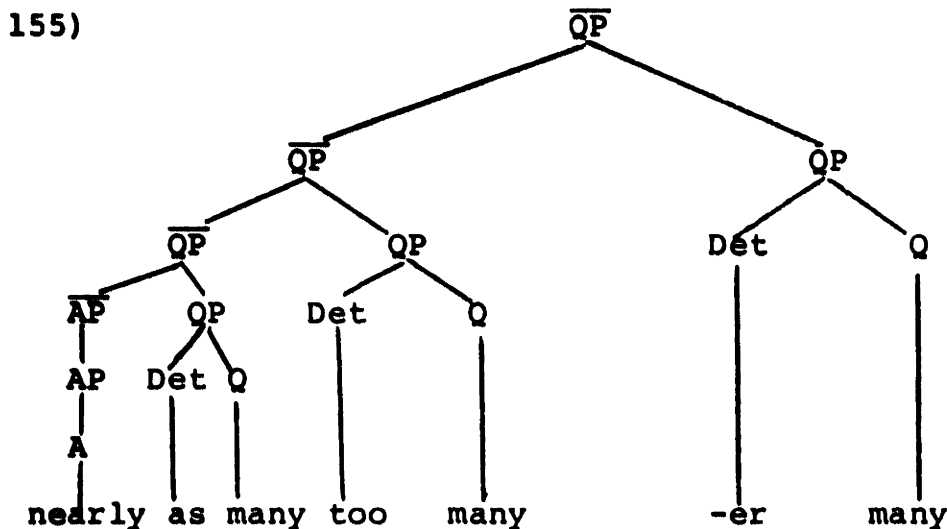

As we see, adverbial QP and AP are generally interchangeable structures. Some further confirmation appears when we re-examine the curious predicative constructions of sections (2) and (3), such as much more of a man, enough of a fool. This type of construction may be given the analysis shown in (157):

- 160) What her mother wants her to be is as strong a person as possible.
- 161) ?As brilliant a woman is here.
- 162) ?I've known as strong a person as Louise.
- 163) I've never known as strong a person as Louise.

Thus we may give a preliminary account of the AP shifting phenomenon of section (3) by deriving a taller man, a good enough student from structures similar to (158): *taller a man, ?good enough a student (see n. 10). The derived forms share the same set of special properties shown in (159)-(163):

- 164) Fido is $\left\{ \begin{array}{l} a \\ *the \end{array} \right\}$ smarter dog than Spot.
- 165) What his father wants him to be is a better pool player.
- 166) ?A taller man than Bill is here.
- 167) ?I've known a smarter dog than Fido.
- 168) I've never known a smarter dog than Fido.

These facts provide further support for our analysis.

(5) so and the Formation of such

Given the above structures, we are now in a position to extend our analysis. To see how the AP shift transformation must be formulated, it is first necessary to examine the alternation of so and such, for AP shift appears to

apply when so occupies Det:

- 169) a. He's so tall a man that doors are dangerous
to him →
- b. He's such a tall man that doors are dangerous
to him.

The phrase-type such a tall man that... shares many properties of construction (158):

- 170) He's such ^a{*the} tall man.
- 171) What her mother wants her to be is such a fine
surgeon that everyone will respect her.
- 172) ?Such a vile man was there that we left.
- 173) ?I've known such a vile man that....
- 174) I've never known such a vile man that....

In the above examples it appears that such is the residue (or pro-form representative) of the pre-article AP.

Further, it appears that such may be a derivative of so, perhaps as in (175):

- 175) so tall a man →
*so a tall man →
such a tall man

As preliminary hypothesis, we may say that

- 176) so → such / [____ NP]

The alternation of so and such is quite systematic:

as and that clauses):

184)

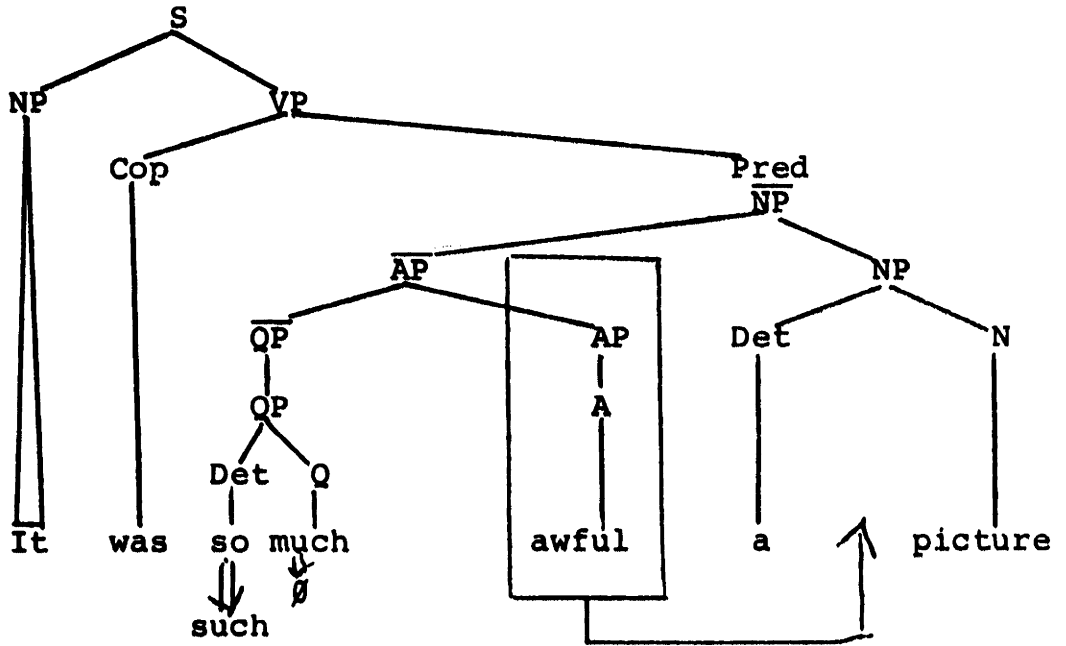

It was such an awful picture (that I tore it up)

185)

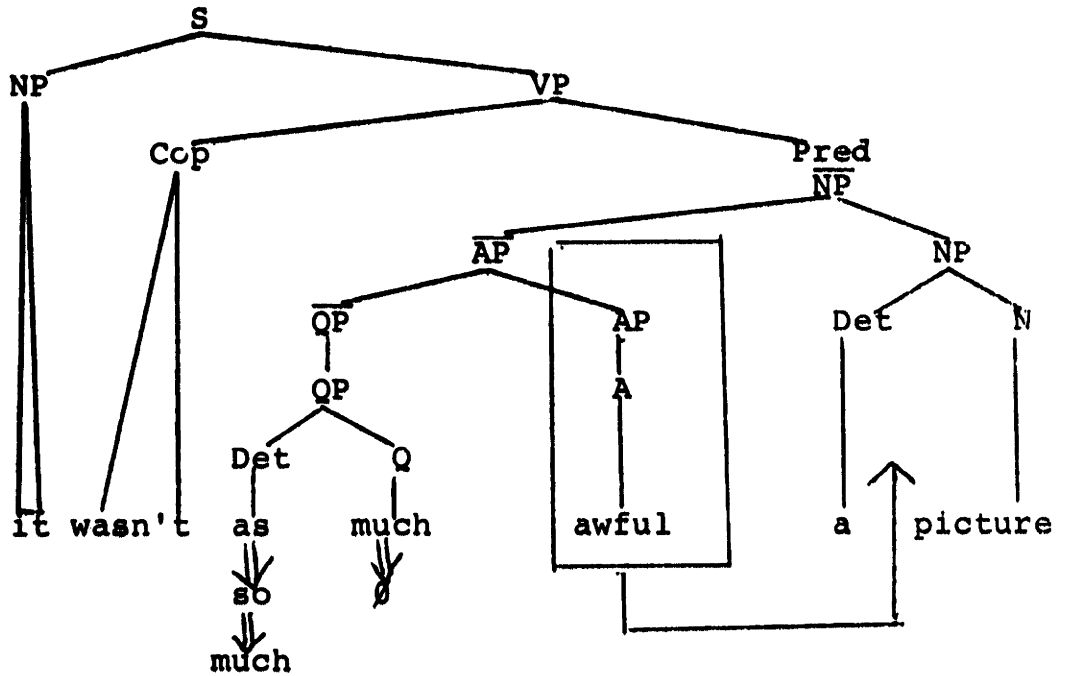

It wasn't such an awful picture (as it first seemed).

(The formulation of AP shift is discussed in section (6).)

The degree or extent readings of such in (183) and (181) come ultimately from the underlying much which is deleted before A's, as shown in (184), (185). Degree or extent readings for such also occur in cases like the following:

186) Mary is such a wit that people are afraid of her.

187) Sally isn't such a fool as people think.

Note that the such in (187) is negatively conditioned:

188) *Sally is such a fool as people think.

In (186) and (187), where a wit and a fool are predicative nouns or epithets, we may also suppose that a much has been deleted, allowing such to form from so or negatively conditioned as, since they are contiguous to the NP:¹³

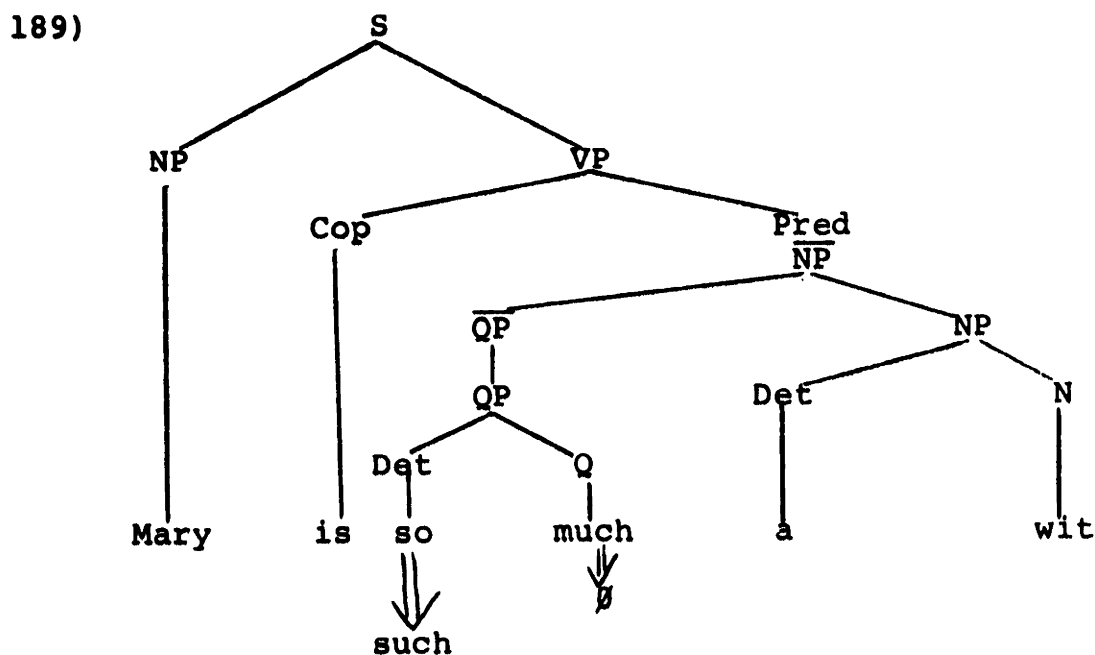

Mary is such a wit (that people are afraid of her)

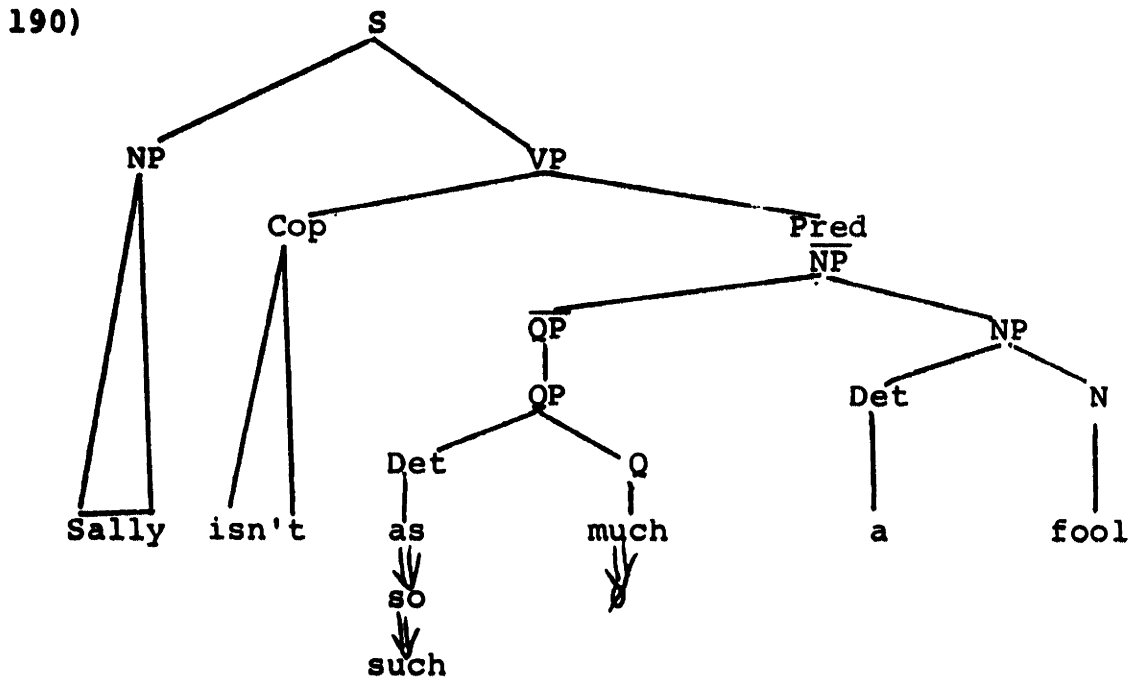

Sally isn't such a fool (as people think)

In the above cases, (184), (185), (189) and (190), such modifies either an adjective (awful) or a predicative noun (a wit, a fool) and signifies the degree or extent to which the epithet applies. In both cases, such is the surface proform for an underlying pre-NP structure -- either an AP or QP. And in both cases, such is formed from a so which -- through various transformational processes -- has come to be contiguous to an NP.

But this account of so and such is incomplete. So and such may indicate character or kind as well as degree or extent. Both readings occur in the following ambiguous sentence:

191) Hilda is such a scholar.

The two readings of (191) are indicated in (192), (193):

192) Hilda is such [so much of] a scholar (that all her work is impeccable).

193) Hilda is such [the kind of] a scholar (as you were speaking of just now).

The approximate meaning of (192) is "Hilda is a scholar to such an extent that all her work is impeccable", while that of (193) is "Hilda is the kind of scholar that you were speaking of just now".

The such in (193) is most likely a pro-form for an unspecified AP, as indicated in diagram (193):

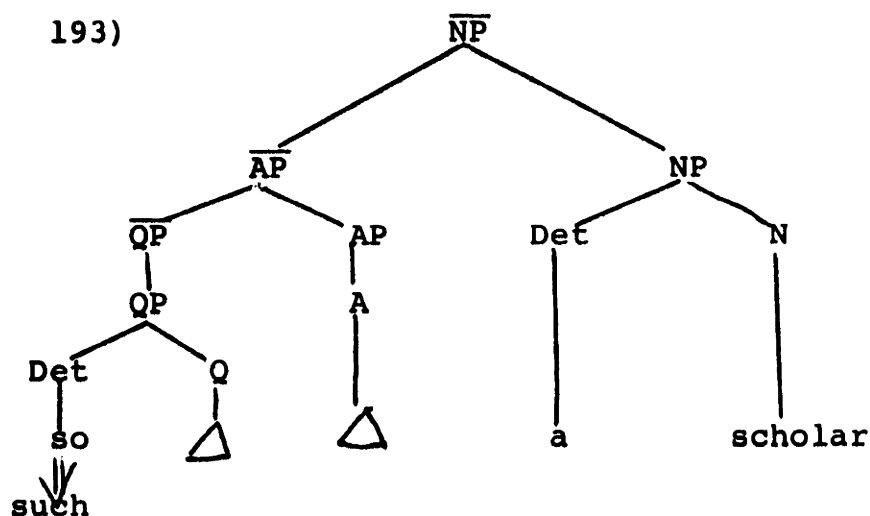

The underlying representation depicted in (193) would account for the absence of a degree/extent interpretation of such by the underlying absence of much (which is presumably a subcategorizational option for so and, in some cases, as). The adjective in (193) can, however, be specified, even when Q remains unspecified:

194) So eminent a scholar as Dr. Lucille Hein was here.

And AP shift can apply to (194), yielding (195):

195) Such an eminent scholar as Dr. Lucille Hein was here.

Thus, I am supposing so and such to be syntactically the same, despite their observed variation in meaning, which I attribute to the underlying presence or absence of much. Therefore, we should expect a subtle difference of meaning possible in the underscored components of (196), (197):

196) So elegant a solution as you have presented us with can elicit only admiration.

197) You have presented so elegant a solution that we can only admire it.

In answer to the question, "How elegant a solution was it?", we can reply " -- so elegant a solution that everyone was speechless" or "so elegant a solution that we can only admire it", but not " -- so elegant a solution as you have presented us with" or "-- so elegant a solution as yours". The reason must be that the question "how elegant...?" requests information as to degree or extent, and, as hypothesized, the such which indicates character rather than degree must come from a so subcategorized for a null Q; that so cannot be used to answer a question about degree. Perhaps the meaning of so elegant a solution in (196) and so eminent a scholar in (194) can be roughly paraphrased by "thus elegant a solution", "thus eminent a scholar".¹⁴

The absence of underlying much in (193), (194)-(196) may

also help account for another fact, although further research is required to find a complete explanation. The fact is that the non-degree occurrences of so and such also appear to be non-predicative. More explicitly, we have

198) ?Such a scholar that people are impressed is here.

?Such a scholar is here that people are impressed.

199) Such a scholar as you were speaking of just now is here.

The ill-formedness of (198), with such read as indicating degree/extent, would seem to follow from the hypothesized presence of much in (198) but not (199), for we have

200) ?So much of a scholar is here.

Altho th non-degree such and so require indefinite determiners -- *such the stuff as dreams are made of, *so eminent the scholar as Dr. Hein -- still, their general distribution is non-predicative:

201) Her mother wants Mary to be such an eminent woman that everyone will respect her.

202) ?Her mother wants Mary to be such an eminent woman as Sappho.

My aim in this section has been to present evidence that such is formed from so as the residue of a pre-NP QP or AP. This analysis permits an account of paradigms like the following:

| | |
|-------------------|------------------------------|
| 203) *such person | such trouble |
| *such the person | *such the trouble |
| such a person | *such a trouble (*a trouble) |
| such persons | such troubles |

The ungrammaticality of *such person in the face of such trouble follows from the fact that such in the former case does not precede a full NP: person is only an N, while trouble is a full NP having a null determiner. Similarly, both persons and troubles are full NP's, since the plural indefinite determiner is null. The ungrammaticality of *such the person, *such the trouble follows from the ungrammaticality of any [AP Det N], [QP Det N] sequence where Det is definite: we cannot say *such my mother, *such Fred for the same reason we cannot say *as sad my mother, *more Fred.

(6) AP-shift

From the so-such alternation, it appears that AP-shift can apply when so occupies the Determiner of Q. Let us examine an underlying structure for the particles permitting AP-shift after er-encliticizing (rule 20) has applied:

204)

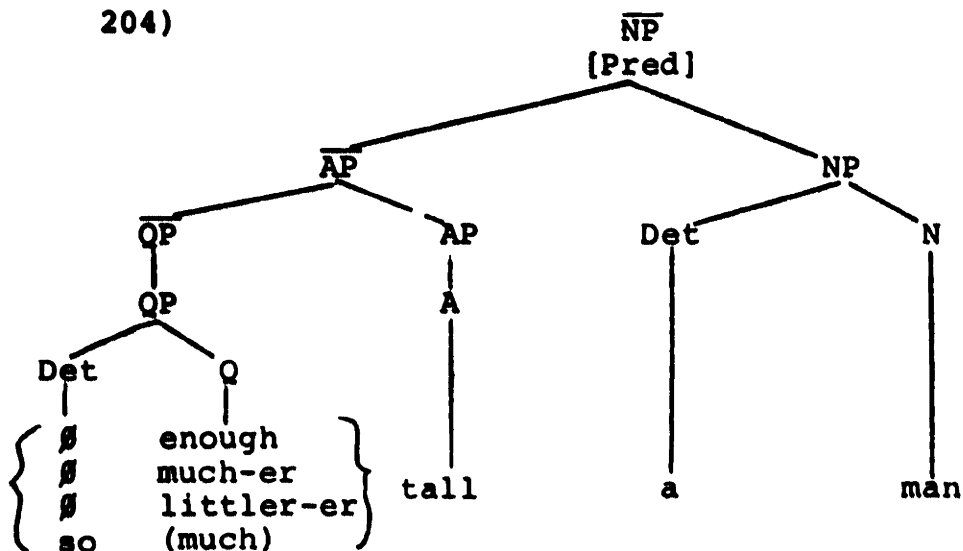

To derive a tall enough man, a taller man, a less tall man, AP-shift apparently must apply to the entire \overline{AP} of (204); yet to derive such a tall man it must apply just to the AP, so that the so will remain, becoming such. (The sequence Q AP could not be shifted, since it is not a constituent.) There are many ways of solving this problem -- one might try to shift a(n) instead of AP; one might have completely separate rules to move AP and \overline{AP} . However, I would like to sketch here an analysis which I think goes further toward providing an explanation of these and other phenomena.

This analysis factors AP-shift into two rules. Briefly, the first rule raises QP into AP just in case the Det of the Q is empty:

205)

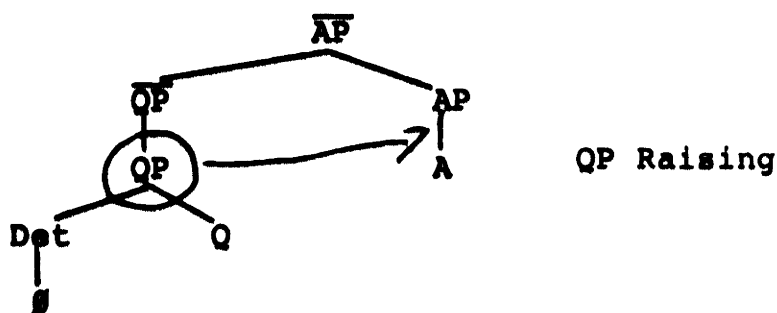

The second rule shifts AP (n.b. not \overline{AP}):

206) [NP [(so) AP] [(Det) N] NP]
 1 2 3 4 + AP shift
 1 ∅ 3 2+4

QP Raising will apply only to those QP's having empty Det's at the point of application, namely, enough, more, and less. Then AP-shift will apply. The operation of rules (205) and (206) can be illustrated as follows:

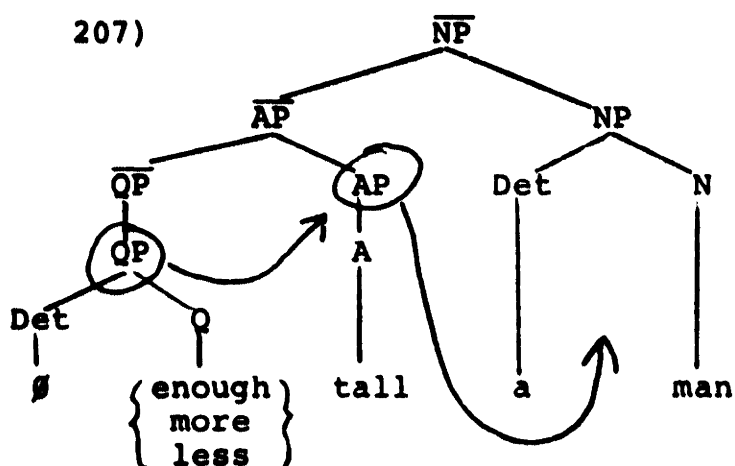

QP Raising will not apply when so, as, too, that, or any, no or other elements are in the Determiner of QP. Thus, for example, any taller a man would have structure (208) after er-encliticizing:

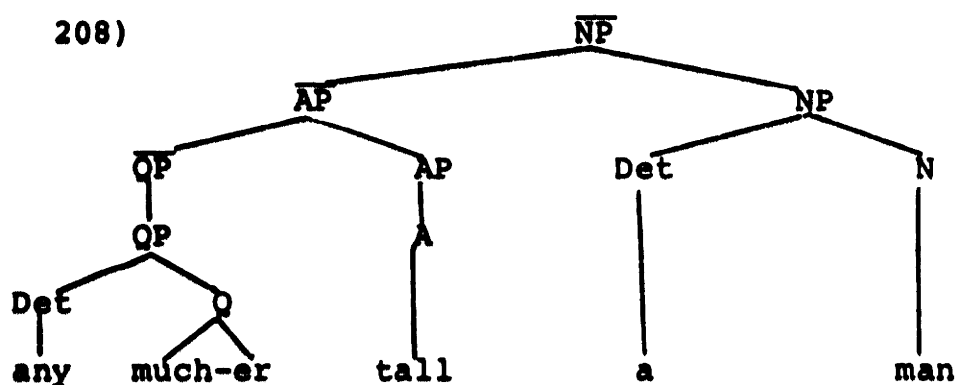

QP Raising cannot apply to (208) because of the filled Det preceding Q. Consequently, the structural description of AP-shift will not be met, since the AP is not in the environment [(so) ___ NP]; therefore, *an any taller man will not be derived. Nor does structure (209), underlying that tall a man, etc., meet the structural description of AP-shift:

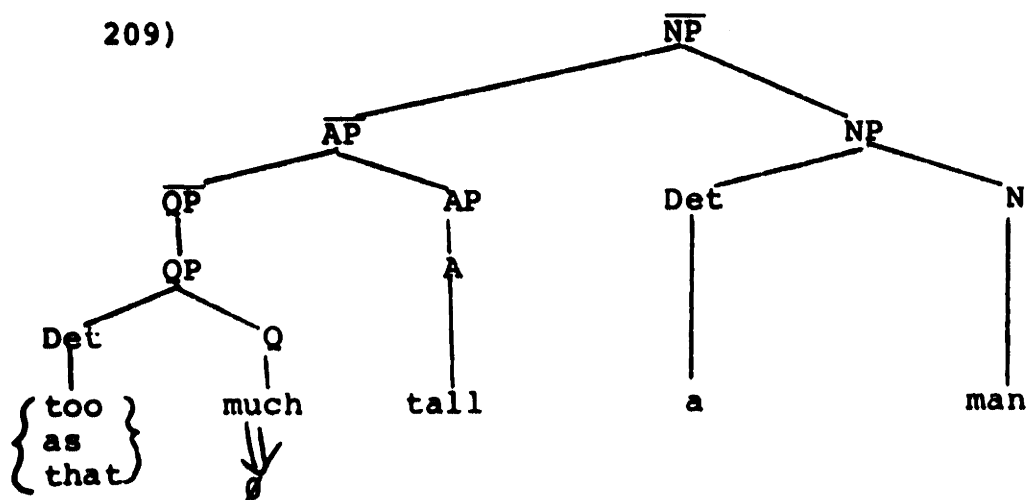

However, although QP Raising does not apply to (210), still that structure will meet the conditions of AP-shift:

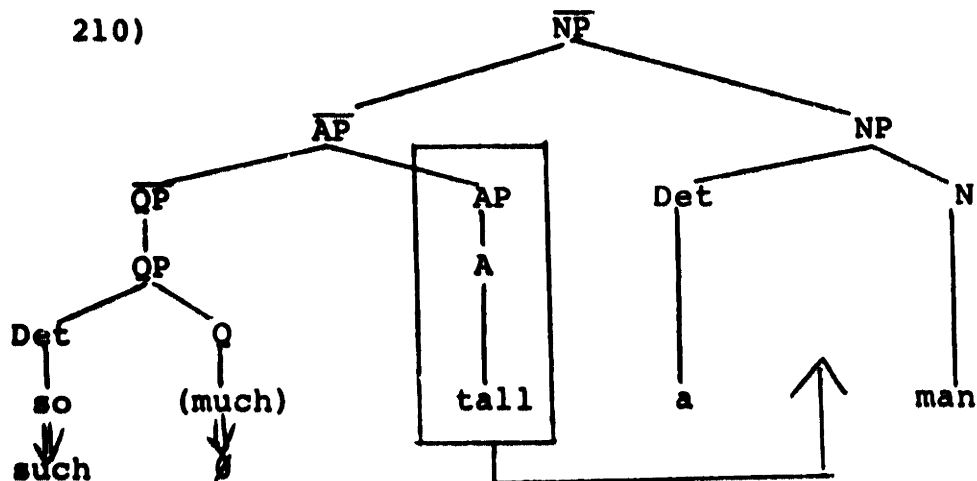

(For the degree reading of such, an underlying much is deleted; for the "kind" reading of such, Q is empty in deep structure.)

Note that AP-shift appears to be obligatory when the rightmost NP has an empty Det, as in mass nouns or indefinite plurals:¹⁵

211) *so fine food + such fine food

*so tall men + such tall men

Observe now that the QP Raising transformation appears to apply to QP and AP indifferently, with the proviso that there must be "room" for the QP (i.e., it won't raise if the higher node has a filled Det). This extension of QP Raising would explain the following facts:

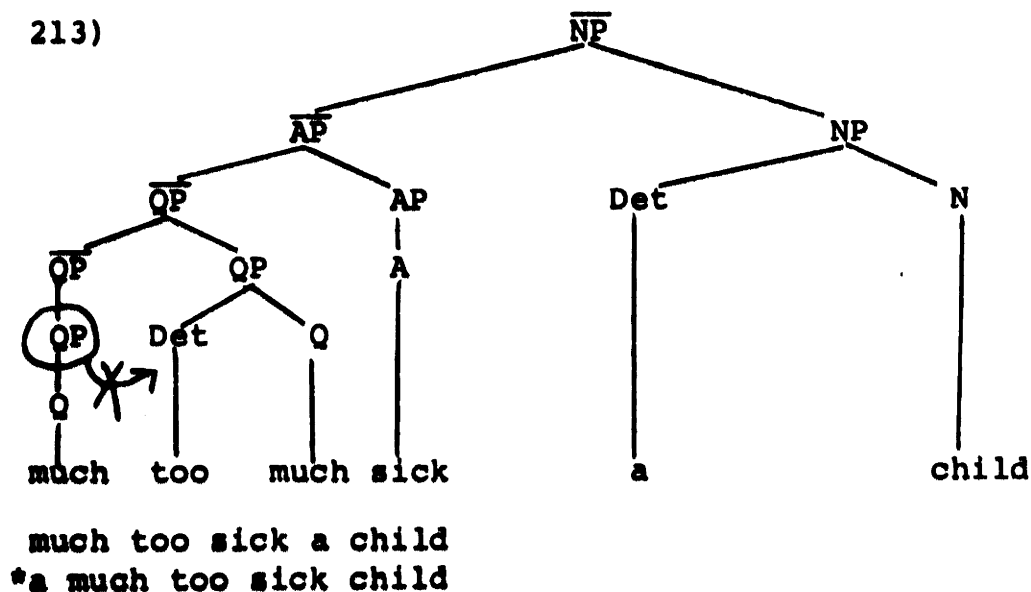
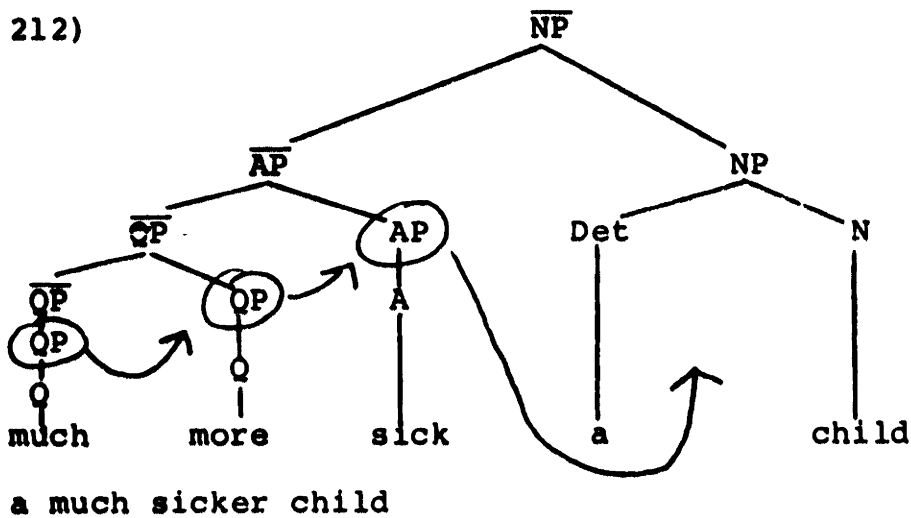

Comparing (212) with (213), we see that QP Raising will not raise much to too much because of the intervening determiner too. Thus, at no later point in the derivation will the structural description of QP Raising or AP-shift be satisfiable, as the reader may easily check.

I observed above that QP Raising applies indifferently to QP and AP. In (212) we saw that QP could raise into QP; AP can also raise into AP. For example, to obtain

214) a more obviously correct solution,

we have

215)

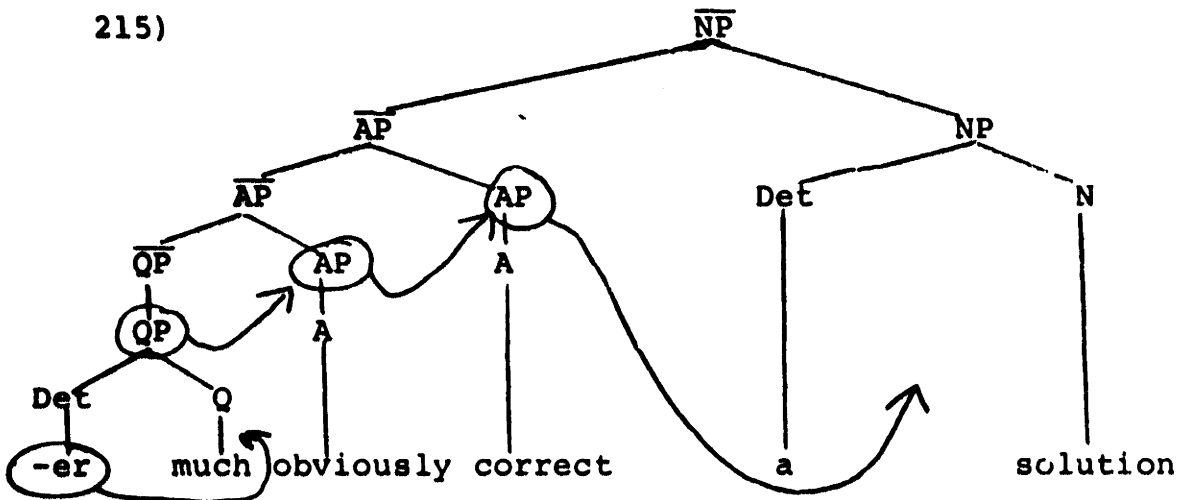

We cannot derive examples like *a much too obviously defective mechanism, however, for the same reason that prevented (213).

The fact that both QP and AP can be raised by QP Raising also allows us to derive (216b):

- 216) a. so obviously correct a solution +
 b. such an obviously correct solution

We can also explain such contrasts as (217), (218):

217) a. a decidedly taller man

b. *a decidedly too tall man

218) a. an obviously better solution

b. *an obviously $\left\{ \begin{smallmatrix} \text{so} \\ \text{as} \end{smallmatrix} \right\}$ good solution

er-encliticizing in (217a) and (218a) creates the environment for QP Raising, while the presence of non-encliticizing particles like too, so, as prevents raising and hence, ultimately, AP-shift in (217b) and (218b).

On the present analysis the empty Det is a precondition for QP Raising, while AP-shift depends in part upon there being no Q in front of the shifting AP. Thus the new account makes the direct prediction that where much is not deletable or omittable after so, AP-shift should not apply; and this prediction is borne out by the following facts.

Consider the underlying source for the underscored constituent in (219), namely (220).

219) She made so much better a reply.

220)

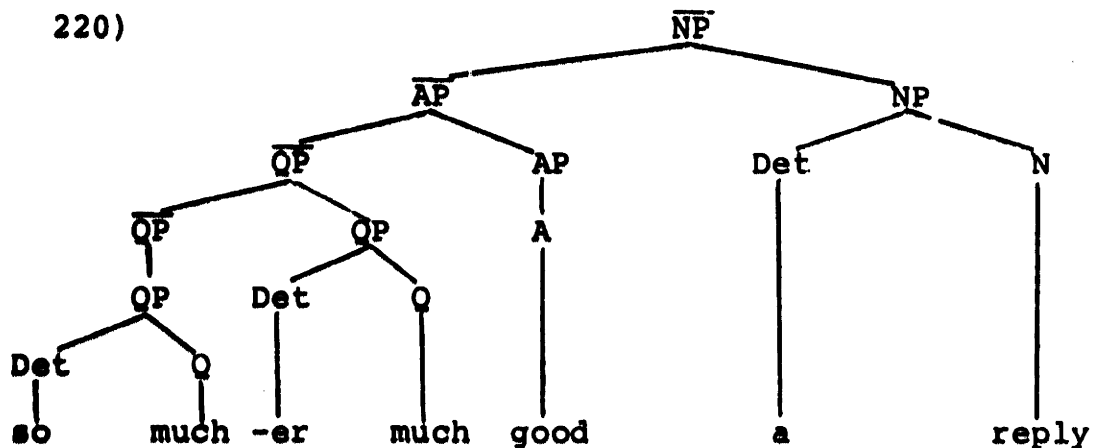

Observe that much is not deletable before Det Q: we have so much more, but *so more, *such more. Thus the environment for the various raising and shifting transformations will not be met, and the ungrammaticality of (221), (222) is correctly predicted:

221) *She made such a much better reply.

222) *She made such a better reply.

In conclusion, QP Raising and AP-shift appear to explain a variety of facts hitherto unaccounted for.

(7) A Note on Indefinite Superlatives

Suppose we discovered another determiner which could encliticize upon Q. The analysis I have given makes a number of predictions about such a determiner. Let us call the hypothetical determiner -x; then we would have -x Q + Q + x.

First, we would predict the impossibility of *as much + x, *too much + x, *so much + x, etc., for the same reason that we do not have *as more [= as much + er], *too more, etc.

Next, we would expect much + x to remain undeleted before adjectives and adverbs. That is, just as more [= much + er] friendly, like more bread remains while *too much friendly, unlike too much bread, reduces to too friendly, so much + x friendly should exist along side of much + x bread.

Finally, the empty Det preceding Q would permit QP Raising

and AP-shift to apply, and just as we have *more friendly an answer → a more friendly answer we would predict *much + x friendly an answer → a much + x friendly answer.

There does exist another Q-encliticizing determiner, and it behaves just as predicted. The determiner is -est:

| | | |
|------|-------------------|----------------------|
| 223) | much + er = more | little + er = less |
| | much + est = most | little + est = least |
| | many + er = more | few + er = fewer |
| | many + est = most | few + est = fewest |

| | | |
|------|------------------------------------|------------------------------------|
| 224) | * { as too so that } more | * { as too so that } most |
|------|------------------------------------|------------------------------------|

| | | |
|------|---------------|---------------|
| 225) | more friendly | most friendly |
| | more bread | most bread |

226) ?more friendly an answer → a more friendly answer
 ?most friendly an answer → a most friendly answer

The indefinite superlative -est must be distinguished from the definite superlative -est, which always cooccurs with the and may take a complement (either a PP or a that-complement):

227) a. a most kind answer
 b. *the most kind answer
 c. *a most kind answer that I ever heard
 d. *a kindest answer
 e. the kindest answer
 f. the kindest answer that I ever heard

a, b, and c are indefinite superlatives; d, e, and f are definite superlatives. (The difference between (217a) and (217d) was brought to my attention by Larry Horn.)

(8) Sample Analyses

I will give some examples of cases in which the transformations I have discussed (and others) map distinct underlying structures onto surface forms which have sometimes puzzled grammarians.

As a first example, consider the following paradigm.

- 228) a. I've never seen a man taller than my father (is).
 b. I've never seen a taller man than my father (is).
 c. I've never seen a man taller than my mother (is).
 d. #I've never seen a taller man than my mother (is).

(228a and c) derive from reduced relative clauses, (229) and (230), respectively:

- 229) I've never seen a man (who is) taller than my father (is).
 230) I've never seen a man (who is) taller than my mother (is).

The comparatives in (229), (230) come from a compared AP, as in (231) and (232), respectively:

- 231) [-er much tall] [than my father is [so much tall]]
 232) [-er much tall] [than my mother is [so much tall]]

That (228a and c) do indeed come from reduced relatives is suggested by the fact that they may occur with a definite determiner: supposing there is one man in town whose height exceeds my father's, I may say

233) I've never seen the man (who is) taller than my father.

234) I've never seen the one man taller than my father.

By contrast, (228b and d) cannot have definite determiners under any circumstances:

235) *I've never seen the taller man than my father.

236) *I've never seen the one taller man than my father.

This is characteristic of pre-NP AP's (*so tall the man), and we derive the comparatives in (228b and d) from (237), (238), respectively:

237) [-er much tall a man] [than my father is [so much tall a man]]

238) [-er much tall a man] [than my mother is [so much tall a man]]

As we see by examining (232) and (238), in the former case what is compared is a predicative AP -- so tall -- while in the latter case what is compared is a predicative NP -- so tall a man; that is why (228d) implies anomalously that my mother is a man.

The same analysis also explains the difference between (239) and (240):

239) John wants to come up with as good a solution as
 { Christine did. }
 { Christine's. }

240) John wants to come up with a solution as good as
 { *Christine did. }
 { Christine's. }

The compared AP in (240) cannot function as a direct object, while the compared NP in 239) can. The facts are identical with -er instead of as:

241) John wants to find a better solution than
 { Christine did. }
 { Christine's. }

242) John wants to find a solution better than
 { *Christine did. }
 { Christine's. }

Another problem resolved by this analysis is the ambiguity of more helpful advice, most helpful advice:

243) a. Most helpful advice is unwanted.

b. You've given me most helpful advice.

244) a. Sally will give me more helpful advice than destructive criticism.

b. Sally will give me more helpful advice than the advice I got from you.

These parallel ambiguities arise from two underlying structures:

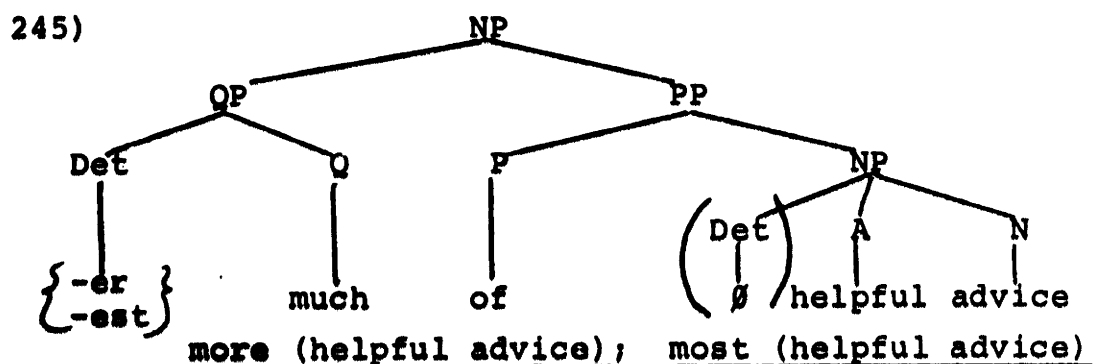

| | |
|--------------------|------------------|
| 177) so tall a man | *such tall a man |
| *so a tall man | such a tall man |
| *so tall men | such tall men |
| *so a man | such a man |
| *so men | such men |
| so tall | *such tall |
| so much | *such much |

Note further that every occurrence of such in (177) directly precedes an NP, e.g. such [a tall man NP], such [tall men NP], such [men NP]. This is just what would be predicted by rule (176) if we could motivate an underlying so in all these cases.

There is even stronger evidence for treating such as a formation of so. Notice first that as optionally alternates with so in negative environments:

178) It was $\left\{ \begin{array}{l} \text{as} \\ *so \end{array} \right\}$ awful a picture as it first seemed.

179) It wasn't $\left\{ \begin{array}{l} \text{as} \\ so \end{array} \right\}$ awful a picture as it first seemed.

In just these negatively conditioned environments, such can appear:

180) *It was such an awful picture as it first seemed.

181) It wasn't such an awful picture as it first seemed.

Thus, both the so coming from negatively conditioned as and the indigenous so alternate with such: compare (180) and (181) with (182) and (183):

182) It was so awful a picture that I tore it up.

183) It was such an awful picture that I tore it up.

The formation of such in cases like (183), (181) can be summarized in the following two diagrams (omitting the

246)

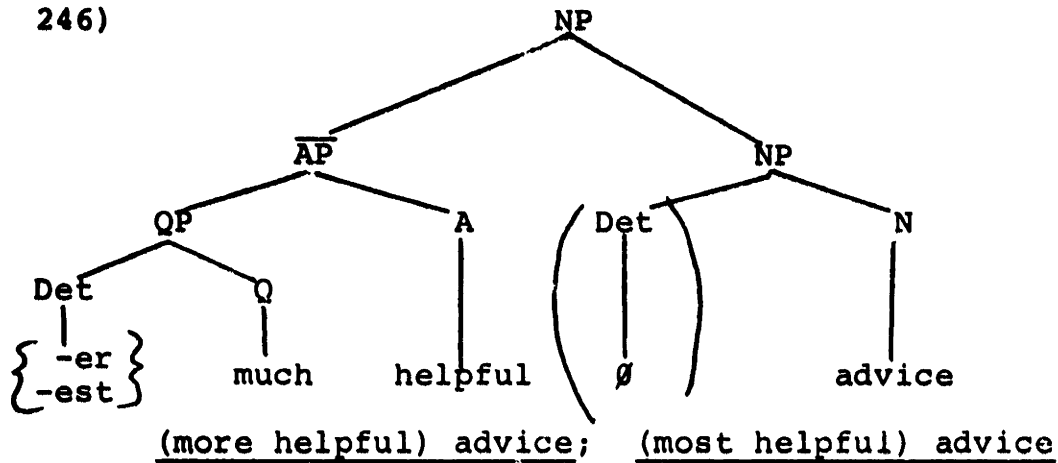

The underscored components of (243a), (244a) derive from the "amount" quantified structure (245), while those of (243b), (244b) derive from the "degree" structure in (246). Notice that one can pronominalize in the (a) cases of (243), (244) -- Most of it is unwanted; she'll give you more of it. The presence of pronouns prevents of-deletion and reveals the underlying structure more clearly.

A similar syntactic ambiguity occurs in (247), which was pointed out to me by David Vetter:

247) I've never seen more intelligent dogs.

a. = more (intelligent dogs)

b. = (more intelligent) dogs

The (a) reading comes from (248) and the (b) reading from (249):

248)

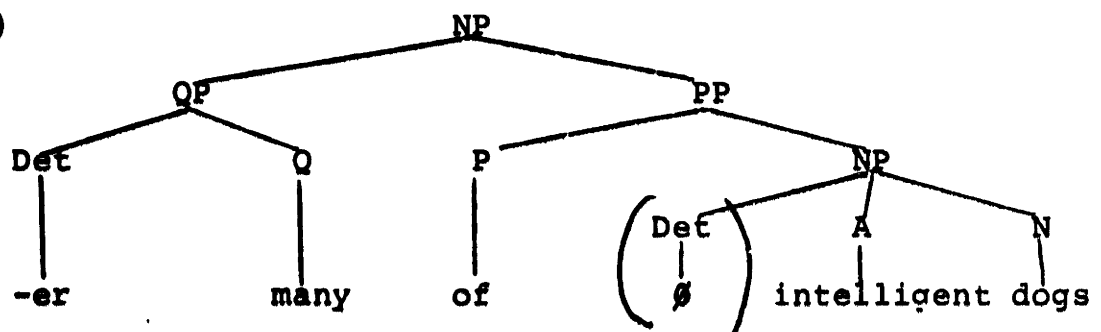

249)

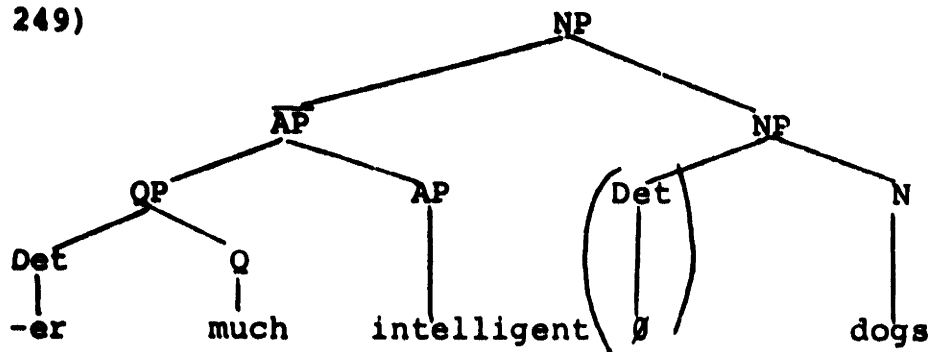

For (250)

250) much more intelligent dogs

There is only one analysis, since much cannot modify plurals: much too much, *much too many, *much dogs. Therefore the presence of much in (250) "forces" the much interpretation of more, and the analysis must be that shown in (251):

251)

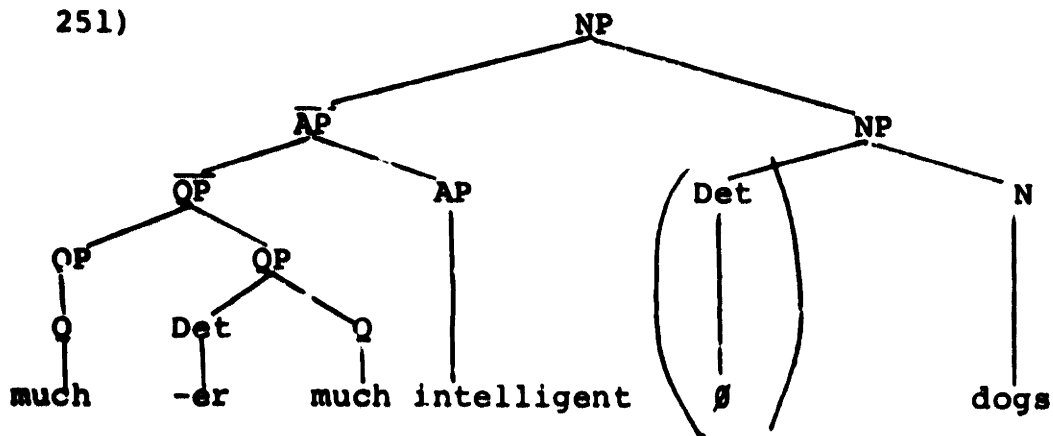

On the other hand, (252) is still ambiguous:

252) many more intelligent dogs

a. = many (more intelligent) dogs

b. = (many more) (intelligent dogs)

(a) comes from (253) and (b) from (254):

253)

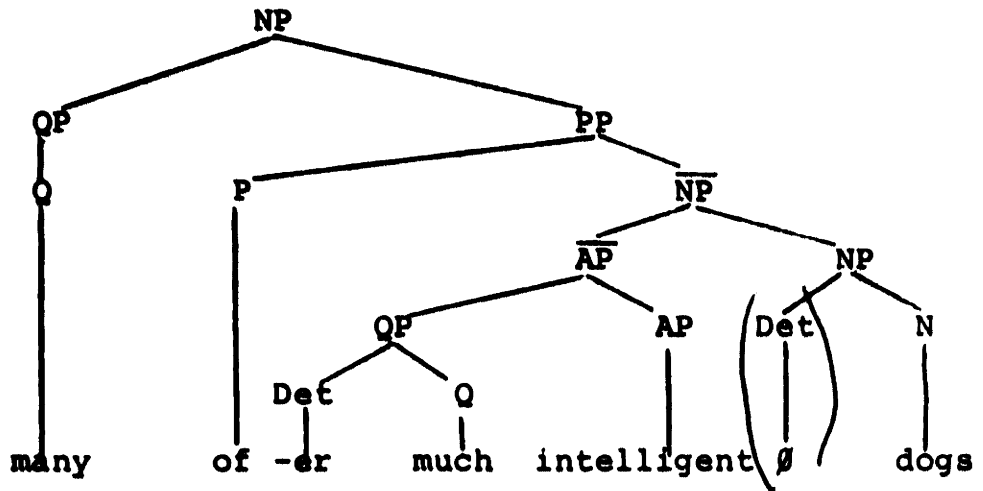

254)

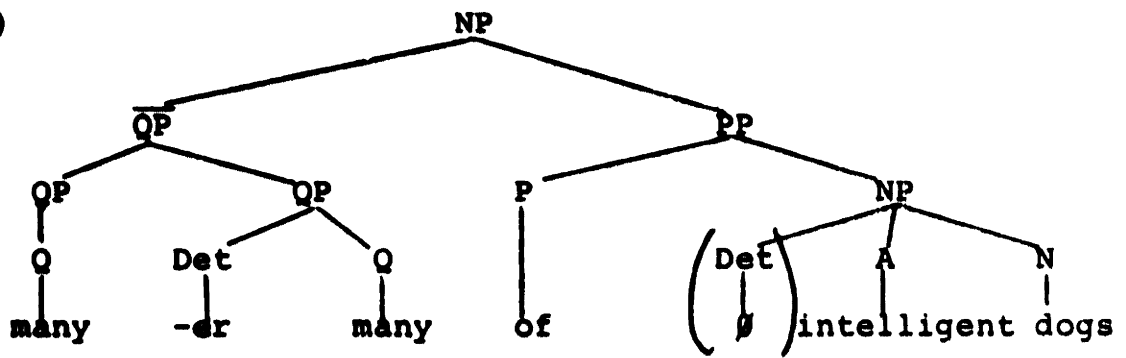

Though we have [(so) many more] and [(so) much more], we cannot have *[more more]; therefore (255) is unambiguous, deriving from the compared form of (252a), as shown in (256).

255) more more intelligent dogs

256)

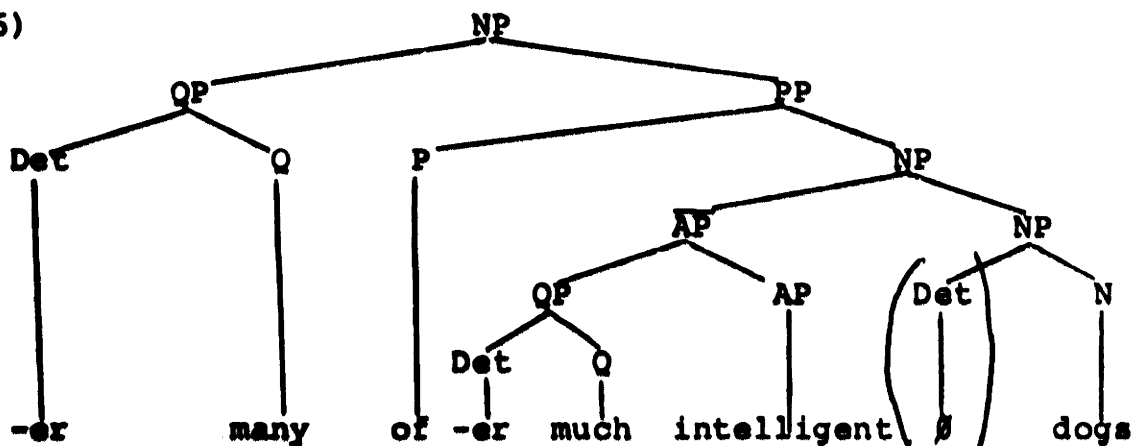

These are just a small sample of the many structural sources of the heads of comparatives. In the next section I turn to the clauses and the operations of Comparative Formation.

(ii) Comparative Formation

Our slow preparation has now cleared the way for a rapid advance into comparative clause structure. The syntax of the head, though complex, had to be analyzed in some detail before examining the processes of CF, those basic operations which affect the full comparative clause construction consisting of head and \bar{S} . The reason is simply that CF involves the deletion of some element in the clause which is "bound" by the head.

How can it be shown that deletion takes place? For those comparative clauses which retain a verb in surface structure, it is often easy to discover evidence of deletion. One trick is simply to find a rule which can only have applied in the presence of the missing element.

In (1), for example, there-insertion has displaced a subsequently deleted element:

- 1) More discoveries have been made in the last year alone than we thought there'd be ___ in the entire decade.

In (2), Subject Shift has applied to a now-missing subject:

- 2) More progress has been made than _____ seems to be possible.

If we assume that deletion takes place, then the normal operation of these transformations is sufficient to explain examples like (1) and (2); without deletion, special means would have to be invented to account for the facts.

There is a type of comparative clause which, at first sight, may look unaffected by deletion:

3) The door is longer than the table is wide.

4) Fluffer ate as many flies as Semine ate bees.

I claim that deletion has taken place in (3) and (4), and specifically, that it is a QP which has been deleted. The clauses of (3) and (4) have sources similar to (5) and (6), respectively:

5) than the table is [^xthat] much_{QP} wide.

6) as Semine ate [^xthat] many_{QP} bees.

(I leave open the exact nature of the determiner of the QP.)

Observe that Aux-contraction, which is generally inhibited in front of a deletion site (see Bresnan 1971a and the references cited there), is bad in (7) but good in (8):

7) *...than the table's wide.

8) ...and the table's wide.

What could differentiate (7) and (8) but the deletion of some element between the auxiliary and the adjective in (7)? The obvious candidate for the missing element is the QP

discussed in the preceding section. The underlying structures for (7) and (8) may be pictured in (9) and (10), respectively.

9)

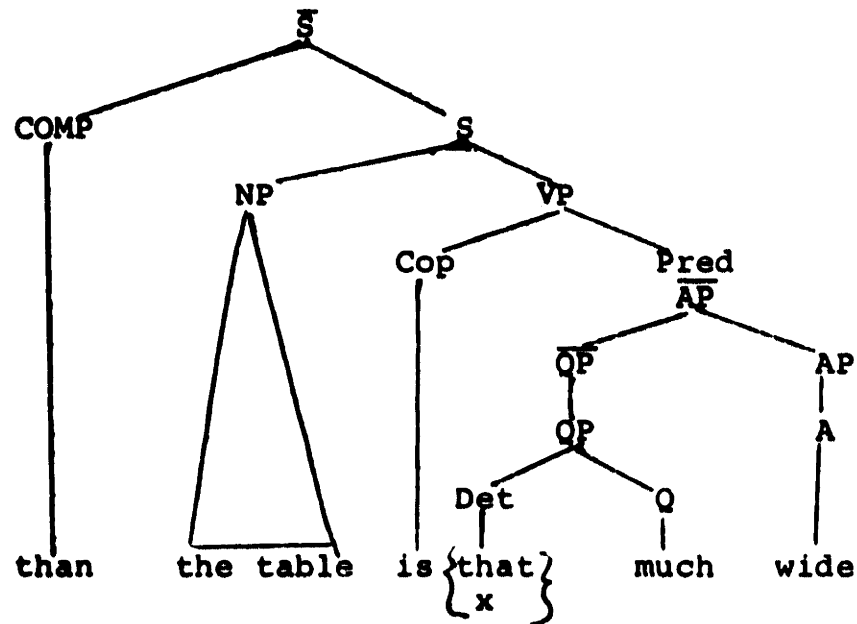

10)

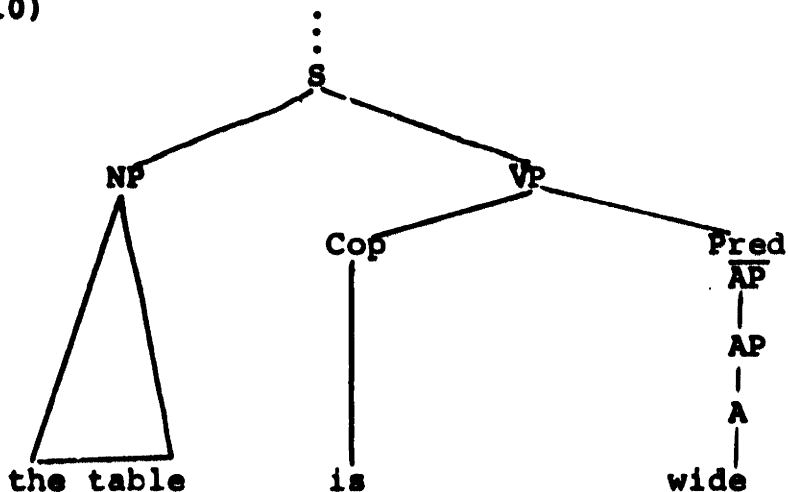

Corroboration for this representation of the underlying difference between (7) and (8) comes from a difference in meaning. While (8) implies that the table is positively wide, (7) does not. (7) suggests that the table's width is surpassed by the door's length, but there is no implica-

tion that "the table is wide": it may, in fact, be quite narrow.

The semantic difference between the plain AP and the AP modified by QP is brought out clearly in a case like (11):

- 11) All politicians are dishonest, but Grafter is even less honest than the rest of them.

(11) would be contradictory if the than clause derived from "the rest of them are honest"; instead, it must come from "the rest of them are x much honest", i.e. honest to an unspecified (possibly negative) degree, which serves as a reference point for comparing Grafter's honesty.

Here too, then, we find evidence that something is deleted from the comparative clause. It appears to be minimally a QP which undergoes deletion, and the deletion is obligatory: compare (4) to (12):

- 12) *Fluffer ate as many flies as Semine ate (that) many bees.

In addition to this minimal obligatory deletion of QP, the comparative clause may undergo more extensive deletions, which often leave nothing but a single phrase or word beside the COMP: as me, than 6, than ever, as to you, as yesterday, than either, than shy, than in (cf. He's more often out than in). Apparently, any constituent of a sentence can be left; even sequences of sentential constituents can occur, e.g.,

as her here on Tuesday from "I'm as willing to visit you there on Monday as her here on Tuesday". The very multiplicity of possible constituents indicates a clausal source for these truncated than and as phrases. If than and as are complementizers, then of course the truncated phrases must be the vestiges of \bar{S} .

Nevertheless, it might be thought that than and as are prepositions, at least in their occurrences in certain abbreviated phrases. The direct evidence for this view is extremely scanty. There are some noncomparative uses of as in which it may well be a preposition, as in (13):

13) As a small girl, she enjoyed sports.

Given the relation between the preposition for and the complementizer for (chapter 2), I do not wish to rule out the possibility of a similar relation between a prepositional as and a COMP as, although I have not investigated it. But the evidence for a prepositional than is even less compelling. Archaic-sounding examples like (14), where than moves along with its "object", have been taken to show that it is a preposition:

14) God is a being than which nothing greater can be conceived.

But such examples are far from natural in contemporary English:

15) *Boys than whom most girls are taller are unhappy.

16) *The kind of steak than which hamburger costs more

isn't very good.

Furthermore, as sounds considerably worse than (14) in a parallel sentence:

- 17) *God is a being as which nothing as great can be conceived.

The question of "case government" by comparative as and than is considered in Burt (1969).

Against the view just considered, there is some rather interesting evidence that the truncated than and as phrases are the vestiges of full clauses, as we would expect if than and as are complementizers. (I except such fixed expressions as other than [=except for, apart from] and as well as [=in addition to], which are probably not live comparatives.)

Consider the following facts:

- 18) a. John is more than 6 feet tall.
 b. *John is more than Bill tall.
 c. John is taller than six feet. (Also: taller than six feet tall)
 d. John is taller than Bill.
- 19) a. Mary has more than two friends.
 b. *Mary has more than just Bill and Pete friends.
 c. Mary has more friends than two.
 d. Mary has more friends than just Bill and Pete.

Observe that than six feet can occur either pre- or post-

adjectivally (18a, c), but than Bill must be placed to the right of the adjective (18b, d). Similar facts hold with respect to the compared nouns in (19). For as phrases we have (20) and (21):

- 20) a. They may grow as much as six feet high.
 b. *They may grow as much as bamboo high.
 c. They may grow as high as six feet.
 d. They may grow as high as bamboo.
- 21) a. Some of them made as many as 20 errors.
 b. *Some of them made as many as Joan errors.
 c. Some of them made as many errors as 20.
 d. Some of them made as many errors as Joan.

To explain the distribution of these kinds of than and as phrases, I assume, first, that they derive from full clauses; second, that an element is deleted from the clause; and third, that the remainder of the clause is lodged to the right of the constituent which governs the deletion (i.e., the head, to which the deleted element is "identical"). These assumptions are simply the basic principles of comparative formation, which I will now apply to the problem posed by (18)-(21).

First, I will justify the assumed constituent structure, namely (22), against a rival possibility, (23):

- 22) (more than six feet) tall
 (as much as six feet) high

- 23) ((more than six) feet) tall
 ((as much as six) feet) high

In (23), much would modify not the adjective, but feet; (23) thus has the immediate undesirable consequence of requiring *much feet rather than many feet (cf. that many feet high vs. *that much feet high). Thus from (23) we should expect *as many as six feet high. In (23), the than and as phrases excluded the measure constituent feet, so we might also expect *as many feet high as six and *more feet tall than six, instead of (20c) and (18c); and why should we not have *as many feet as six high, *more feet than six tall? Further, given that the truncated clause can be omitted (as in more (than enough) food), we would expect (23) to yield *more feet tall, *as much feet high, omitting than six. The correct analysis, (22), yields more tall (+ taller) and as much high (+ as high), as desired.

Next, I will consider the content of the hypothesized source-clauses for the than and as phrases in (18)-(19). (The analysis for (20) and (21) will then be obvious.)

Consider the following arrays:

- | | | |
|--------|---------------------------------------|-----------------------|
| 24) a. | Six feet = that much | QP = QP |
| b. | *Bill = that much | *NP = QP |
| c. | Six feet (tall) = that (much) tall | AP = AP or QP = AP |
| d. | Bill is that (much) tall | NP is AP |

- 25) a. two = that many QP = QP
 b. *just Bill and Pete = that *NP = QP
 many
 c. two friends = that many NP = NP
 friends
 d. just Bill and Pete = that NP = NP
 many friends

(24) and (25) embody the generalization that syntactic identities (indicated by '=' and distinguished from predication) can be formed only between elements of the same or similar categories. To illustrate, six feet and that much are both QP's, belonging to the category of scalar measurement; the same holds for two and that many, as count QP's. We can also equate six feet (tall) and that tall, as in the situation of (26):

- 26) John said he's six feet tall. How tall is that?
 Six feet (tall) is that tall. [pointing]

Recall from section (i) that QP and AP are often interchangeable. In contrast, Bill and just Bill and Pete are NP's and cannot be syntactically equated with measure categories (24b, 25b); they can, however, be equated with measurable NP's (25d) or linked with a predicative (24d).

I must comment on the odd notion of "syntactic identity", which I have slipped in above. I distinguish '=' from be in (24) and (25) on semantic grounds, but this distinction has a syntactic correlate:

- 27) *John is taller than six feet is.
- 28) John is taller than Pete is.
- 29) *Mary has more friends than two $\left\{ \begin{array}{l} \text{is} \\ \text{are} \end{array} \right\}$.
- 30) *Mary has more friends than just Bill and Pete $\left\{ \begin{array}{l} \text{is} \\ \text{are} \end{array} \right\}$.

Where I have used '=', a form of be cannot occur in the comparative phrases. One wonders if the be of identity [='] is inserted into identities by a late rule, following CF; but this is mere speculation.

I now take (24) and (25) as the contents of the underlying than-clauses in (18) and (19). It is possible that taller than six feet tall → taller than six feet by a deletion rule, which may be obligatory when the head adjective or noun is completely identical to the clause adjective or noun: cf. *as tall as six feet tall, and *more friends than two friends. Full repetition of tall and friends sounds worse to me than the partial repetition in taller than six feet tall.

Consider the derivation of (18a):

31) a.

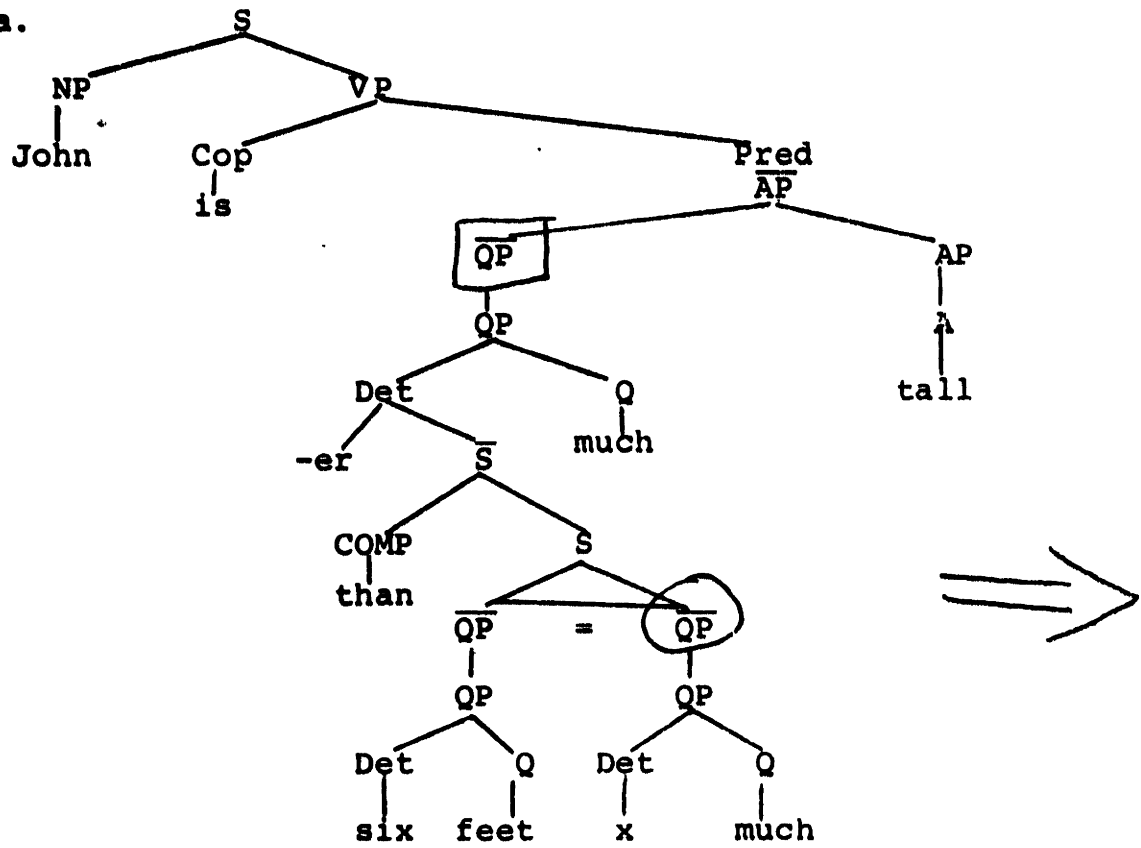

31) b.

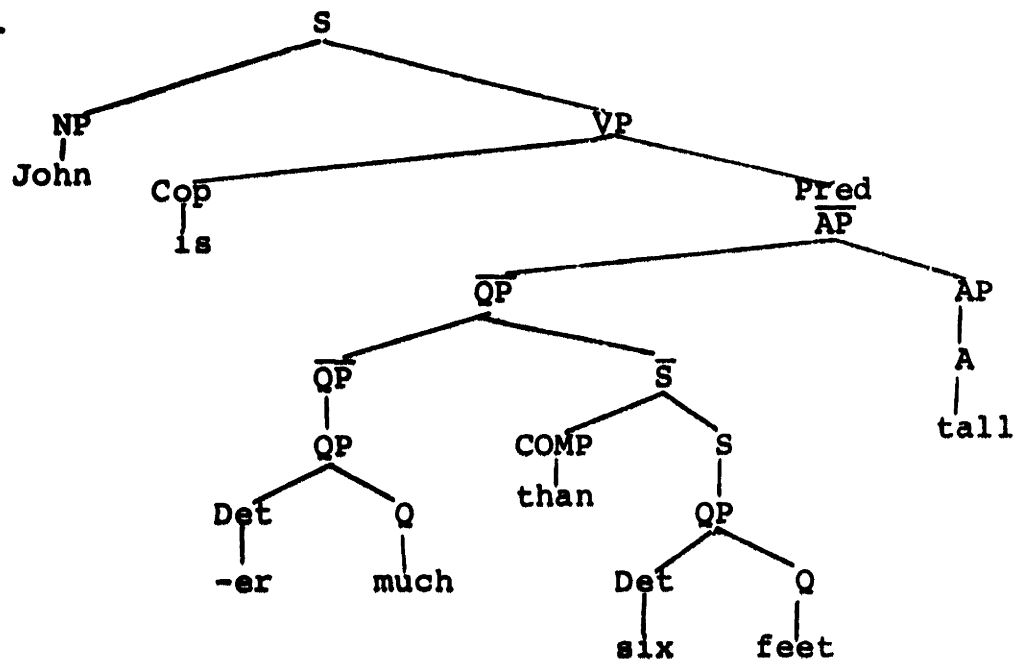

(31a) depicts the approximate deep structure of (18a).

Comparative Formation applies in $\boxed{\overline{QP}}$, deletes \overline{QP} , and extraposes \bar{S} around $\boxed{\overline{QP}}$, yielding (31b).

Compare to (31) the derivation of (18d):

32) a.

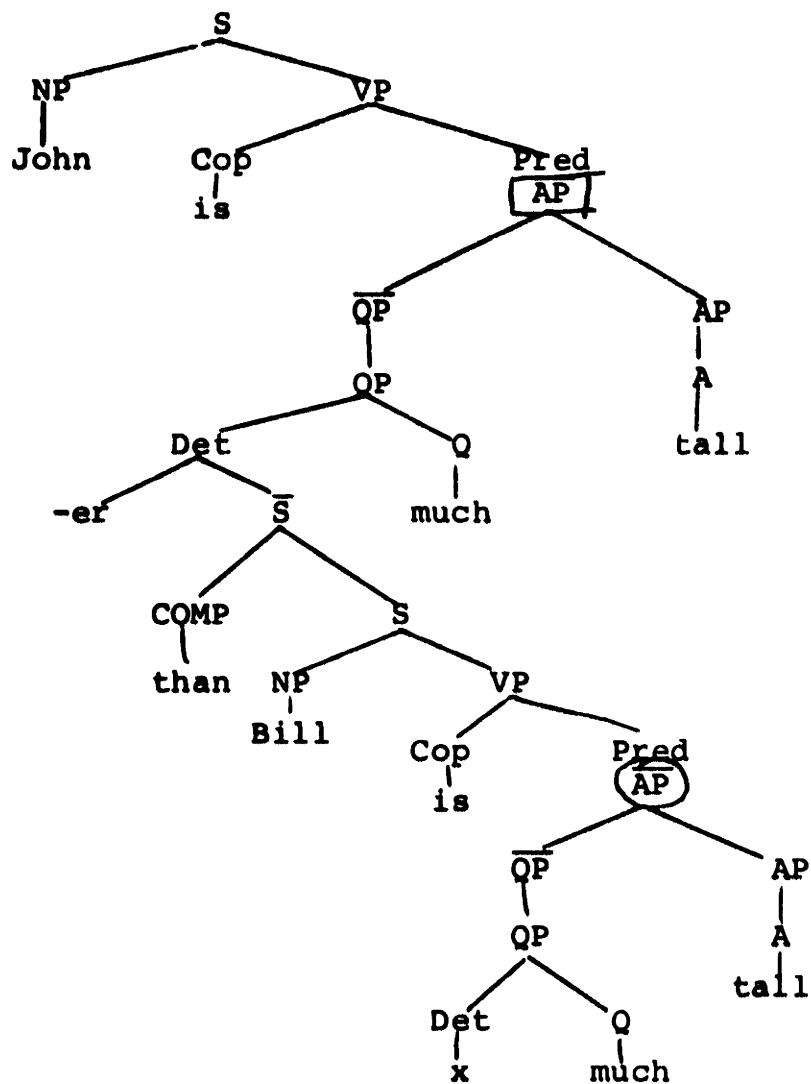

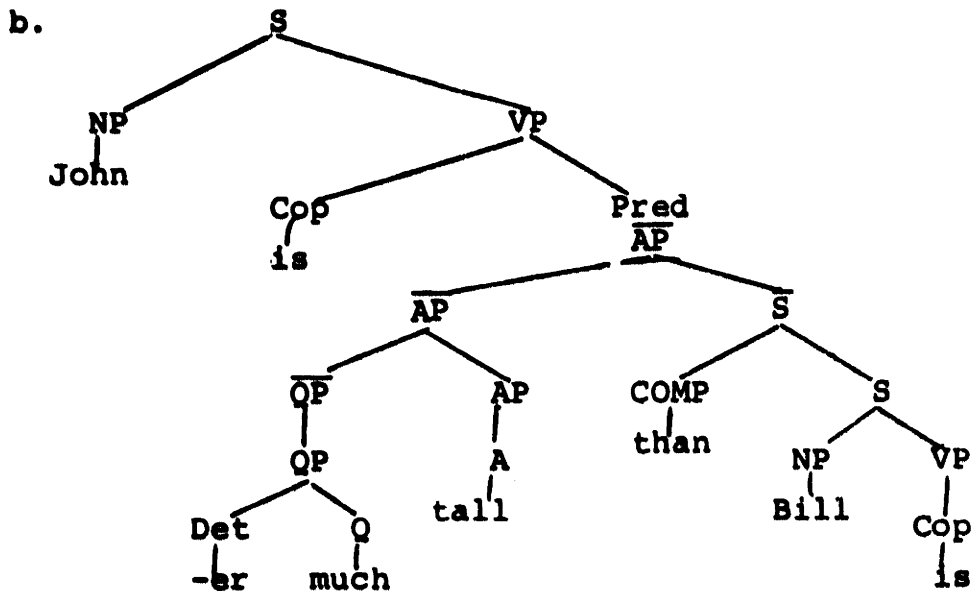

I ignore irrelevant transformational processes, such as the deletion of much on the \overline{AP} cycle. Comparative Formation applies in \overline{AP} , deletes \overline{AP} , and extraposes \overline{S} around \overline{AP} , to give (32b). On a later cycle, the dangling is may be optionally deleted.

Note that in (32a), what is deleted is the entire \overline{AP} , while in (31a), what is deleted is merely a \overline{QP} (namely, \overline{QP}). In other words, the head of the than-clause in (18a) is a subpart of \overline{AP} , namely a \overline{QP} , while the head of the than-clause in (18d) is the entire \overline{AP} . These derivations illustrate the third principle of Comparative Formation, that the clause is positioned to the right of its head.

Observe that (18b), *John is more than Bill tall, is ungrammatical because the underlying clause, (24b) *Bill = that much, is ill-formed. But (18c), John is taller than

six feet, is derived from the following source:

33)

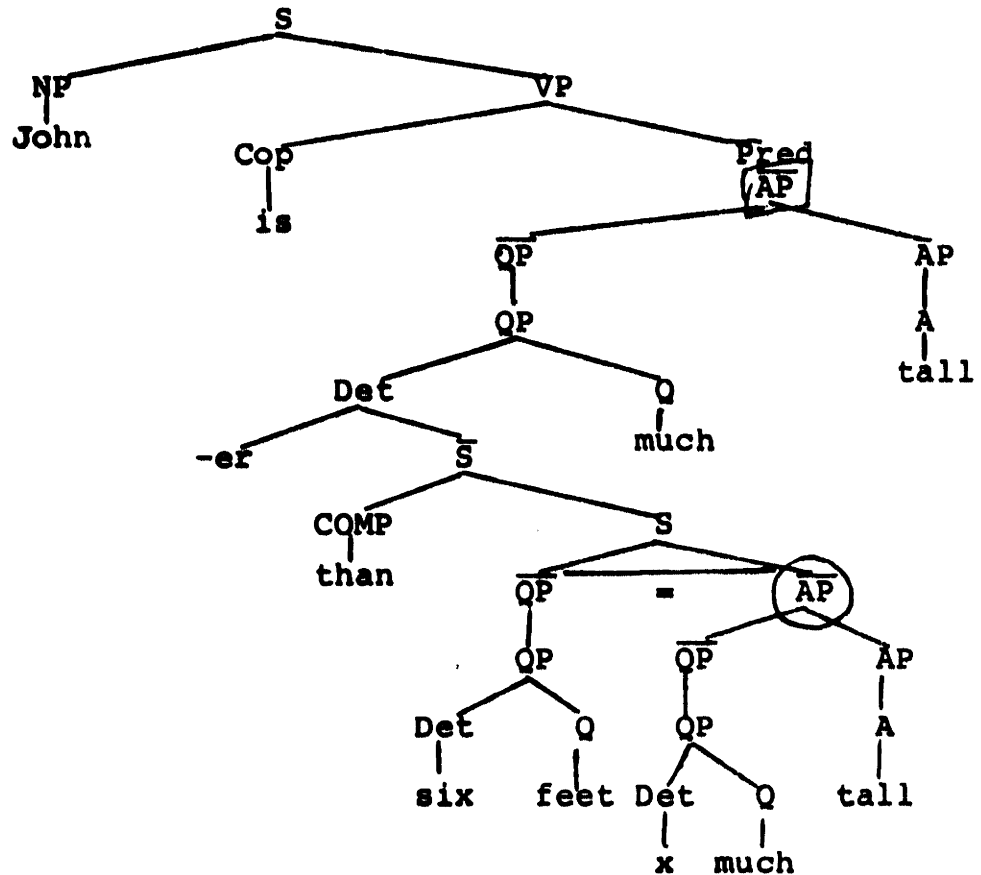

The head of the clause in (33) is AP. An alternative source for (18c) would have [six feet tall = x much tall] in the clause (see 24c).

Before going on, I will now answer several questions which may have occurred to the reader.

(I) One is, what accounts for the difference between (18a, c) and (34a, b)?

- 34) a. *John is more than five feet short.
 b. John is shorter than five feet.

((34) was brought to my attention by Roger Higgins.)

(34b) is certainly no problem: it can be derived from a source like (33), with the clause contents [five feet = x much short].

To understand the ungrammaticality of (34a), we must note that certain adjectives, including "privative" adjectives like short, do not admit modifiers of definite measurement: compare How tall is he?, five feet tall with *How short is he?, *five feet short. But these adjectives do permit comparison: He's less short than I thought, He's shorter than that.

Now let us examine the source that (34a) would have to have, according to our analysis:

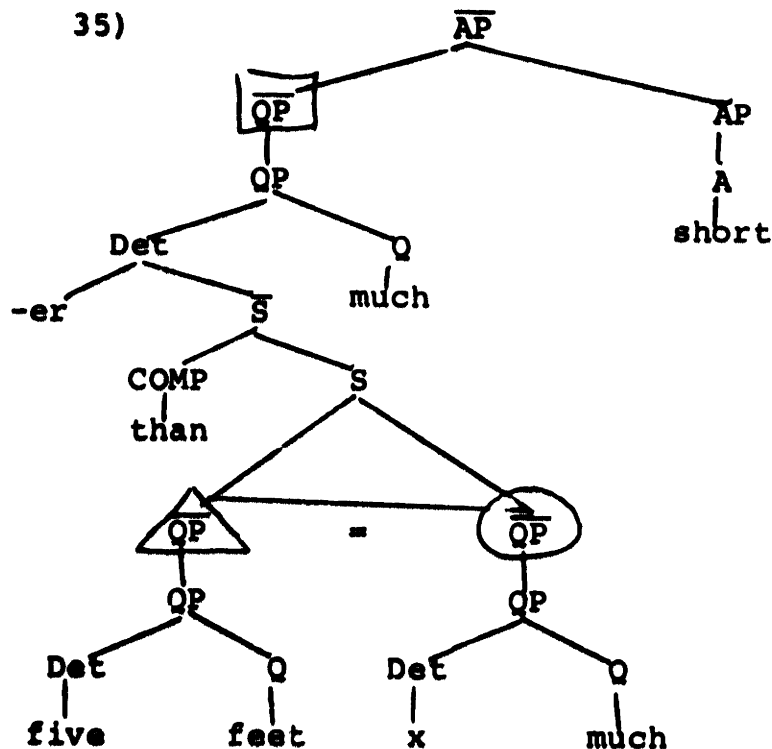

\overline{QP} must be deleted under "identity" to \overline{QP} -- that is, \overline{QP} must be featurally nondistinct from \overline{QP} ; but \overline{QP} is linked in an identity with \overline{QP} , which is a definite measure phrase.

Because \overline{QP} , as a modifier of short, cannot be a definite measurement, \overline{QP} cannot be definite. But \overline{QP} is equated in S with a definite measure phrase. This, I believe, is the source of (34a)'s ill-formedness.

Similar oddities (e.g., the difference between faster than 30 m.p.h. and *more than 30 m.p.h. fast) have a similar explanation under the analysis of comparatives I am proposing.

(II) A second question is, why is it that in derivations (32) and (33), Comparative Formation had to "wait" until the \overline{AP} cycle applied, while in (31) it applied on the \overline{QP} cycle contained in an \overline{AP} ? In other words, what prevents the derivation of nonsentences like *John is more than Bill (is) tall tall. through the application of Comparative Formation to the higher \overline{QP} rather than \overline{AP} ? (see (32a).)

In the particular cases (32) and (33), I omitted the \overline{AP} cycle, which would have deleted the much before the higher \overline{QP} -cycle could be reached. However, the question is still applicable to examples like (19) and (21): how do we

avoid *Mary has more than just Bill and Pete (are) friends friends?

The obvious answer is that Comparative Formation cannot delete a left-branch from an AP (a variant of Ross' left branch condition (Ross (1967))). But this account would require careful formulation, for we do have examples like (36):

36) Mary has more enemies than Bill has friends.
Deleted from (36) is an underlying \overline{QP} x many, which is a left branch of the NP x many friends. Note, however, that in (37), Comparative Formation still must apply on \boxed{NP} , rather than the left branch \overline{QP} , to avoid (38).

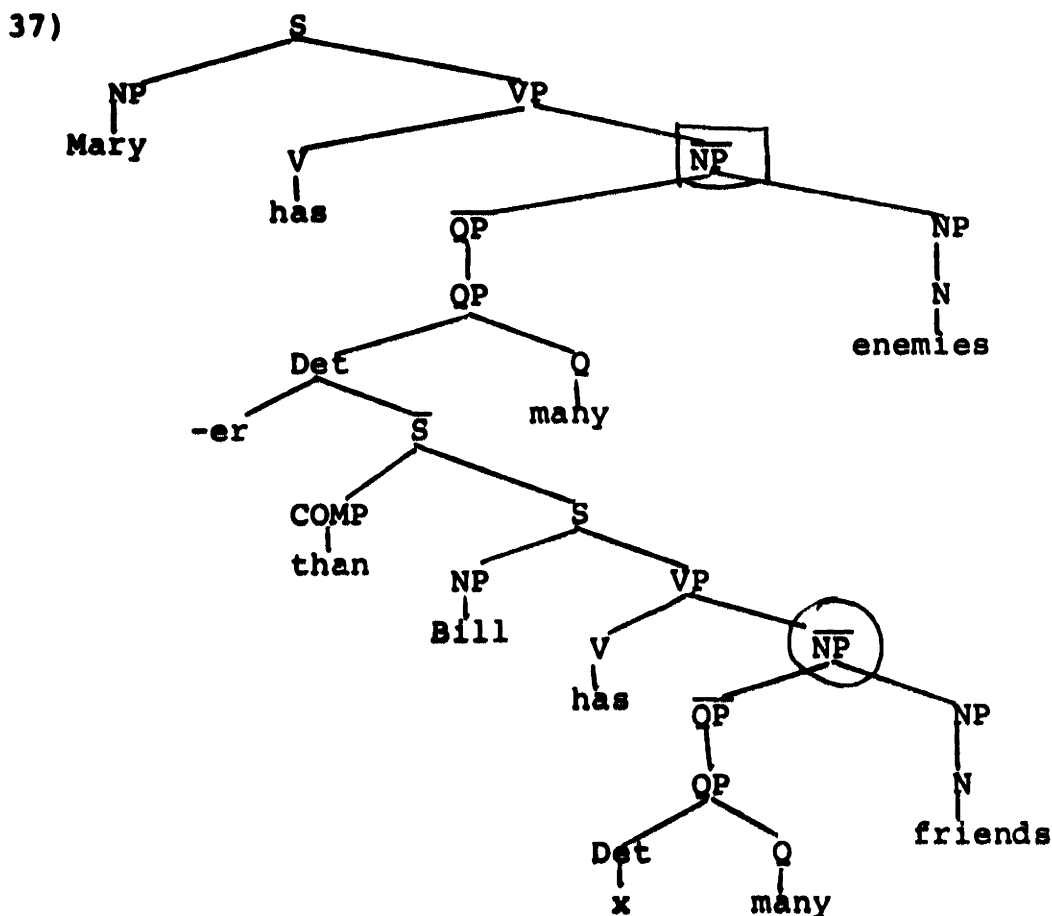

38) *Mary has more than Bill has friends enemies.

To solve this problem, we might take the following approach.

Ross' left-branch condition is a constraint on variables.

No variable (in the structural description of certain transformations) can "cover" everything up to a left branch; to put it differently, the left branch of an NP cannot be factored out by flanking variables. (39)

illustrates this forbidden situation:

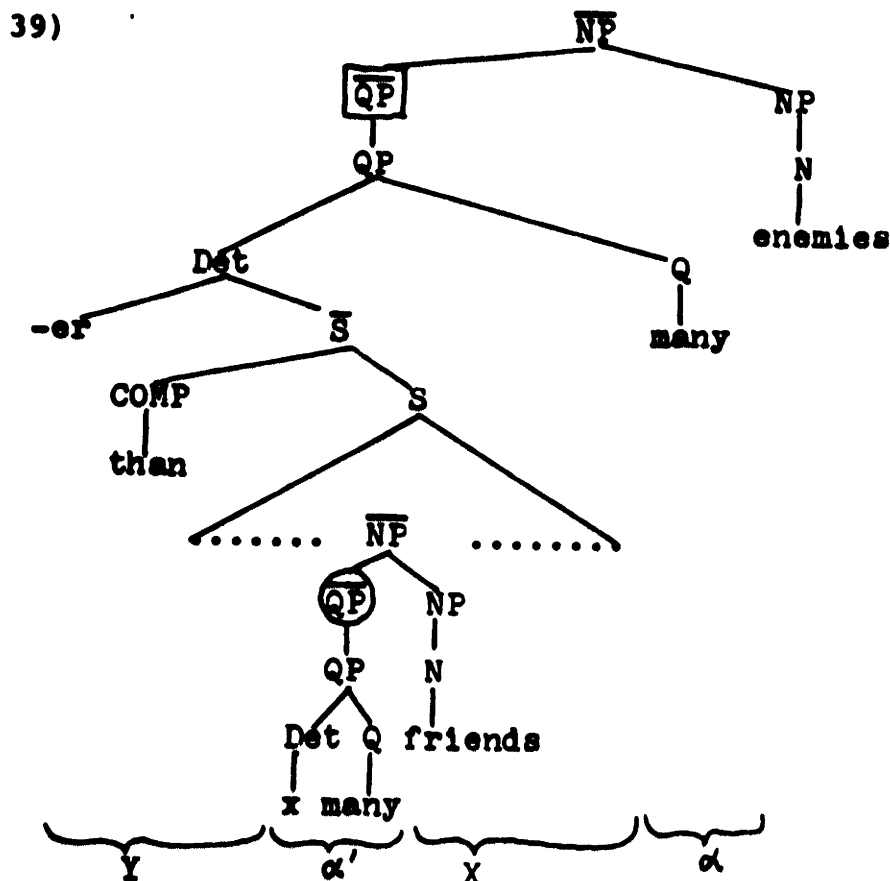

If α' were deleted under "identity" to (non-distinctness from) α , the right variable X would abut a left branch. Thus Comparative Formation could not apply to (39) in the \overline{QP} cycle, and (38) would not be derivable -- just as desired.

This approach still leaves the problem of deriving (36).

To see how (36) might be derived, look at (40).

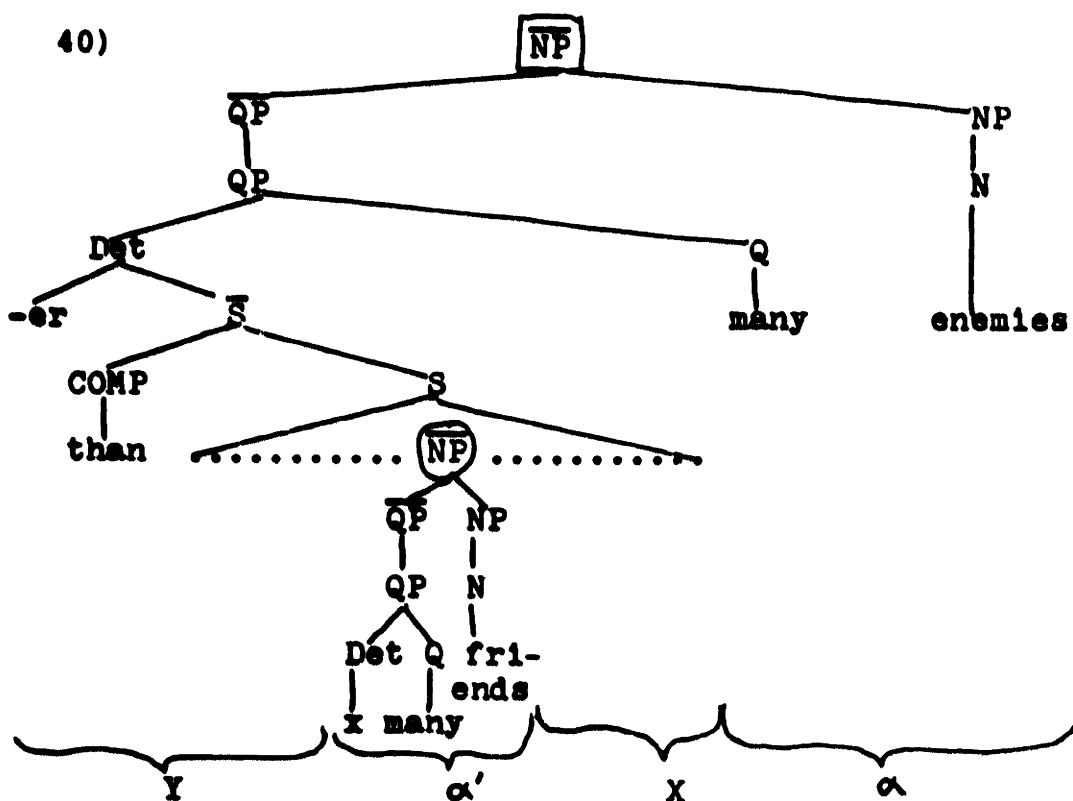

In (40), X no longer abuts a left-branch, but now α' is not identical to α . However, the subpart of α' which is identical to a subpart of α is deleted -- or, only as much is deleted as is "recoverable". Thus, the unspecified Det of Q, x, is deleted, together with everything that matches the head. This property of deleting only as much as is recoverable may reflect a general constraint on "variable-deletion" rules; Comparative Formation most probably involves the deletion of a "variable" category or sequence of categories, since it applies in the same way to QP, AP, NP. Further research must be done to determine whether this tentative solution is adequate.

(III) A third question to be answered is, why assume that the Comparative clause originates in the determiner?

This assumption may or may not be ultimately correct, but it has several practical advantages. It provides a distinct syntactic representation with which the unique grammatical function mentioned in the introduction to this chapter may be associated. Further, the cooccurrence between each clause and its governing determiner is easily stated on this assumption. Since the distance between the extraposed clause and its associated determiner can be extended at will, it would be hard to express the cooccurrence otherwise. For example, in (41), the surface structure distance between the Det element and its associated COMP can be increased arbitrarily.

- 41) a. Mary doesn't have as many too many to many...
 as Jane.
- b. Jane has more nearly as many too many... than
 Mary.

As a final point in reply to the question, it should be observed that what is deleted from a clause by Comparative Formation is invariably just that which matches the head, to the right of the Det associated with that clause. In (42), for example,

- 42) Mary swam five more laps than Joan swam.
 it is understood that Joan swam an unspecified number of

laps -- "x many laps" -- and that Mary swam five more than that number; the number five does not enter into the understood contents of the than-clause.

This fact is represented in (43):

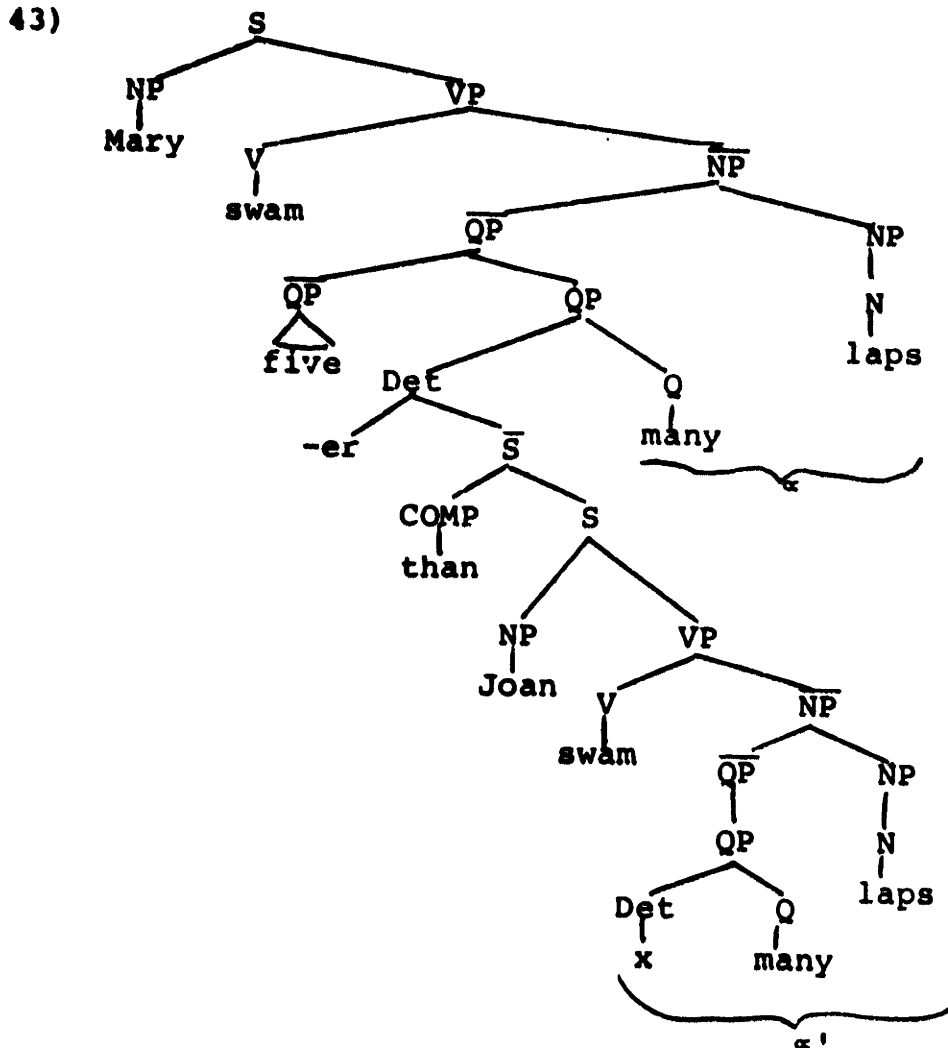

The deleted α' , which must be recoverable, includes an unspecified Det and a sequence of constituents, many laps, which matches α .

For a slightly more complicated example, consider (44) and

It is understood in (44) that Linda swam an unspecified number of laps more than Joan swam -- "x many more laps than Joan swam" -- and that Mary matched that number of laps. The understood content of the than-clause is thus β' in (45), which includes the recoverable Det together with a sequence which matches β . Excluded from the than-clause, however, is everything to the left of -er.

To summarize the analysis, the comparative clause originates with its governing Det in deep structure and undergoes an obligatory operation deleting everything recoverable from a constituent of the clause which matches the head. In the case of full clauses, it is easy to argue for deletion on the basis of syntactic and semantic evidence. In the case of truncated than and as phrases, their variable positioning within the comparative construction follows from our analysis, assuming that they, too, are derived from underlying full clauses.

This elementary account of the basic processes of Comparative Formation must be refined and elaborated. I have already indicated how the difference between examples like more than five feet tall and *more than five feet short can be explained (in (I)); how one technical problem of rule application might be solved (in (II)); and what the source of "stacked" comparatives such as as much more

than x as y is under this analysis. I have ignored many other important problems in this rich syntactic subsystem. For example, I have not touched on the relation between modifiers of \overline{QP} and the by-phrase (far too tall, *far as tall, too tall by far, *as tall by far). Nor have I discussed the differences between comparative clauses and other clause types associated with QP, AP, such as the resultative (so tall that S) and purposive (too tall/tall enough/sufficiently tall for S). As exhaustive account must await further research.

(iii) The Fixed Subject Constraint Revisited

At this final point I will quickly draw together a few loose threads and end rather speculatively.

I have not stated the Comparative Formation rule, but only discussed some of its properties. I observed in Chapter 3 that Comparative Formation is affected by the Fixed Subject Constraint. This fact is rather a puzzle, since Comparative Formation appears to be a deletion rule, while Equi-NP deletion -- another deletion rule -- is not subject to the F.S.C.; and in any event, the F.S.C. is supposed to prohibit certain movements.

I believe that in fact the F.S.C. applies not to movements, but to deletions -- specifically, to the deletion component

of movement rules. Any movement rule can be factored into two operations, a copying and a deletion. For example, 'XAB → AXB' can be written 'XAB → AXAB → AXØB'. There are several bits of evidence that the F.S.C. actually constrains deletions associated with movement rules.

First, in Relative Clause Formation, a copy pronoun can sometimes be left behind, when the relative pronoun has been moved to COMP:

- 1) The boy who_i the teacher said $\left\{ \begin{array}{l} he_i \\ \emptyset \end{array} \right\}$ was bad.

Now observe that when a that complementizer is left after said, the pronoun cannot be deleted:

- 2) The boy who_i the teacher said that $\left\{ \begin{array}{l} he_i \\ * \emptyset \end{array} \right\}$ was bad.

In other words, in the process of Relative Clause Formation, who can be "moved" over the COMP from a fixed subject position, but he_i cannot be deleted from that position. (This argument was suggested to me by Emily Pope.)

Second, there is a curious phenomenon of secondary deletion associated with Question Formation and comparatives.

Compare (3) and (4):

- 3) You like someone_i more than Mary likes $\left\{ \begin{array}{l} him_i \\ * \emptyset \end{array} \right\}$.
- 4) Who_i do you like _____ more than Mary likes $\left\{ \begin{array}{l} *him_i \\ \emptyset \end{array} \right\}$?

When the question word is moved in (4), its coreferent pronoun must be deleted. But now observe what happens when the coreferent pronoun occupies a fixed subject position, next to the complementizer than:

5) Someone_i likes you more than $\left\{ \begin{smallmatrix} \text{he} \\ * \emptyset \end{smallmatrix} \right\} \text{ }_i$ likes Mary.

6) Who_i likes you more than $\left\{ \begin{smallmatrix} \text{he} \\ * \emptyset \end{smallmatrix} \right\} \text{ }_i$ likes Mary?

In fixed subject position, the deletion associated with Question Formation cannot occur.

Thus we must revise the F.S.C. to apply to deletions associated with movement rules rather than "movements" per se. Is there any evidence that Comparative Formation could be regarded as a "movement rule"? Recall the dialectal than what..., as what... comparatives mentioned in the introduction to this chapter. If we assume that the what is a pro-form attracted to the complementizer from its underlying point, we can regard Comparative Formation as a process which both copies and deletes elements, and hence as a movement rule.

Then Comparative Formation and Relative Clause Formation could be collapsed into the same rule (or rule type), applying to isomorphic structures: this rule (or rule type) would involve both a copying operation ("attraction to COMP") and a deletion, although if there were no suitable pro-form to be copied, only the deletion would take place.

As a final revision to the F.S.C., we must note that it prohibits not only certain deletions of subjects, but certain deletion of parts of subjects:

7) More beans were eaten than I thought $\left\{ \begin{array}{c} *that \\ \emptyset \end{array} \right\}$ peas were.

In (7), it is the QP modifying peas which has been deleted by Comparative Formation, and this deletion is prevented by an adjacent COMP.

Thus, the F.S.C. should be revised roughly as follows:

8) F.S.C. (revised version)

No movement rule T may delete a (part of a) subject if it lies next to a complementizer not mentioned in the structural description of T.

FOOTNOTES

CHAPTER 5

Section A

1. Cf. Greenberg (1962), universals 22, 24.

Section B

1. See, for example, Selkirk (1970), from which paradigms 51 and 52 are taken.
2. Those members of paradigms 4, 5 which signify paucity have special properties which deserve further investigation. For example, we have as much more intelligent but ?as little more intelligent, as many more people, ?as few more people. However, we have a little more intelligent, a few more people. Further we have few enough, little enough, but not *much enough, *many enough.
3. There exists an adjective which is, in some sense, intrinsically comparative, namely different. In some dialects, this adjective can take a than-clause: John is different than I thought. But even in those dialects in which different prohibits a than-clause, it still shares properties with compared, rather than simple, adjectives:

not any different not any taller *not any tall

so much different so much taller *so much tall

The interesting aspect of different is that much deletion (rule 10) is optional:

A tangerine isn't as much different from an orange as I'd thought.

A tangerine isn't as different from an orange as I'd thought.

Another adjective with similar properties is alike:

You and I are as much alike as a horse and a cow.

You and I are as alike as a horse and a cow.

Both adjectives permit little as well as less as modifiers:

This year's model is little different from last year's.

You and I are as little alike as a horse and a cow.

These two exceptional adjectives, by permitting optional rather than obligatory much deletion, provide some evidence for the analysis to be given, in particular for the existence of rule 10.

4. Additional evidence for (b) may be found in Selkirk (1970), although she ultimately rejects (b).
5. The simple comparative formation rules apply only within an AP. The difference between (a) John is angrier than he is sad and (b) John is more angry than sad [=John is angry, more than sad] shows this. In (b), more is not a constituent of the AP dominating angry, but a modifier of the VP;

thus we do not get *John is angrier than sad. The derivation of sentences like (a) is illustrated in section (ii) for The door is longer than the table is wide. Note that (a) allows that John may be both angry and sad; (b) suggests that John is angry rather than sad, or that it is more true to say of him that he is angry than that he is sad. Thus (as Larry Horn has pointed out to me), if we choose incompatible adjectives for comparison, we should find form (a) anomalous and form (b) acceptable, and this seems to be the case: cf. #I would say that John is taller than he is short and I would say that John is more tall than short.

6. These words may just as well be only parts of NP's, e.g., more of something, enough of something. Then their NP-like behavior would be attributable to the larger NP construction containing them rather than to their own label. Note that they can passivize: More was brought up at the meeting than we had time for; Enough has been said to convince me.
7. More and enough are not permutable in front of verb or subject, as many adverbs are. Their behavior is much closer to adverbs like quite a bit, a lot, than to often:

Sally { *quite a bit
*a lot
*enough
*more
often } eats caviar.

| | |
|---|--------------------|
| { <ul style="list-style-type: none"> *Quite a bit *A lot *Enough *More Often } | Sally eats caviar. |
|---|--------------------|

The more in the following sentences is also adverbial, and because it precedes an adverb or adjective we may speak of it as the post-object, pre-predicate adverb:

I did it more in jest than in anger.

Jack is more tall than thin.

8. The nonambiguity of (40), (41) follows from the deletion transformation of section (ii). The deleted element must be identical to (featurally non-distinct from) the head. After reading this chapter, the reader should be able to account for the difference between

*Jack eats more caviar than he sleeps.

Jack eats caviar more than he sleeps.

9. Alternatively, we may have an of-deletion rule, which removes an underlying of between Q and N.
10. I have not considered what explains the difference between
- *taller a man
- and examples like (115a). Note, however: no taller a man, *a no taller man.
11. The difference between "adjectival" adverbs and the

intensive members of Adv may show up in examples like the following:

That's stupid -- obviously so.
 *utterly so.
 *perfectly so.
 *really so.

12. I cannot explain why adverbs modifying adjectives cannot themselves be modified by enough while they can in isolation:

She writes legibly enough.

?It's a legibly enough written letter.

The ungrammaticality of *so much clear enough may be selectional: *much enough.

13. Note that the deletion of much in (189) and (190) is not accomplished by the much deletion rule already given (10). Much can be deleted after so only under special conditions:

I love her so much → I love her so.

I gave her so much ≠ *I gave her so.

I love her $\left\{ \begin{array}{l} \text{that} \\ \text{too} \\ \text{as} \end{array} \right\}$ much ≠ *I love her $\left\{ \begin{array}{l} \text{that} \\ \text{too} \\ \text{as} \end{array} \right\}$.

so much too much ≠ *so too much → *such too much

14. I have not attempted to analyze independent occurrences of such, as in such that..., such as to..., such as..... However, the following paradigms suggest a relation with

so:

A problem {such as to deceive even the best doctors.
such that no one could understand it.
such as could deceive even the best doctors.}

A problem {so difficult as to deceive even the best doctors.
so difficult that no one could understand it.
*so difficult as could deceive even the best
doctors.}

Cf. -- so difficult a one as could deceive even the best
doctors. .

15. The impossibility of *too tall men, *too good food, and
the like, is unexplained. It may have to do with an
output condition on Det A N sequences such that given
Det A N, the Det must be a nominal rather than adjectival
determiner. Then good enough food and such good food
would not be filtered out, because neither is any longer
of form Det A N.

LIST OF REFERENCES

- Aijmer, K. (1972). Some Aspects of Psychological Predicates in English. Stockholm Studies in English XXIV. Almqvist and Wiksell, Stockholm.
- Akmajian, A. (1968). "An Interpretive Principle for Certain Anaphoric Expressions." MIT ditto.
- Andrews, A. (1972). "A Typological Survey of Relative Clauses." MIT MS.
- Annear, S. (1967). "Relative Clauses and Conjunctions." PEGS.
- Anscombe, G.E.M. (1965). "The Intentionality of Sensation" in Analytical Philosophy 2nd series (ed. Butler).
- _____ (1967). "The Grammar of 'enjoy'." Journal of Philosophy 64, no.19.
- Bach, E. (1968). "Nouns and Noun Phrases," in Universals in Linguistic Theory (ed. Bach and Harms). Holt, Rinehart and Winston.
- Baker, C.L. (1968). Indirect Questions in English. Indiana University Ph.D. dissertation.
- _____ (1969). "Notes on the Description of English Questions: the Role of an Abstract Question Morpheme." Foundations of Language 6.

- Bolinger, D. (1968). "Entailment and the Meaning of Structures." Glossa 2, no. 2.
- Bowers, J. (1970). "Adjectives and Adverbs in English." reproduced by the Indiana University Linguistics Club.
- Bresnan, J. (1971). "A Note on the Notion 'Identity-of-Sense Anaphora'." Linguistic Inquiry II, no. 4.
- _____ (1971a). "Contraction and the Transformational Cycle in English." MIT ditto.
- _____ (1971b). "Sentence Stress and Syntactic Transformations." Language 46, no. 2.
- Burt, M.K. (1969). "Some Rules of Non-Constituent Deletion." MIT ditto.
- Chomsky, N. (1957). Syntactic Structures. Mouton, The Hague.
- _____ (1964). Current Issues in Linguistic Theory. Mouton, The Hague.
- _____ (1965). Aspects of the Theory of Syntax. MIT Press, Cambridge, Mass.
- _____ (1971). "Deep Structure, Surface Structure, and Semantic Interpretation" in Semantics: an Interdisciplinary Reader (ed. Steinberg and Jakobovits) Cambridge University Press.
- _____ (1971a) "Conditions on Transformations." reproduced by the Indiana University Linguistics Club.

- _____ (1971b). "Remarks on Nominalization" in Readings in English Transformational Grammar (ed. Jacobs and Rosenbaum). Ginn and Co.
- Dougherty, R. (1968). A Transformational Grammar of Coordinate Conjoined Structures. MIT Ph.D. dissertation.
- Emonds, J. (1970). Root and Structure Preserving Transformations. MIT Ph.D. dissertation. reproduced by the Indiana University Linguistics Club.
- Faraci, R. (1971). "A Preliminary Examination of for-to Purpose Clauses in English." MIT ditto.
- Gane, G. (1969). "On if and whether." MIT MS.
- Greenberg, J. (1962). "Some Universals of Grammar with Particular Reference to the Ordering of Meaningful Elements" in Universals of Language, 2nd ed, MIT Press, Cambridge, Mass.
- Hale, A. (1970). "Conditions on English Comparative Clause Pairings" in Readings in English Transformational Grammar (ed. Jacobs and Rosenbaum). Ginn and Co.
- Hasegawa, K. (1968). "The Passive Construction in English." Language 44.
- _____ (1969). "An Aspect of English Question Formation." Harvard MS.
- _____ (1972). "Transformations and Semantic Interpretation" Linguistic Inquiry III, no. 2.

- Helke, M. (1969). "On Reflexives in English." MIT MS.
- Heny, F. (1971). "Bantu Lexical Classes and Semantic Universals." University of Massachusetts ditto. for submission to Studies in African Linguistics.
- Hudson, R.A. (1972). "Why It Is that that that that Follows the Subject is Impossible." Linguistic Inquiry III, no. 1.
- Jespersen, O. (1969) Analytic Syntax. Holt, Rinehart and Winston.
- _____ (1927). A Modern English Grammar. 7 vols. George Allen and Unwin, London.
- Kajita, M. (1967). A Generative-Transformational Study of Semi-Auxiliaries in Present-Day American English. Sanseido, Tokyo.
- Katz, J. and P. Postal (1964). An Integrated Theory of Linguistic Descriptions. MIT Press, Cambridge, Mass.
- Kayne, R.S. (1969). The Transformational Cycle in French Syntax. MIT Ph.D. dissertation.
- _____ (1969a). "On the Inappropriateness of Rule Features." QPR RLE, MIT, no. 95.
- Kaufman, E. (1972). "Navajo Spatial Enclitics." MIT MS.
- Kean, M.L. (1972). "Strict Cyclicity in Phonology." MIT ditto.
- Kiparsky, R.P.V. and C. Kiparsky (1970). "Fact" in Progress in Linguistics (ed. Bierwisch and Heidolph), Mouton, The Hague.

- Klima, E. (1964). "Relatedness Between Grammatical Systems." Language 40.
- Lakoff, G. (1970). "On Generative Semantics" in Semantics: An Interdisciplinary Reader (ed. Steinberg and Jakobovits). Cambridge University Press.
- _____ (1971). Irregularity in Syntax. Holt, Rinehart and Winston.
- Lakoff, G. and S. Peters (1966). "Phrasal Conjunction and Symmetric Predicates" in Report NSF-17, The Computation Laboratory, Harvard University.
- Lakoff, R. (1968). Abstract Syntax and Latin Complement-ation. MIT Press. Cambridge, Mass.
- Langendoen, D.T. (1971). Essentials of Grammar. Holt, Rinehart, and Winston.
- McCawley, J.D. (1970). "English as a VSO Language." Language 46.
- _____ (1971). "Where Do Noun Phrases Come From?" in Semantics: an Interdisciplinary Reader (ed. Steinberg and Jakobovits). Cambridge University Press.
- Perlmutter, D. (1970). "On the Article in English" in Progress in Linguistics (ed. Bierwisch and Heidolph) Mouton, The Hague.
- _____ (1970b). "The Two Verbs Begin" in Readings in English Transformational Grammar (ed. Jacobs and Rosenbaum). Ginn and Co.

- _____ (1971). Deep and Surface Structure Constraints in Syntax. Holt, Rinehart, and Winston.
- Rosenbaum, P. (1967). The Grammar of English Predicate Complement Constructions. MIT Press, Cambridge, Mass.
- Ross, J.R. (1967). Constraints on Variables in Syntax. MIT Ph.D. dissertation. reproduced by the Indiana University Linguistics Club.
- _____ (1968). "On Declarative Sentences" in Readings in English Transformational Grammar (ed. Jacobs and Rosenbaum). Ginn and Co.
- _____ (1969). "Guess Who?" in Papers from the 5th Regional Meeting CLS, University of Chicago.
- _____ (1971). "Auxiliaries as Main Verbs" in Philosophical Linguistics, series 1 (ed. Todd). Great Expectations.
- Ross, J.R. and D. Perlmutter (1970). "A Non-Source for Comparatives." Linguistic Inquiry I, no.1.
- Sapir, E. (1921). Language. (Harvest Books edition)
- Selkirk, E. (1970). "On the Determiner Systems of Noun Phrases and Adjective Phrases." MIT ditto.
- Vago, R. (1972). "On the Universality of Subject Pronoun Deletion." Harvard MS.
- Zandvoort, R.W. (1969). A Handbook of English Grammar, 5th edition. Longmans.

BIOGRAPHICAL NOTE

The author was born on August 22, 1945. She attended elementary and secondary schools in California and received her college education at Reed College in Portland, Oregon, between 1963 and 1966. From 1967 to 1972 she was a graduate student at the Massachusetts Institute of Technology, first in philosophy and then in linguistics. She has published several articles in linguistics, is an associate editor of Linguistic Inquiry, and will become an Assistant Professor of Linguistics and Philosophy at Stanford University in Stanford, California, in the fall of 1972.